



Do 215B-5

Германский ночной истребитель II MB

В начале 30-х годов в мире возникла идея создания скоростного бомбардировщика, который мог бы обогнать современные ему истребители-бипланы. Одним из воплощений этой концепции стал двухмоторный бомбардировщик, разработанный германской фирмой Дорнье Флюгцугверке.

С начала 1940 г. началось производство небольшой серии из 105 самолетов Do 215B, на которых были установлены двигатели жидкостного охлаждения DB 601A.

В 1941 г. начался выпуск ночных истребителей Do 215B-5. На этих самолетах с мощным вооружением были установлены радары FuG 202 Lichtenstein. Do 215B-5 служили в ночной истребительной группе II/NJG 1 до начала 1944 г.

Тактико-технические характеристики Do 215B-5

Длина, м	16,54
Размах крыла, м	18,0
Взлетный вес, кг	8600
Двигатель	2xDB 601A, 1175 л.с.
Максимальная скорость, км/ч	465
Потолок, м	9000
Дальность, км	1805
Вооружение	1x20-мм пушка MG 151, 4x7,92-мм пулемета MG 17, 1x7,92-мм пулемет MG 15

ВНИМАНИЕ!

Перед сборкой внимательно прочитать руководство по монтажу. Каждая деталь пронумерована. Соблюдать последовательность монтажа. Необходимые рабочие инструменты: нож и напильник для зачистки деталей; резиновая лента, клейкая лента и зажимы для сушки белья для прижимания склеиваемых деталей. Детали из пластика очистить в растворе мягкого моющего средства и высушить на воздухе для того, чтобы краска и переводные картинки лучше прилипали. Перед приклеиванием проверить, подходят ли детали; клей наносить экономно. Хром и краску удалить с поверхностей склеивания. Небольшие детали покрасить перед тем, как они будут удалены из рамок. Краску необходимо хорошо просушить, только после этого продолжать сборку. Каждую соответствующую переводную картинку отдельно вырезать и примерно на 20 секунд окунуть в теплую воду. На обозначенном месте картинку отделить от бумаги и прижать промокающей бумагой.

ИСПОЛЬЗУЕМЫЕ КРАСКИ / USED COLORS:

	Revell	Tamiya		
A	108	XF1	Черный, матовый	Flat Black
B	105	XF2	Белый, матовый	Flat White
C	167	XF51	Темный серо-зеленый, мат.	Dunkelgrau RLM 74
D	140	XF27	Черно-зеленый RLM 70	Schwarzgrun RLM70
E	179	XF25	Серо-голубой, матовый	Mittelgrau RLM 75
F	149	XF19	Светлый серо-голубой, мат.	Hellblau RLM 76

Do 215B-5

WWII German Night Fighter

In the beginning of 30s there was appeared in the world an idea of high-speed bomber that could outstrip contemporary fighters. One of the objectifications of this conception became the twin-engine bomber designed by a German Dornier Flugzeugwerke company.

Since the beginning of 1940 it was produced small series of 105 Do 215B planes with liquid-cooled DB 601A engines. In 1941 it began production of Do 215B-5 night fighter modification. FuG 202 Lichtenstein radars were installed in these planes with powerful armament. They served in the night fighter unit II/NJG 1 up to the beginning of 1944.

Tactical and Technical Specifications of Do 215B-5

Length, m	16,54
Span, m	18,0
Start Weight, kg	8600
Engine	2xDB 601A, 1175 hp.
Max. Speed, km/h	465
Service ceiling, m	9000
Range, km	1800
Armament..	1x20-mm MG 151, 4x7,92 mm MG 17, 1x7,92 mm MG 15

CAUTION!

Read the instructions thoroughly prior to assembly. Each component is numbered. Adhere to specified sequence of assembly. Tools required: knife and file for removal of components from frame; rubber bond, adhesive tape and clothes pegs for clamping components together after applying adhesive. Clean plastic components in a mild detergent solution and allow to air-dry so that paint and transfers adhere better. Prior to applying adhesive, check to see whether the components fit together; apply adhesive sparingly. Remove chrome and paint from the contact surfaces. Paint small components before removing them from the frame. Allow paint to dry well, and only then continue to assemble. Cut out each transfer individually and immerse in warm water for approx. 20 seconds. Slide transfer off paper and into designated position, then press on with blotting paper.

01 СТАДИЯ СБОРКИ
ASSEMBLY STEP

03 СБОРОЧНАЯ ЕДИНИЦА
ASSEMBLY UNIT

x2 СДЕЛАТЬ ДВЕ ДЕТАЛИ
MAKE 2 PCS

■ ПРИ СБОРКЕ НЕ ИСПОЛЬЗУЕТСЯ
PARTS NOT FOR USE

A ИСПОЛЬЗУЕМАЯ КРАСКА
USED COLOR

***** СДЕЛАТЬ САМОМУ
SCRATCH BUILD

? ПРОИЗВОЛЬНЫЙ ВЫБОР
OPTIONAL

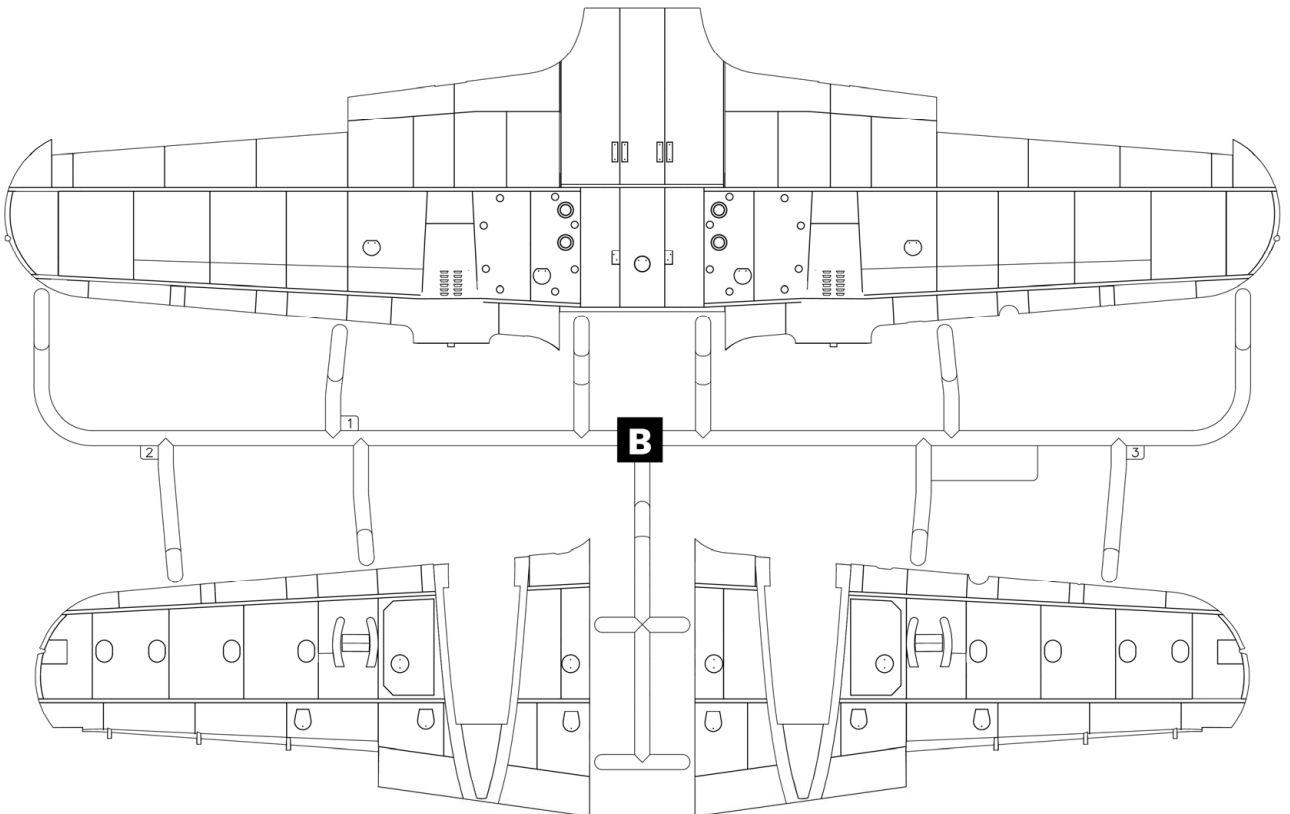
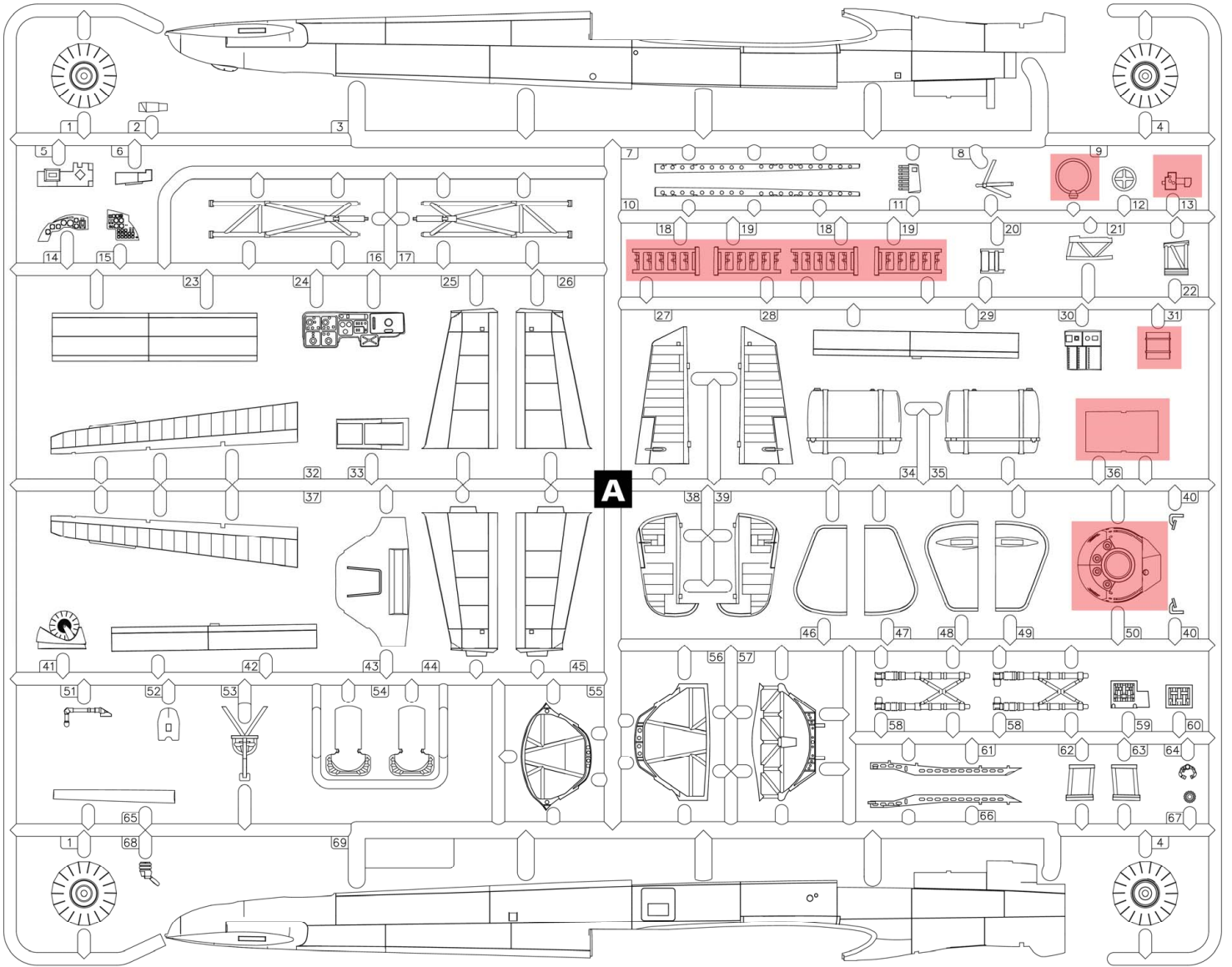

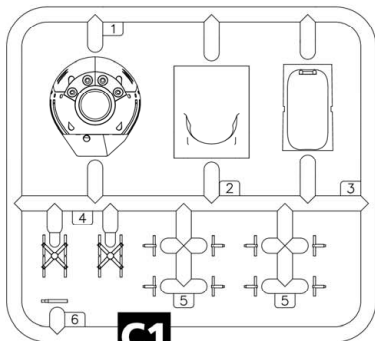
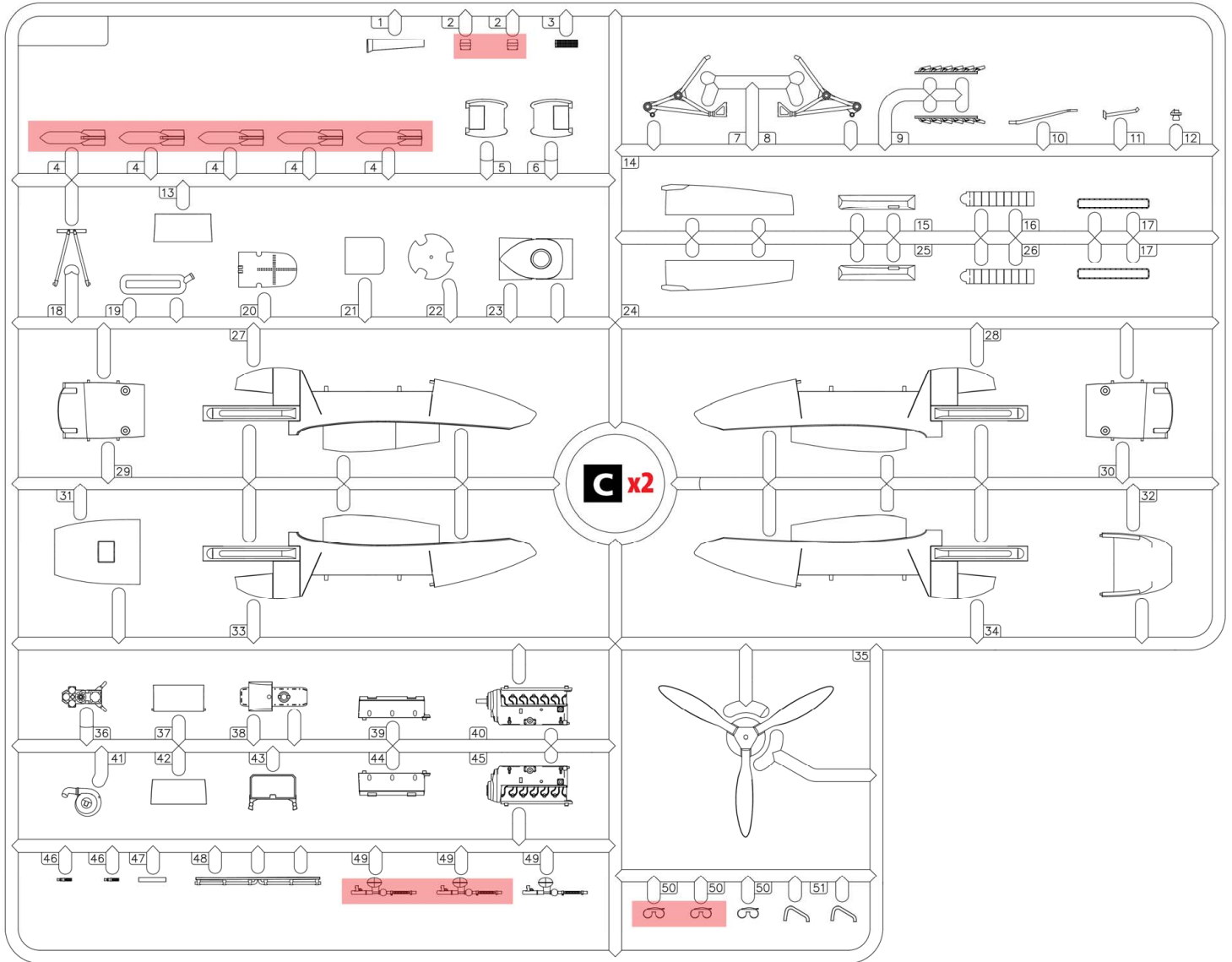

C1
x2

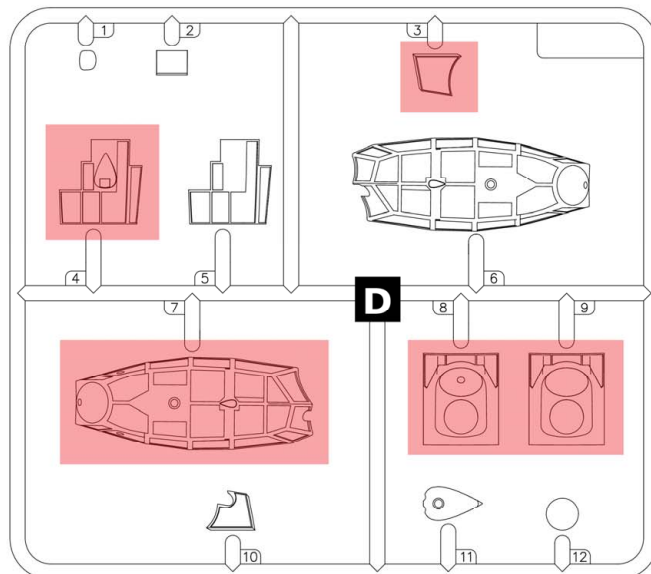

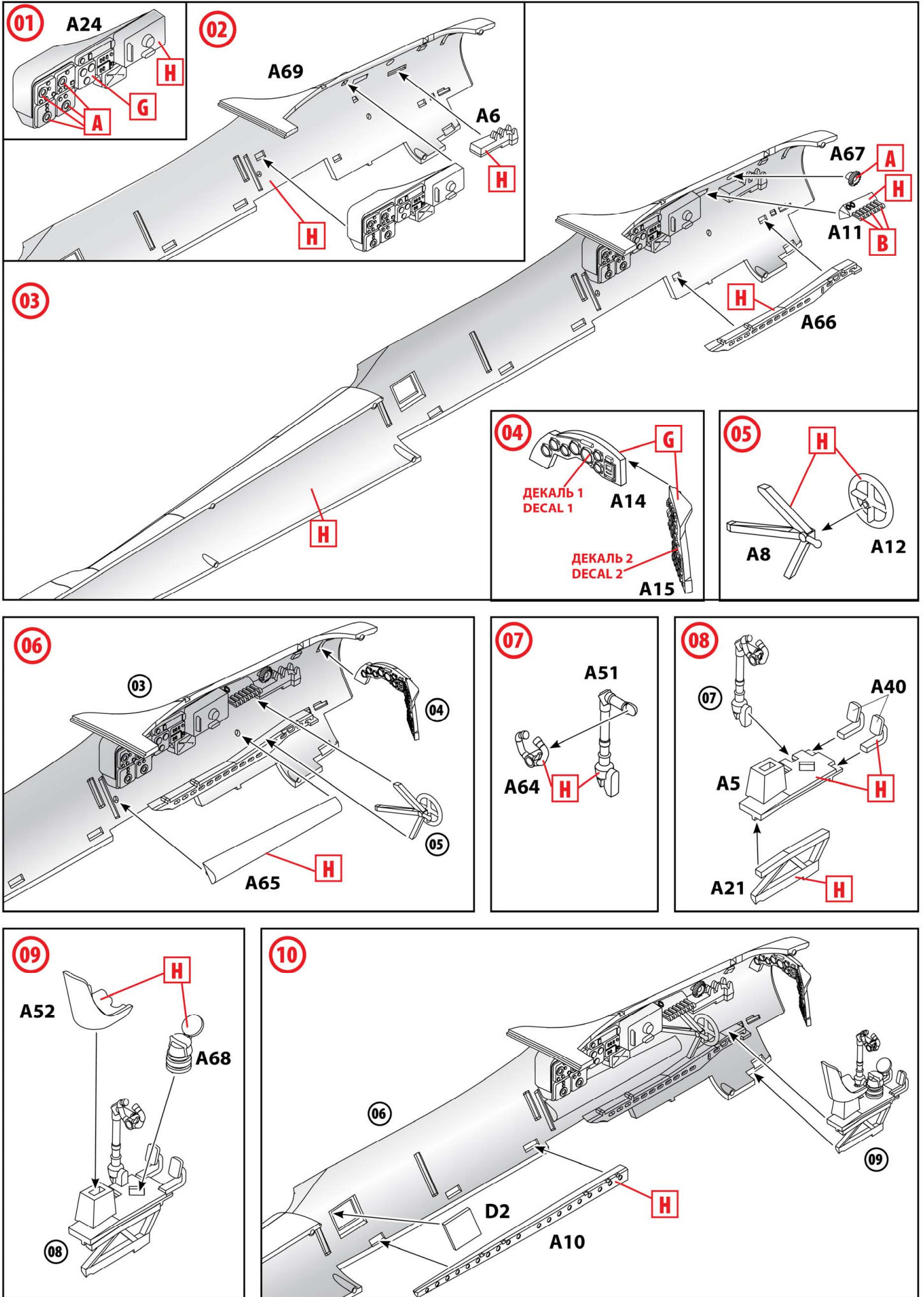

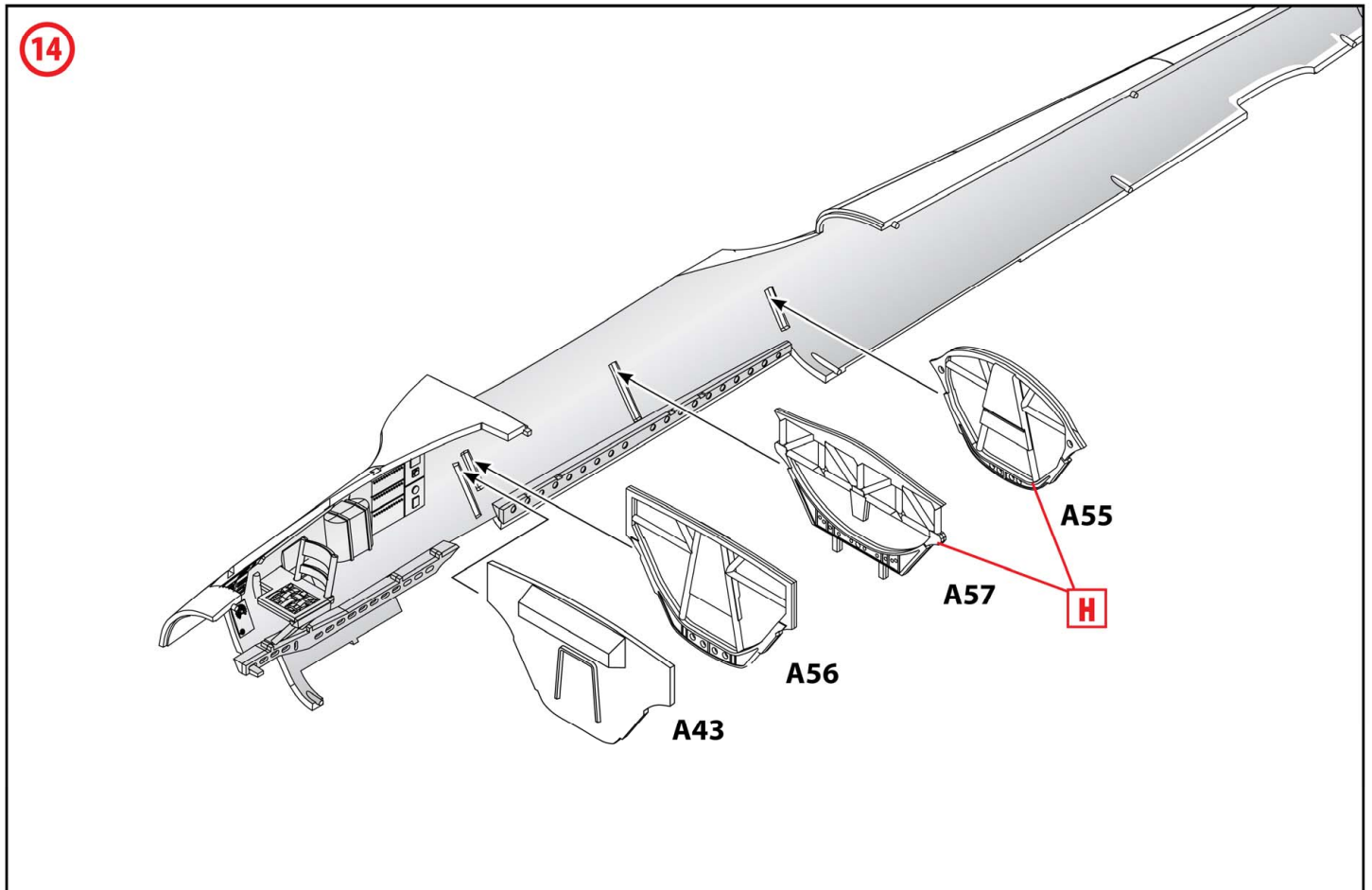
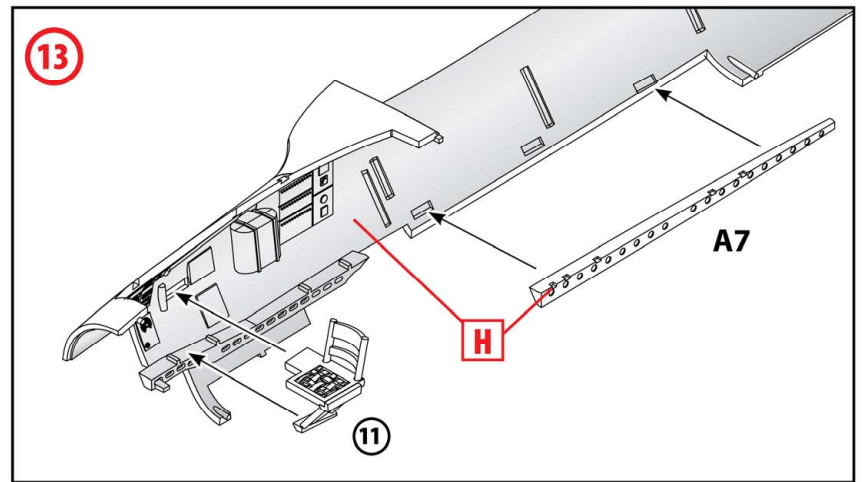
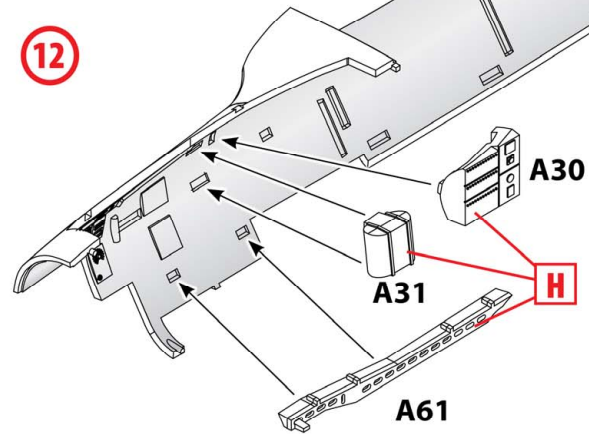
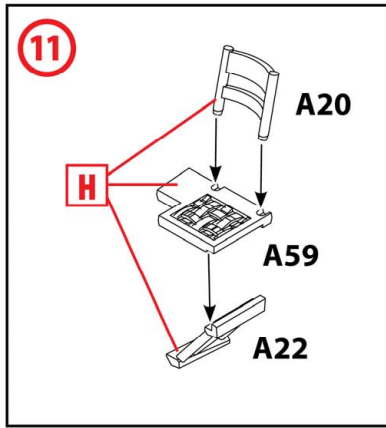

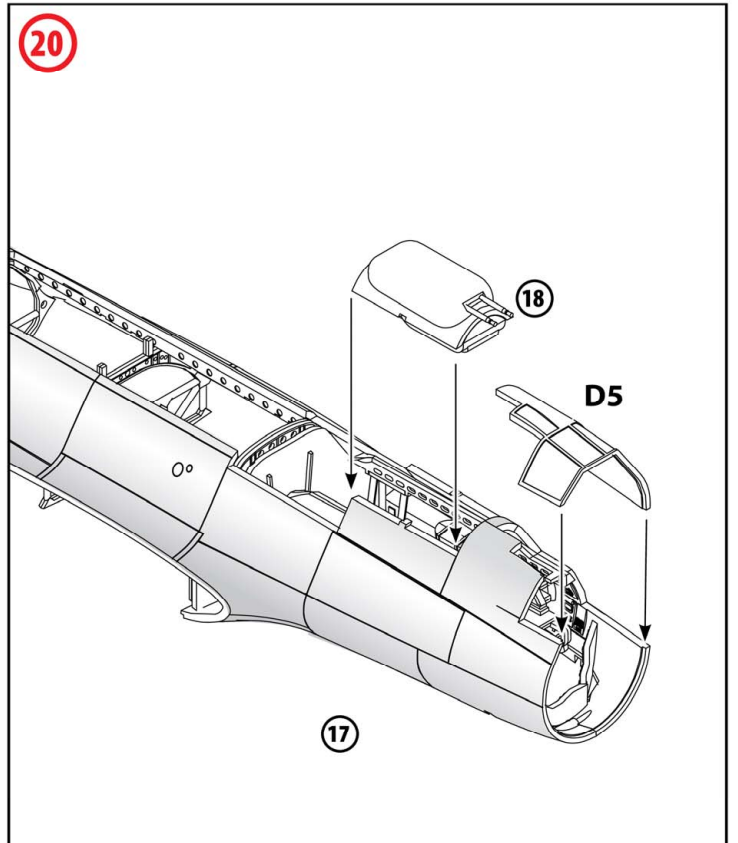
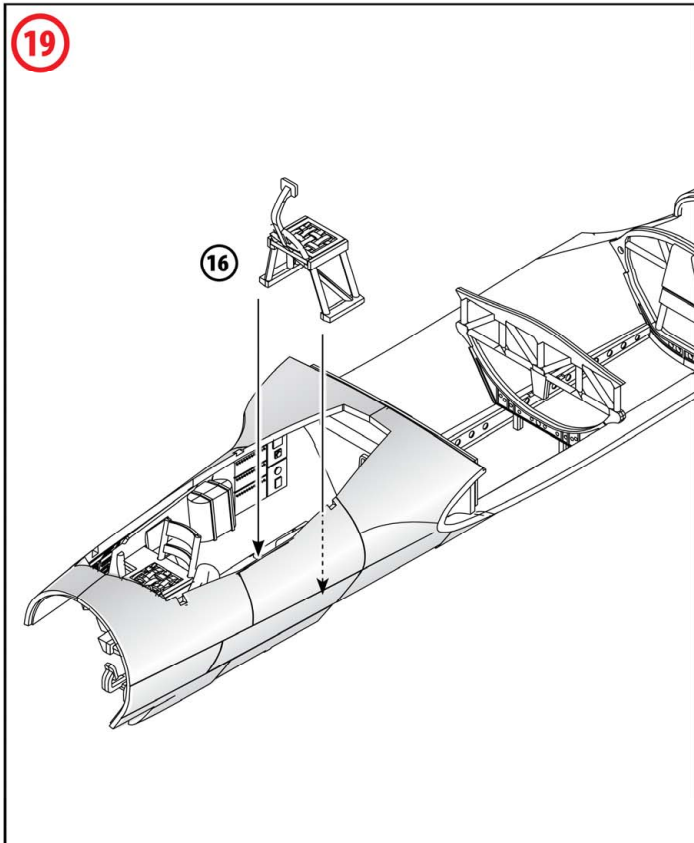
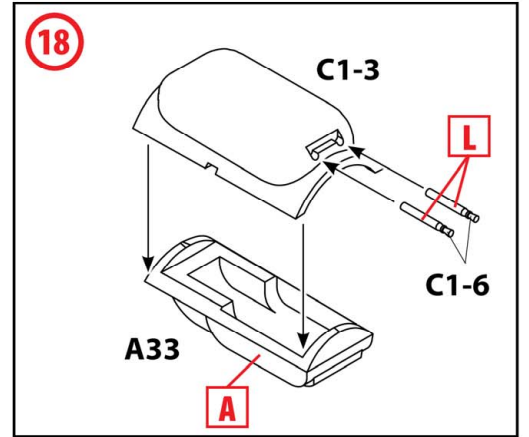
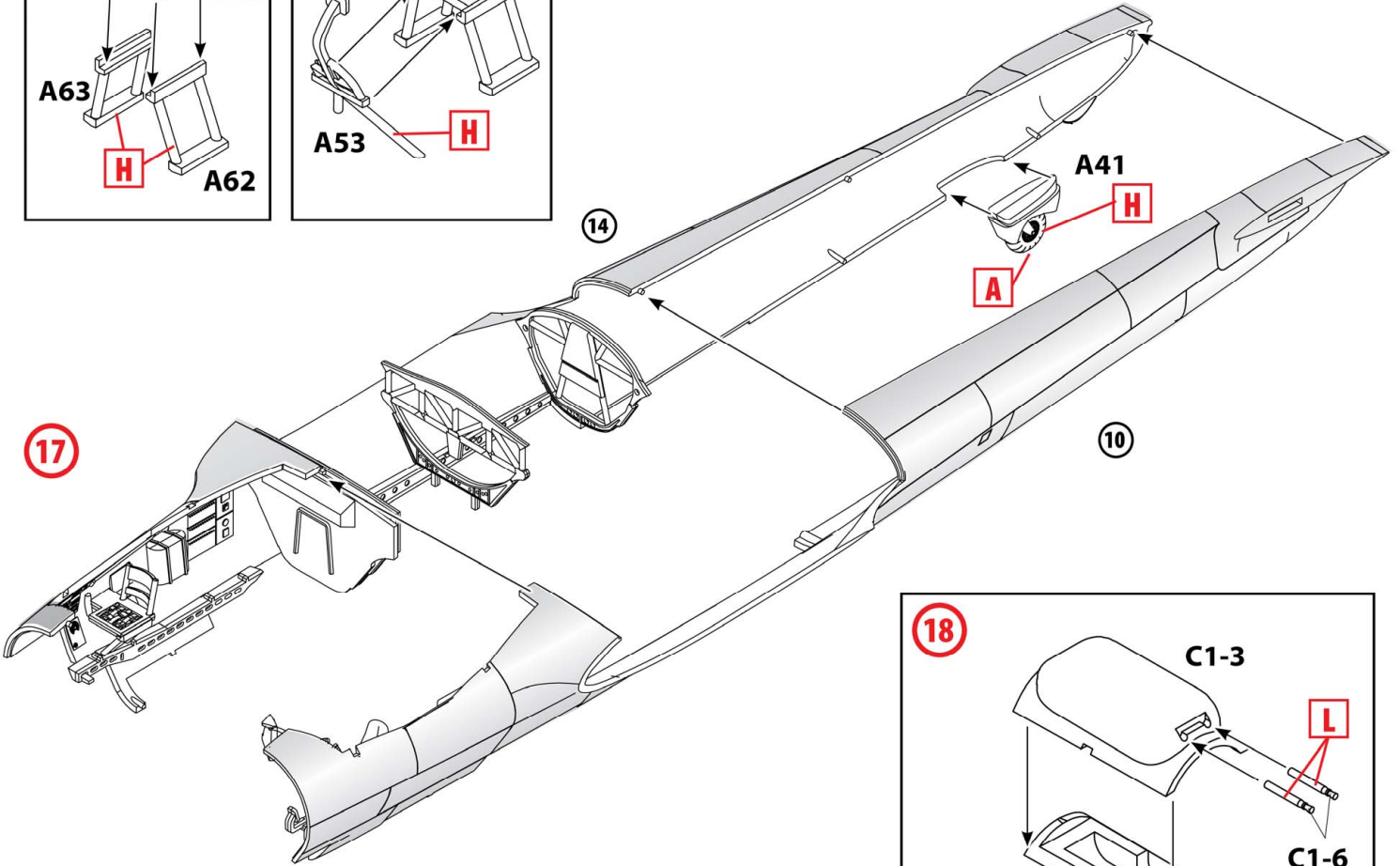
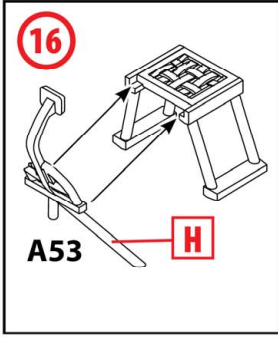
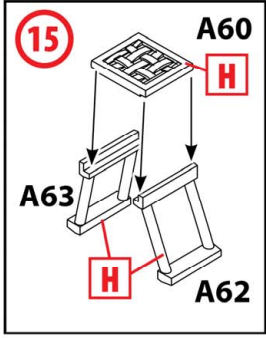

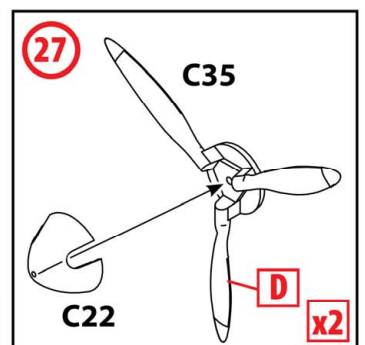
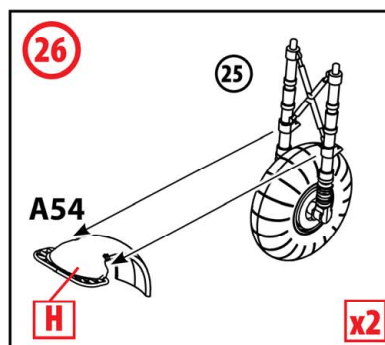
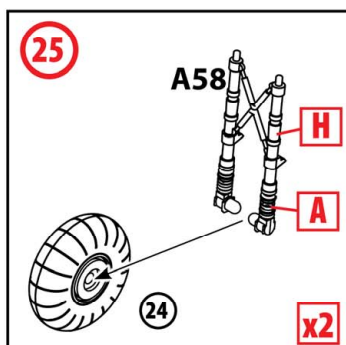
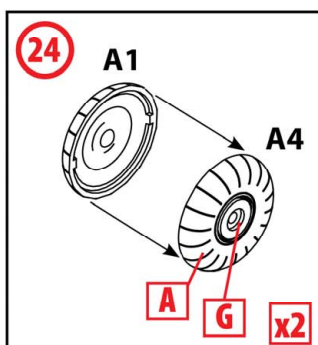
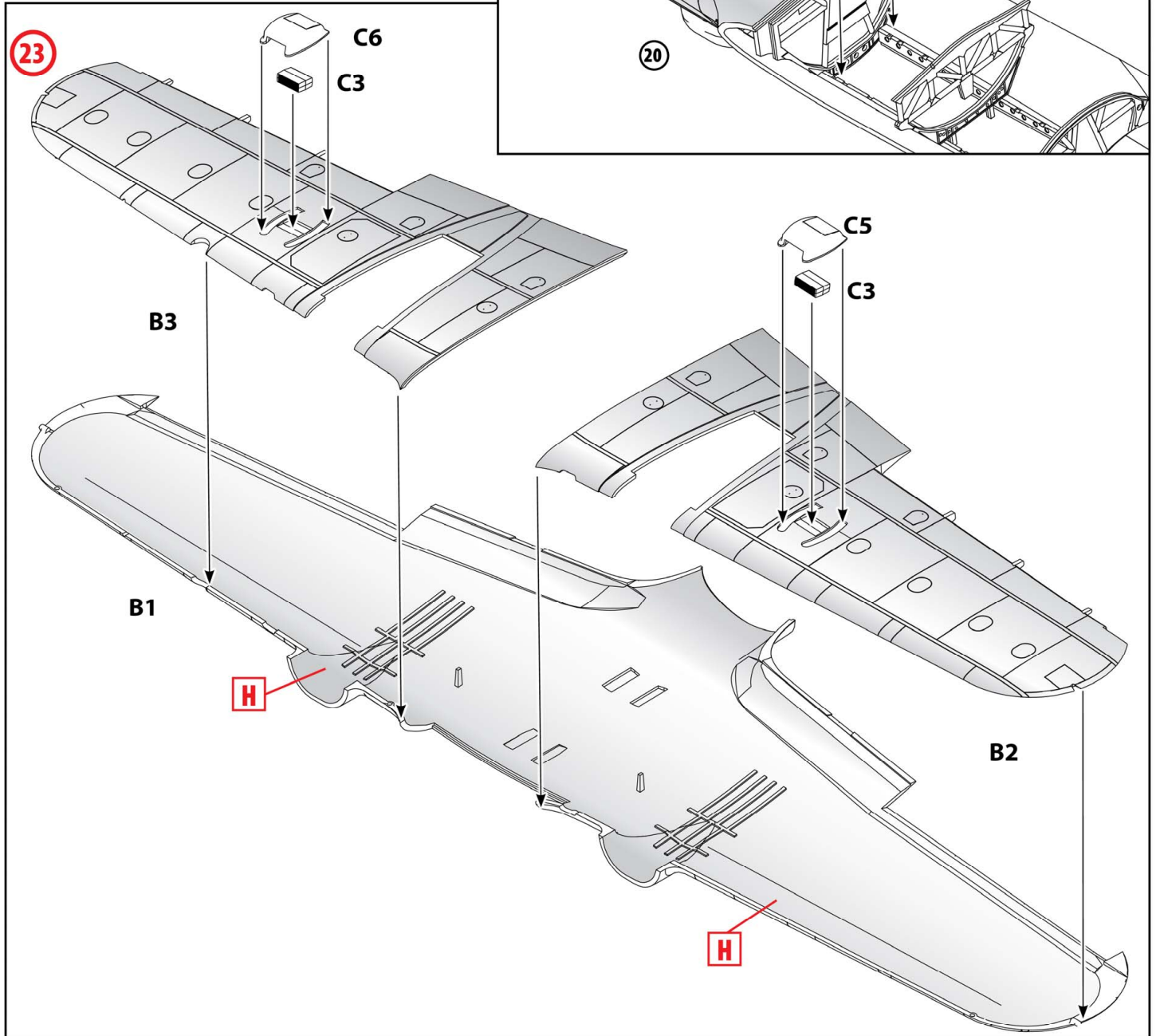
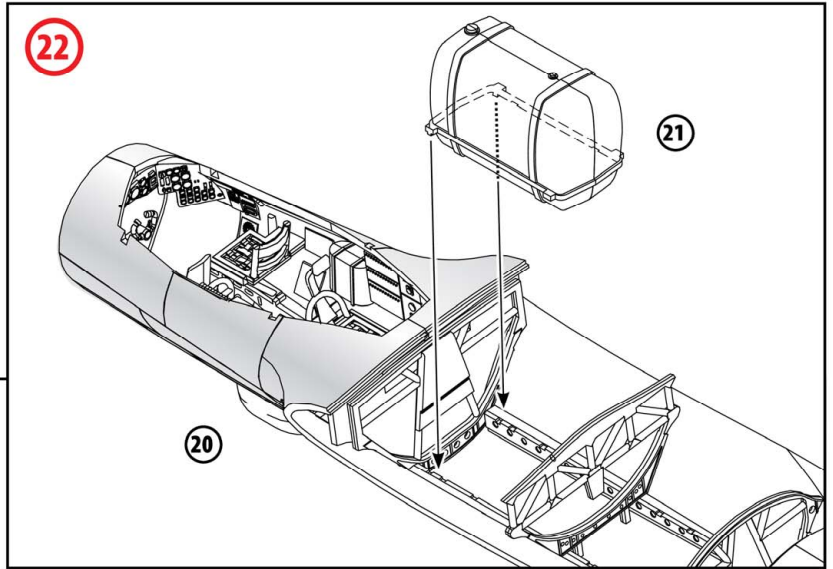
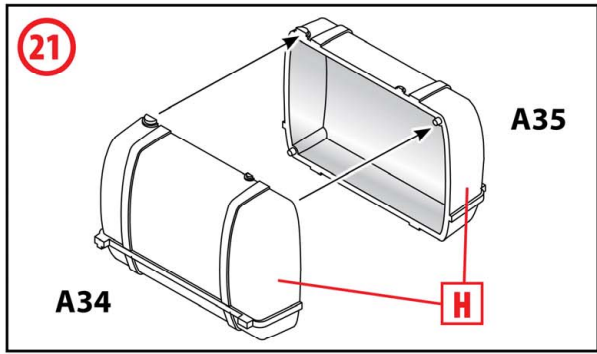

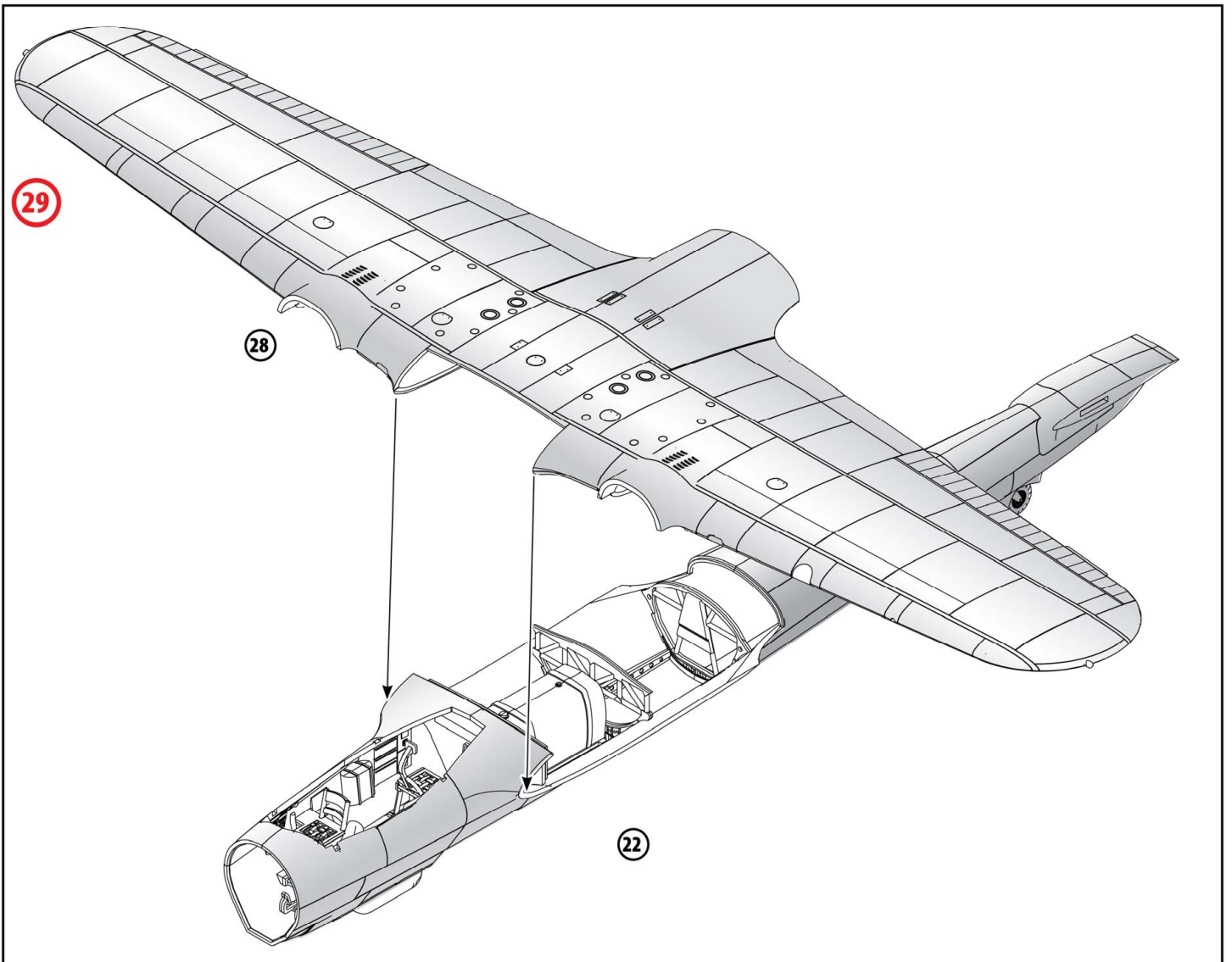
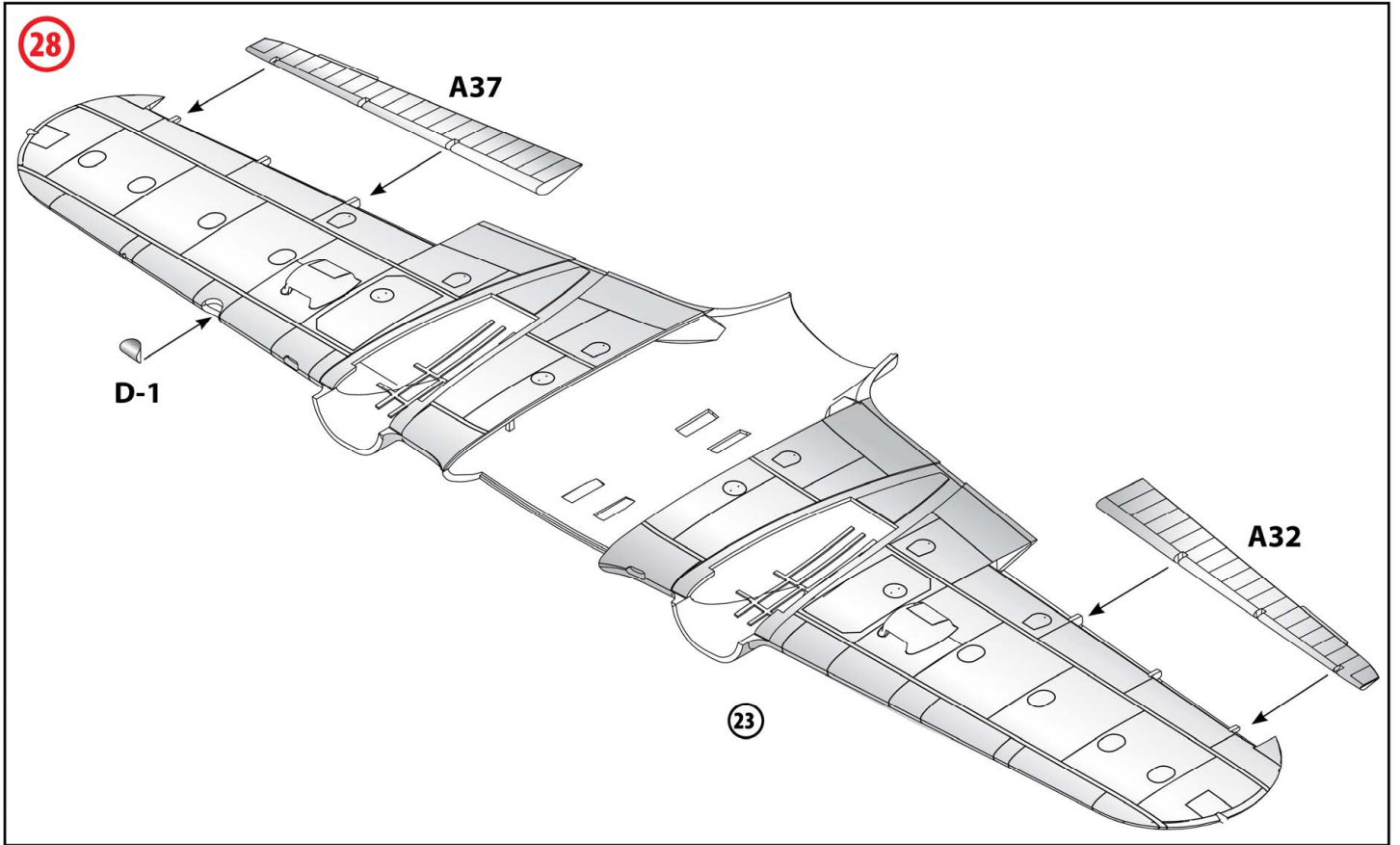

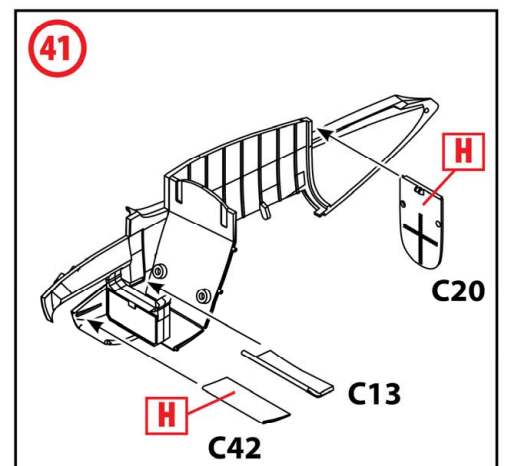
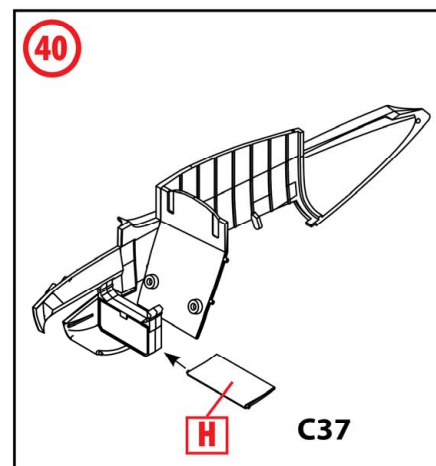
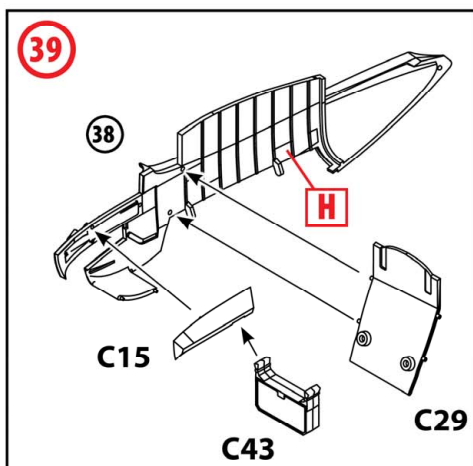
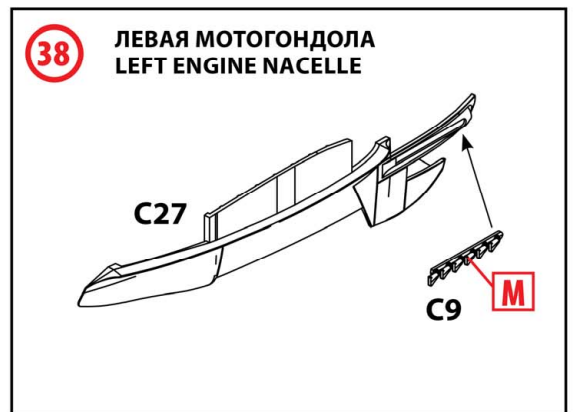
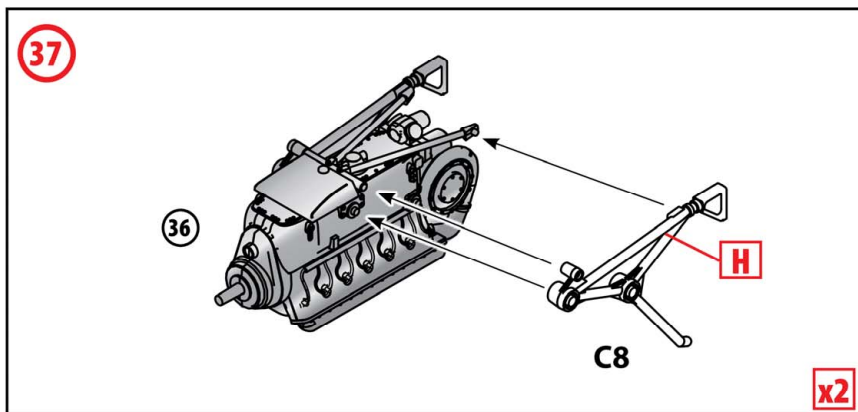
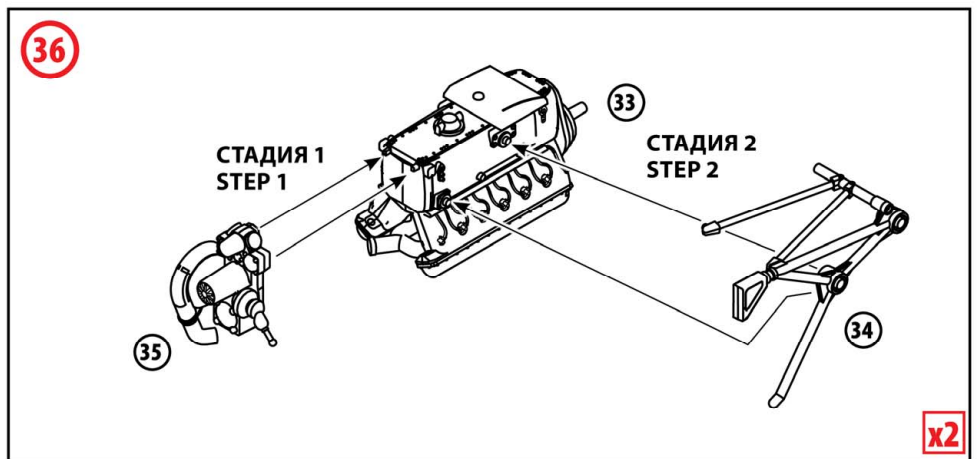
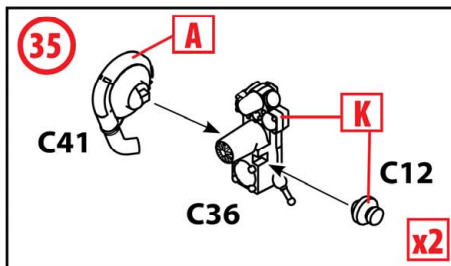
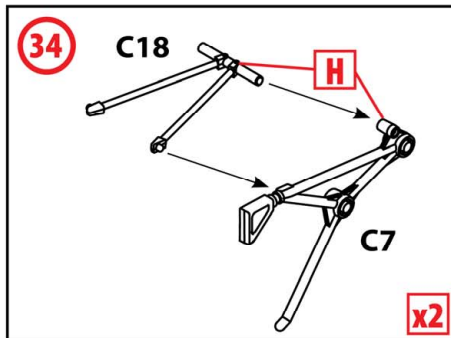
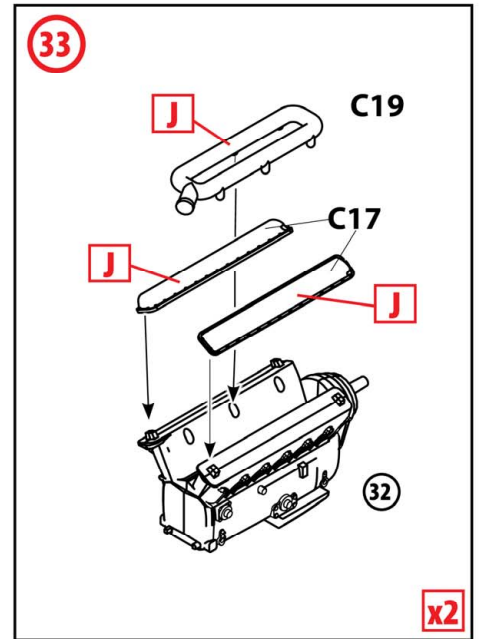
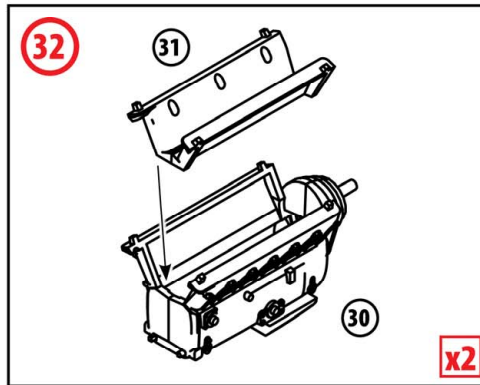
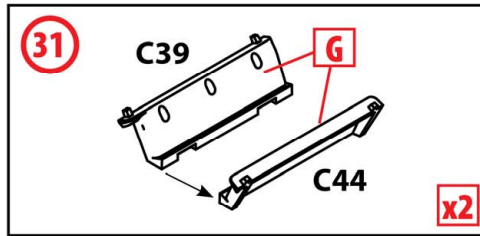
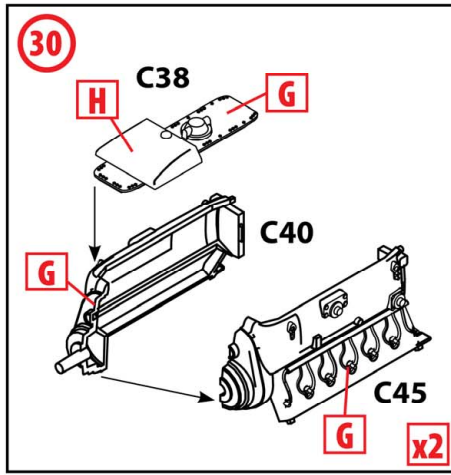

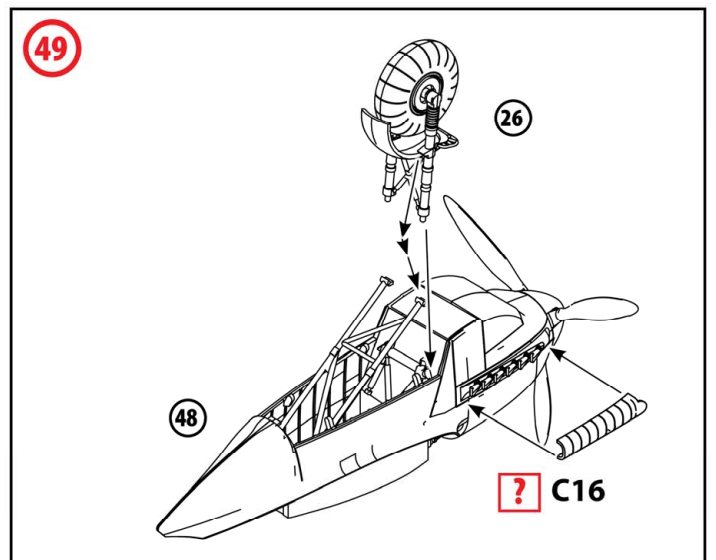
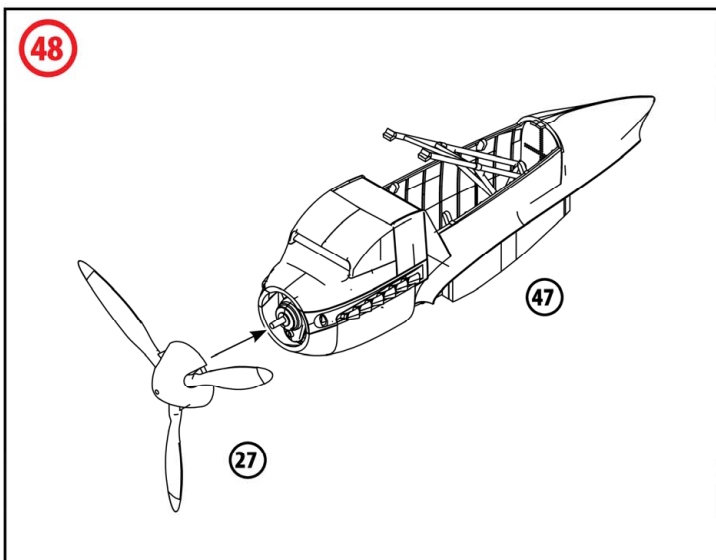
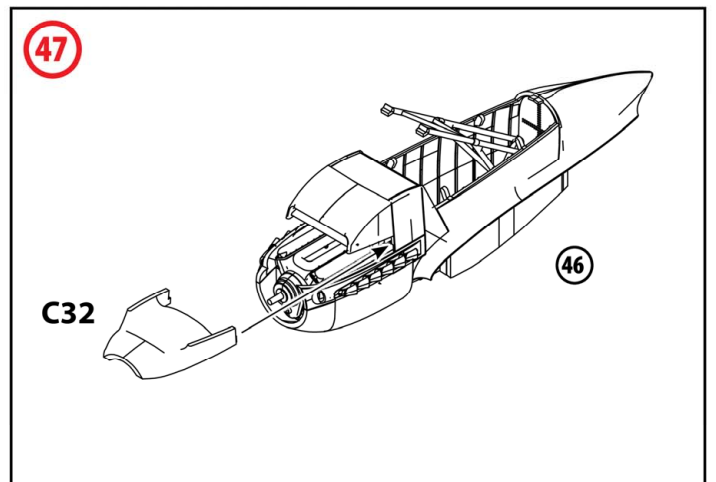
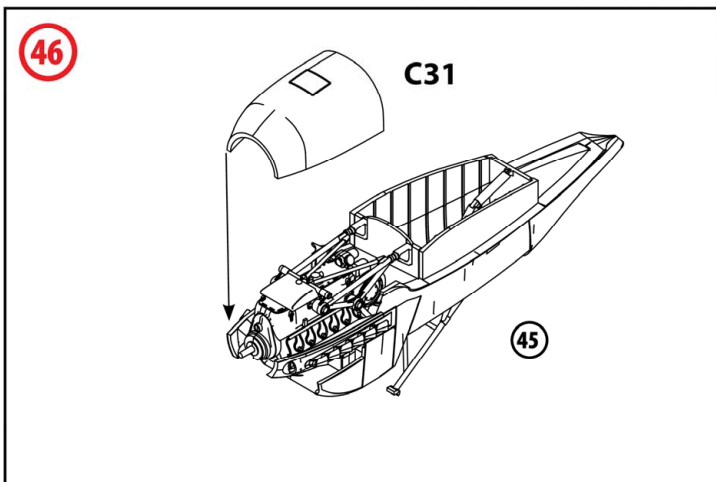
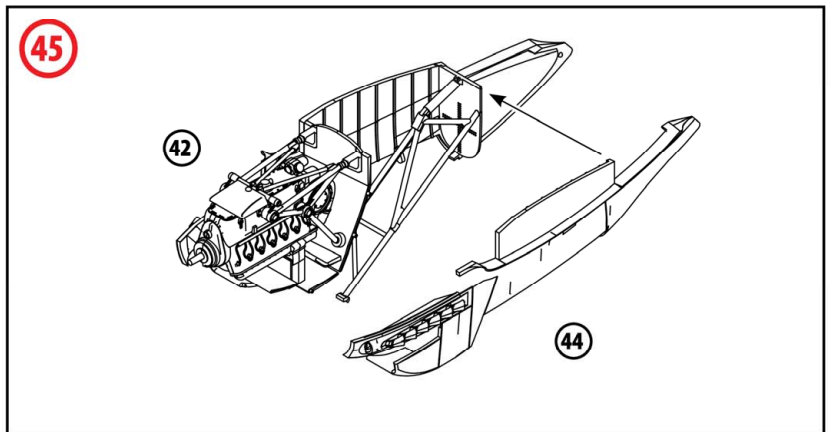
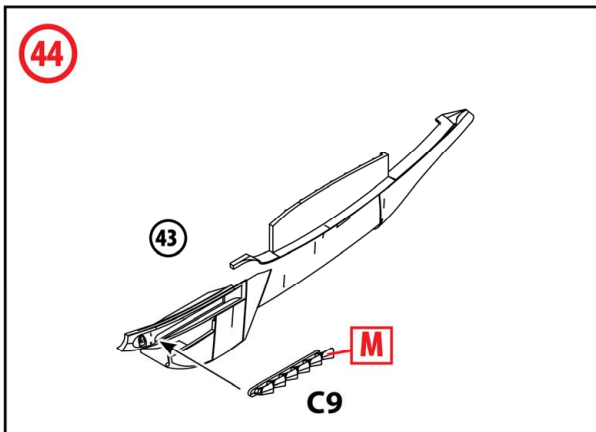
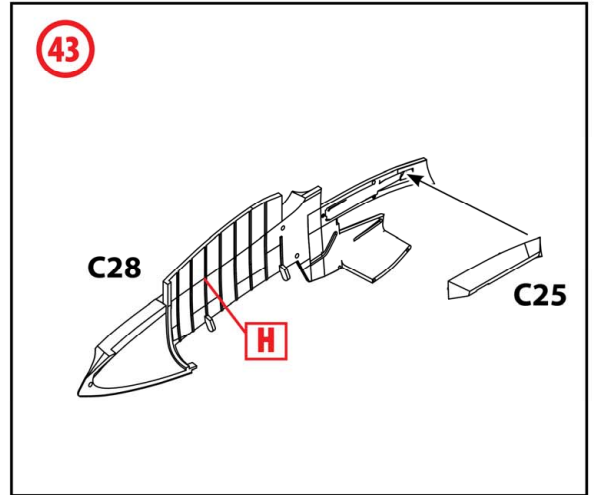
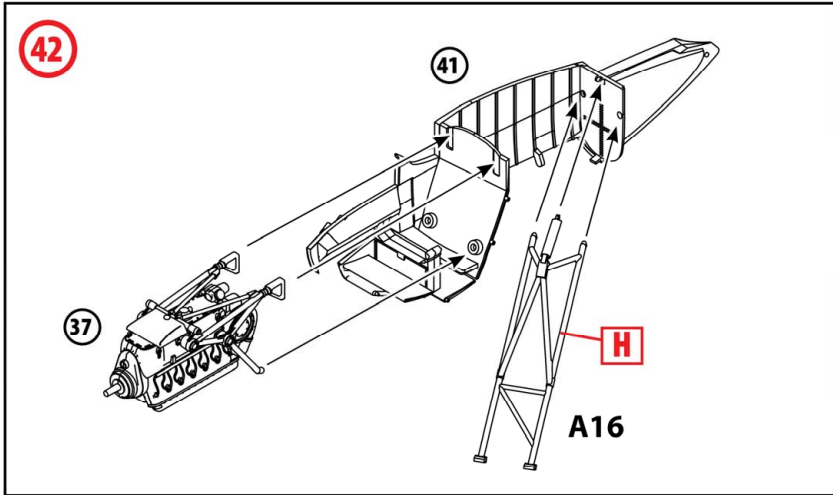

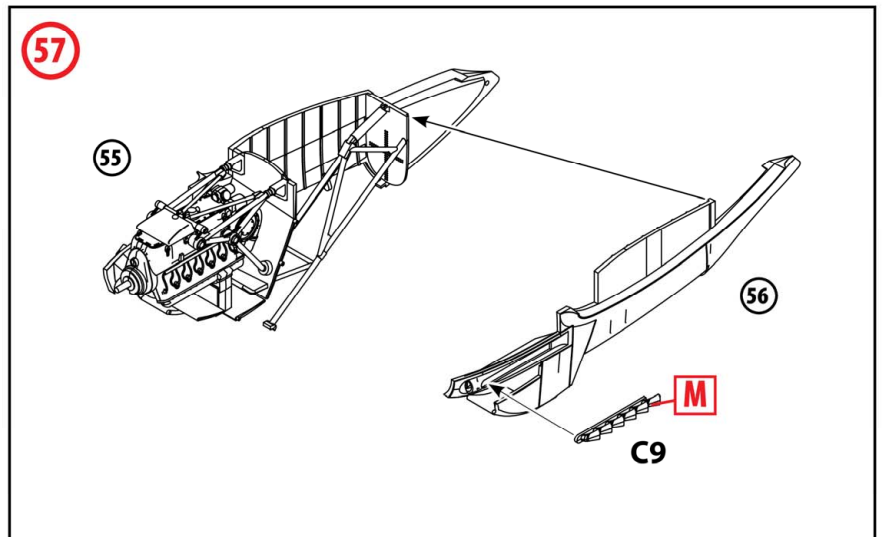
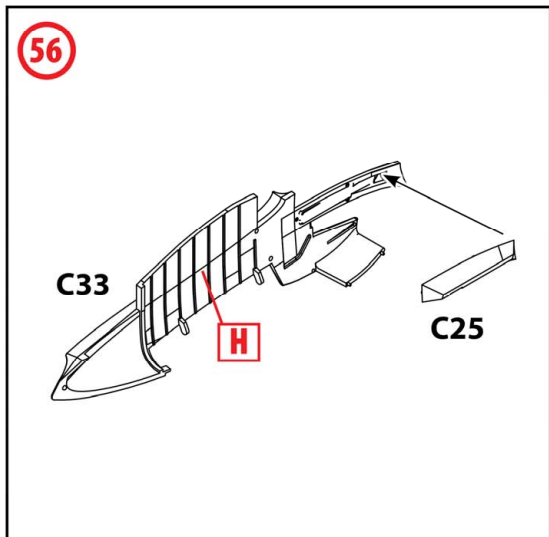
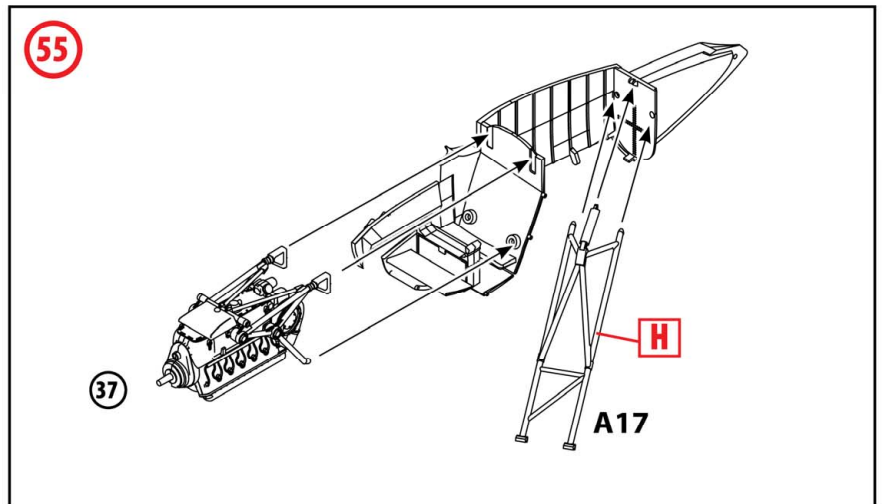
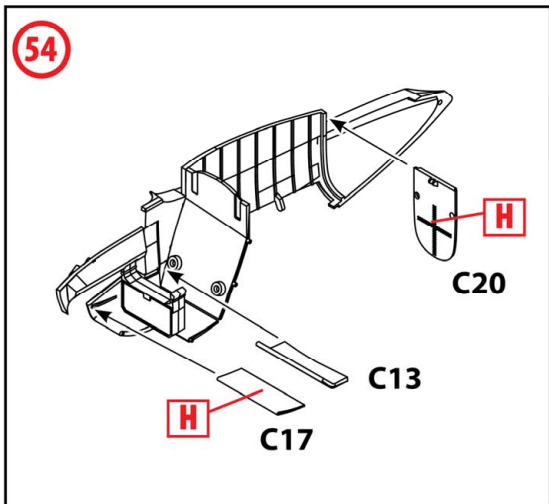
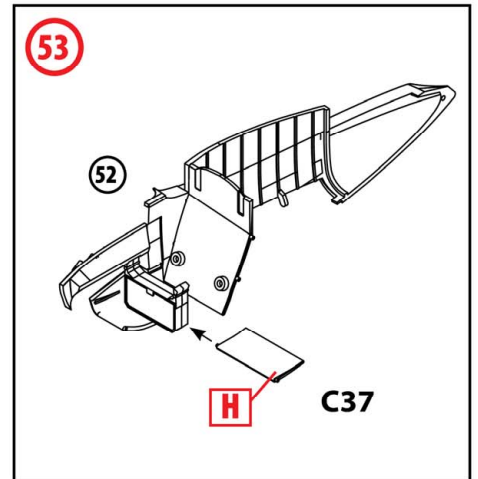
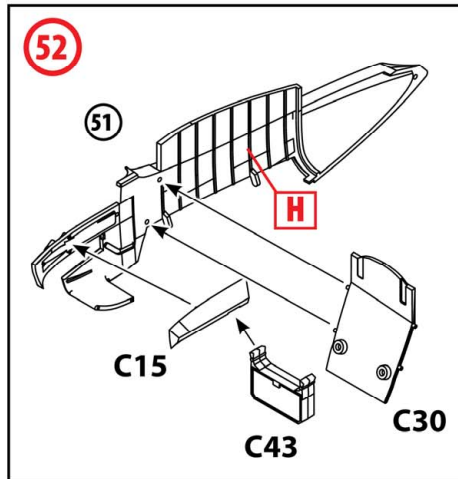
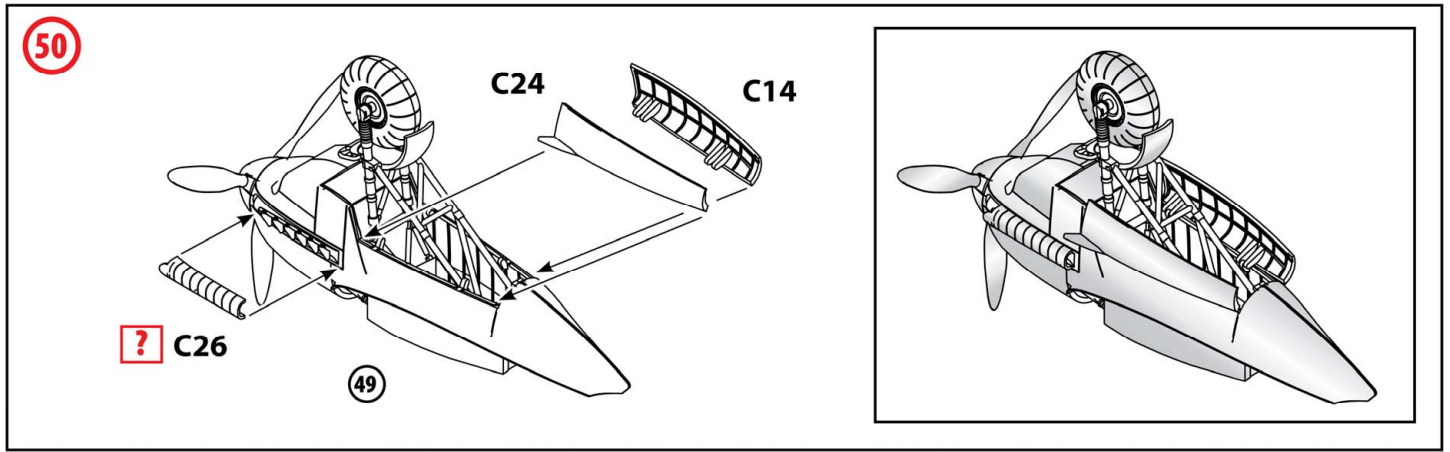

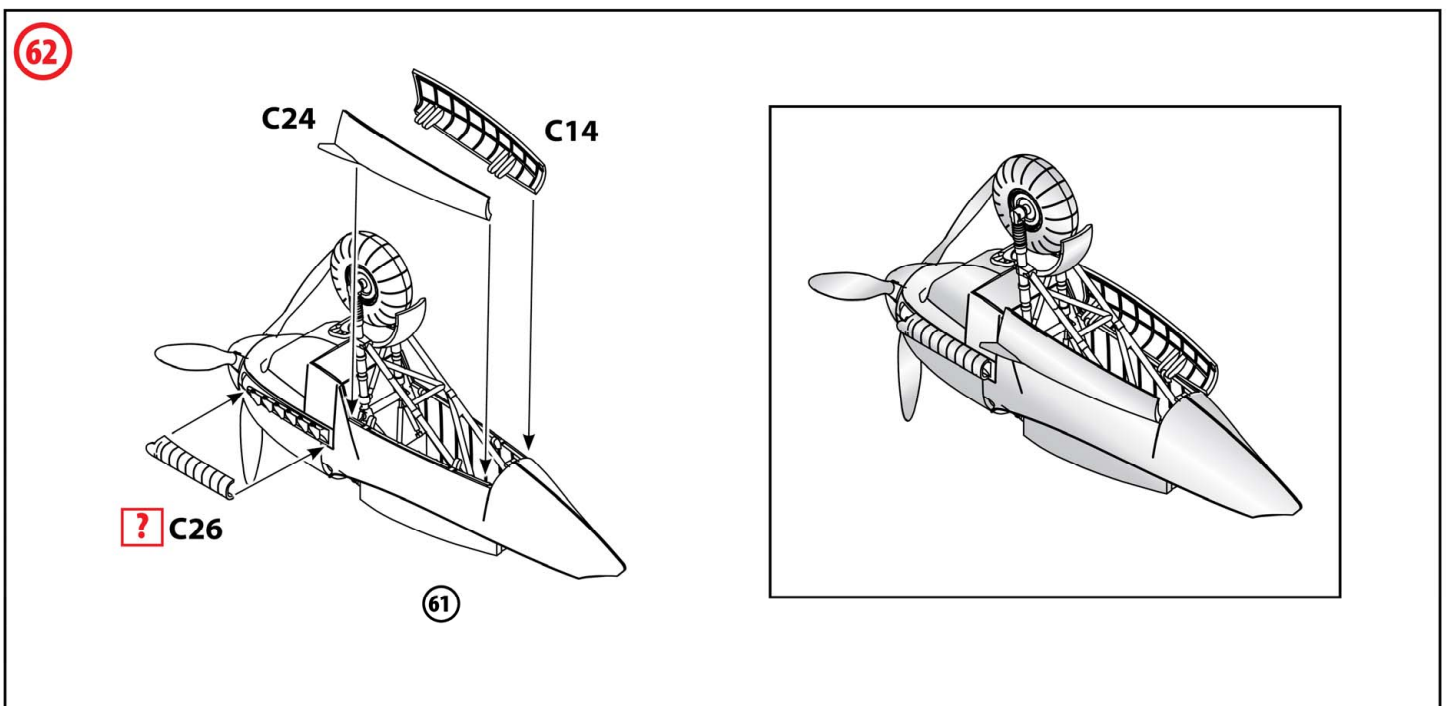
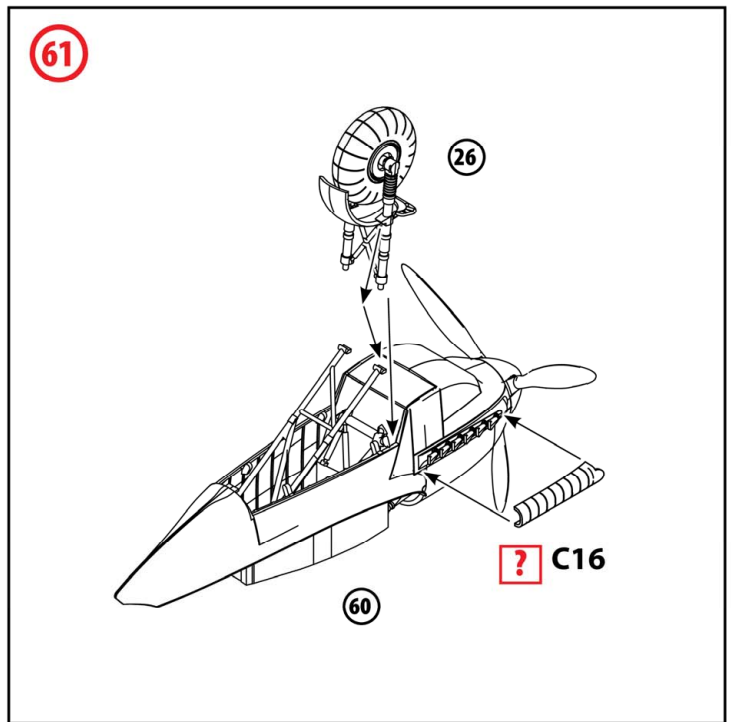
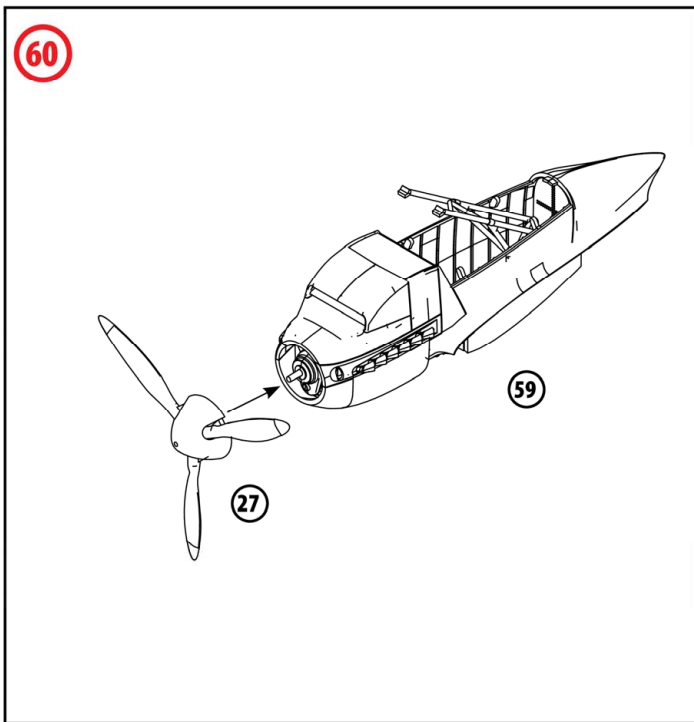
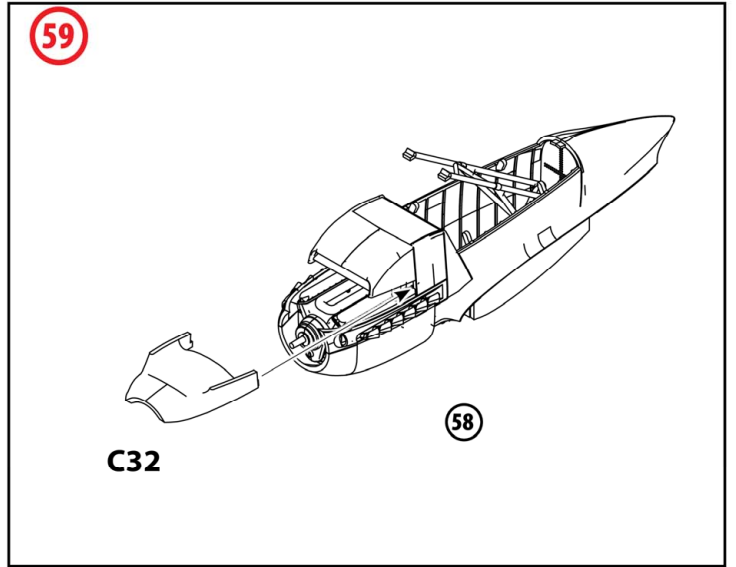
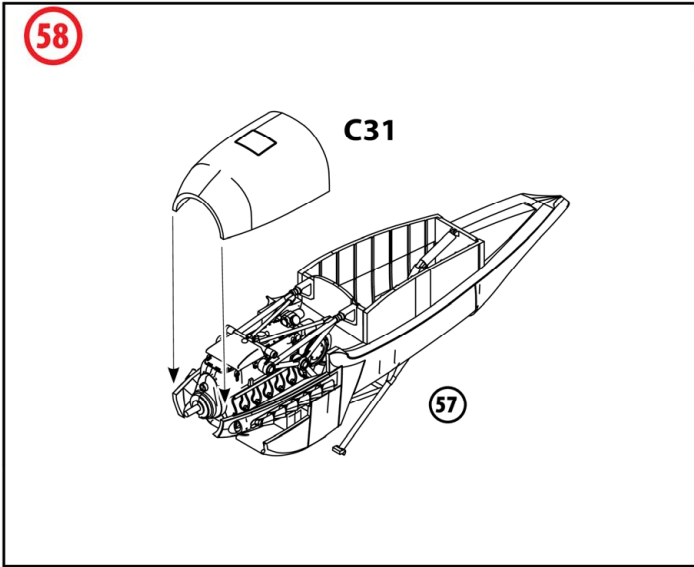

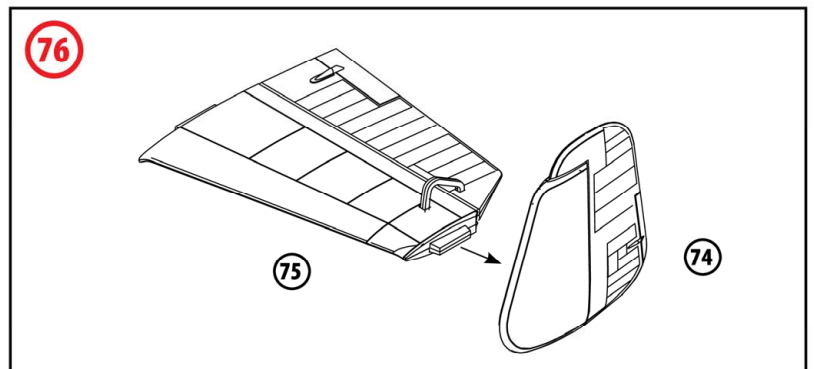
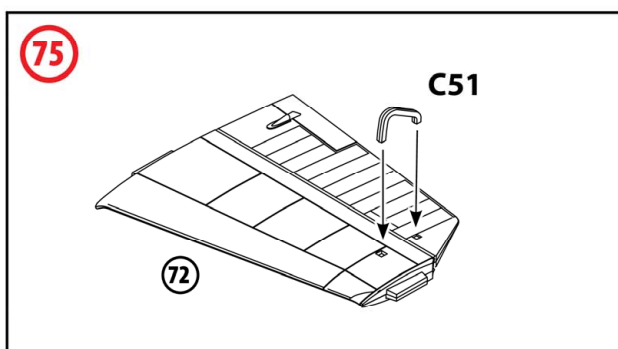
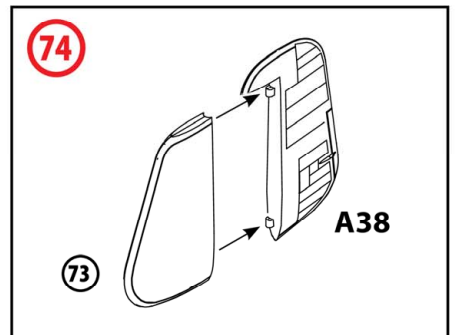
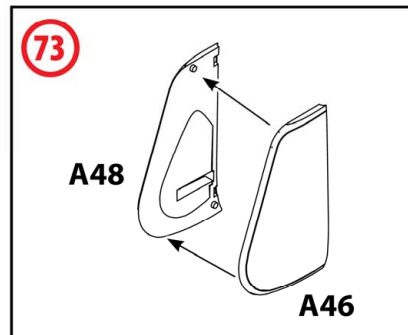
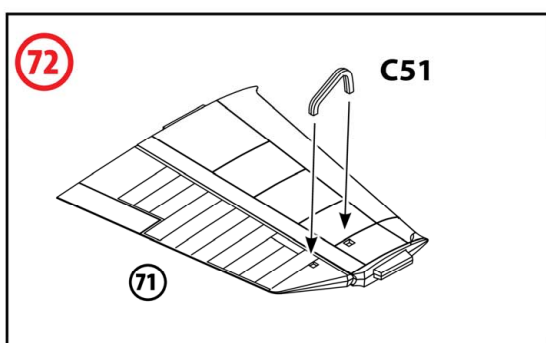
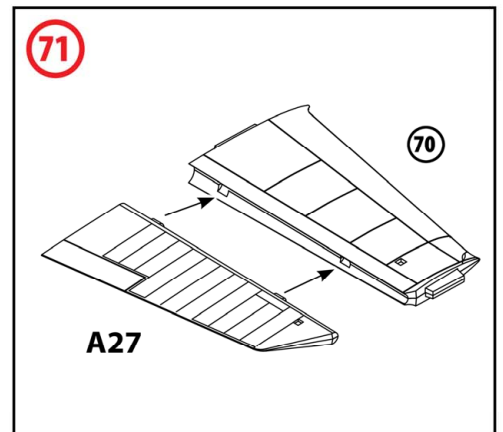
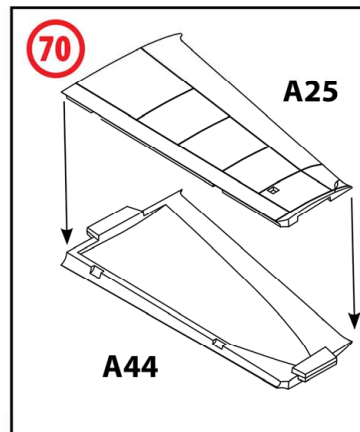
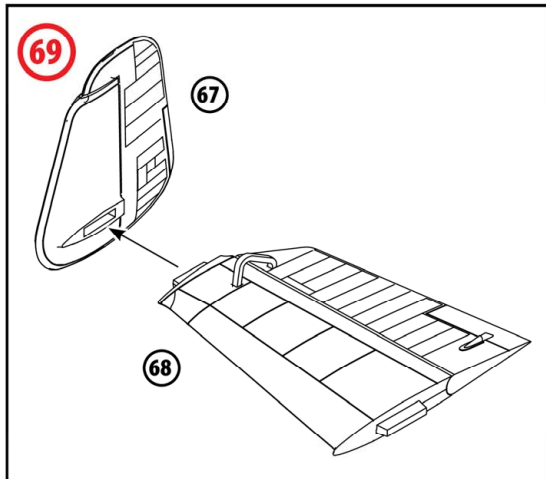
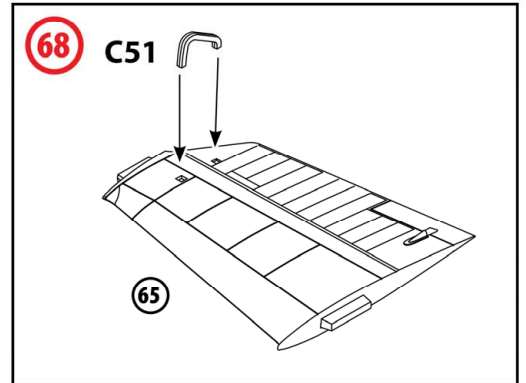
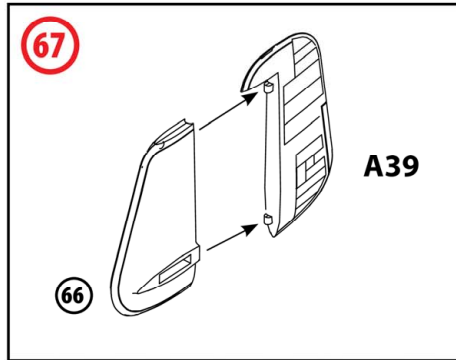
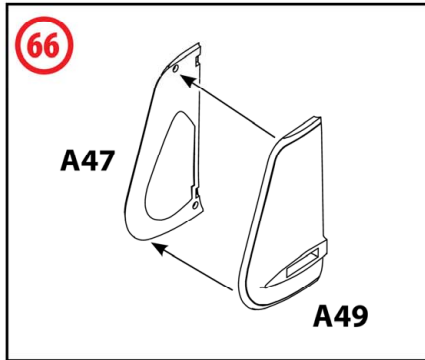
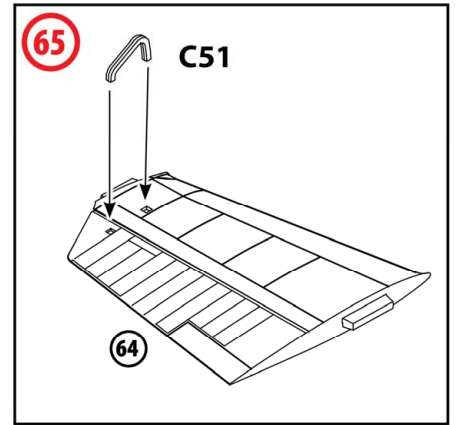
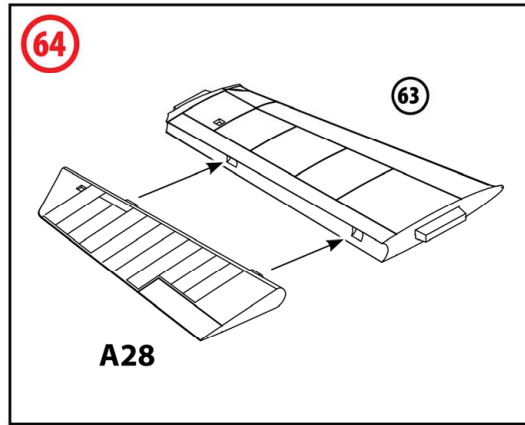
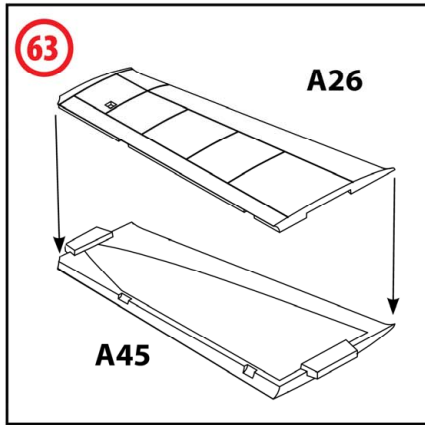

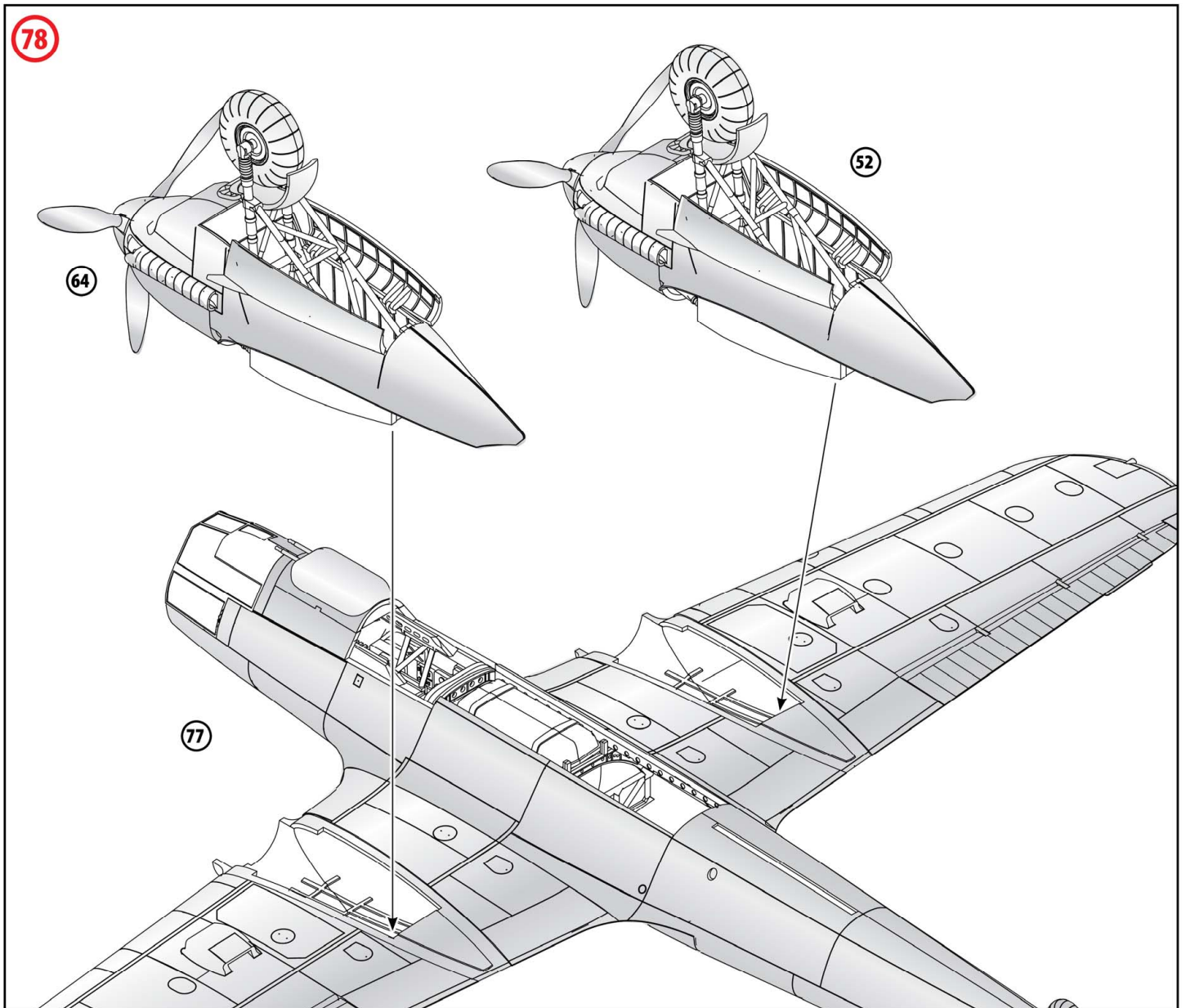
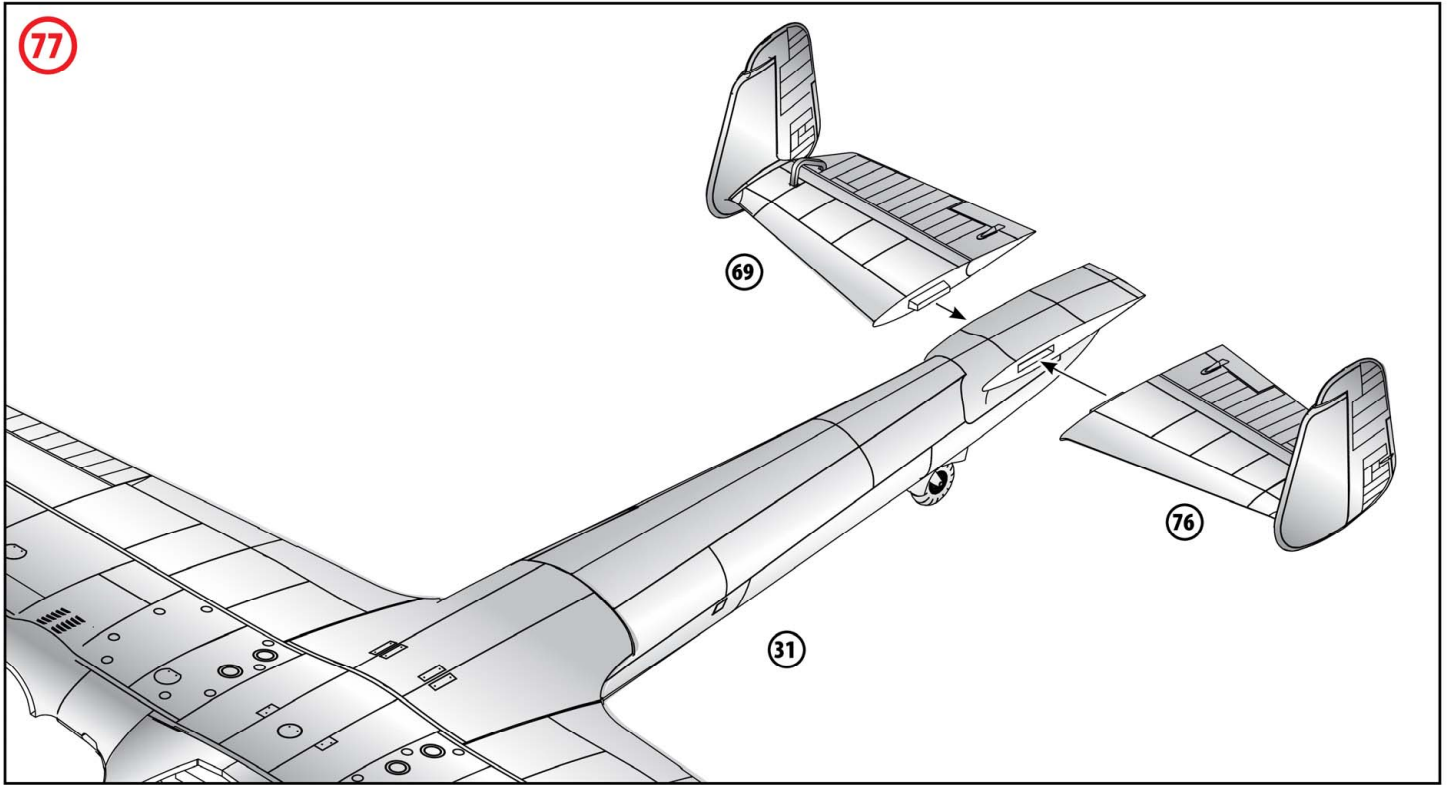

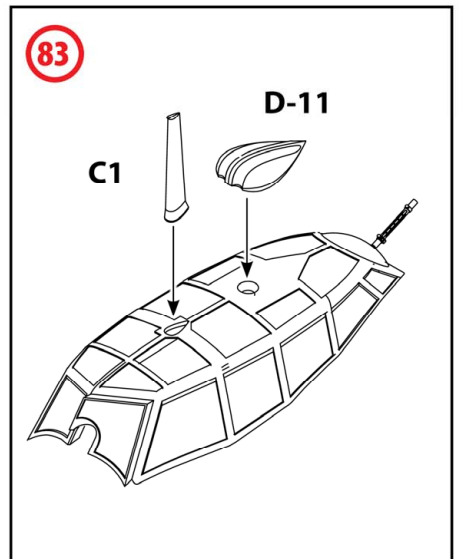
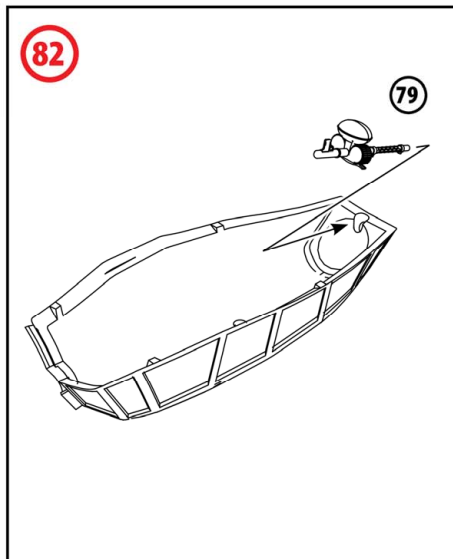
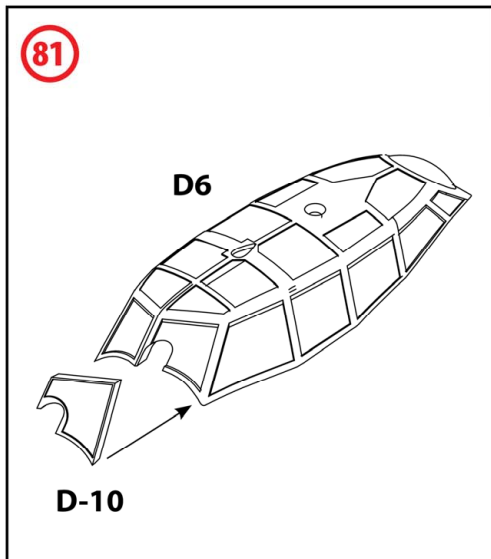
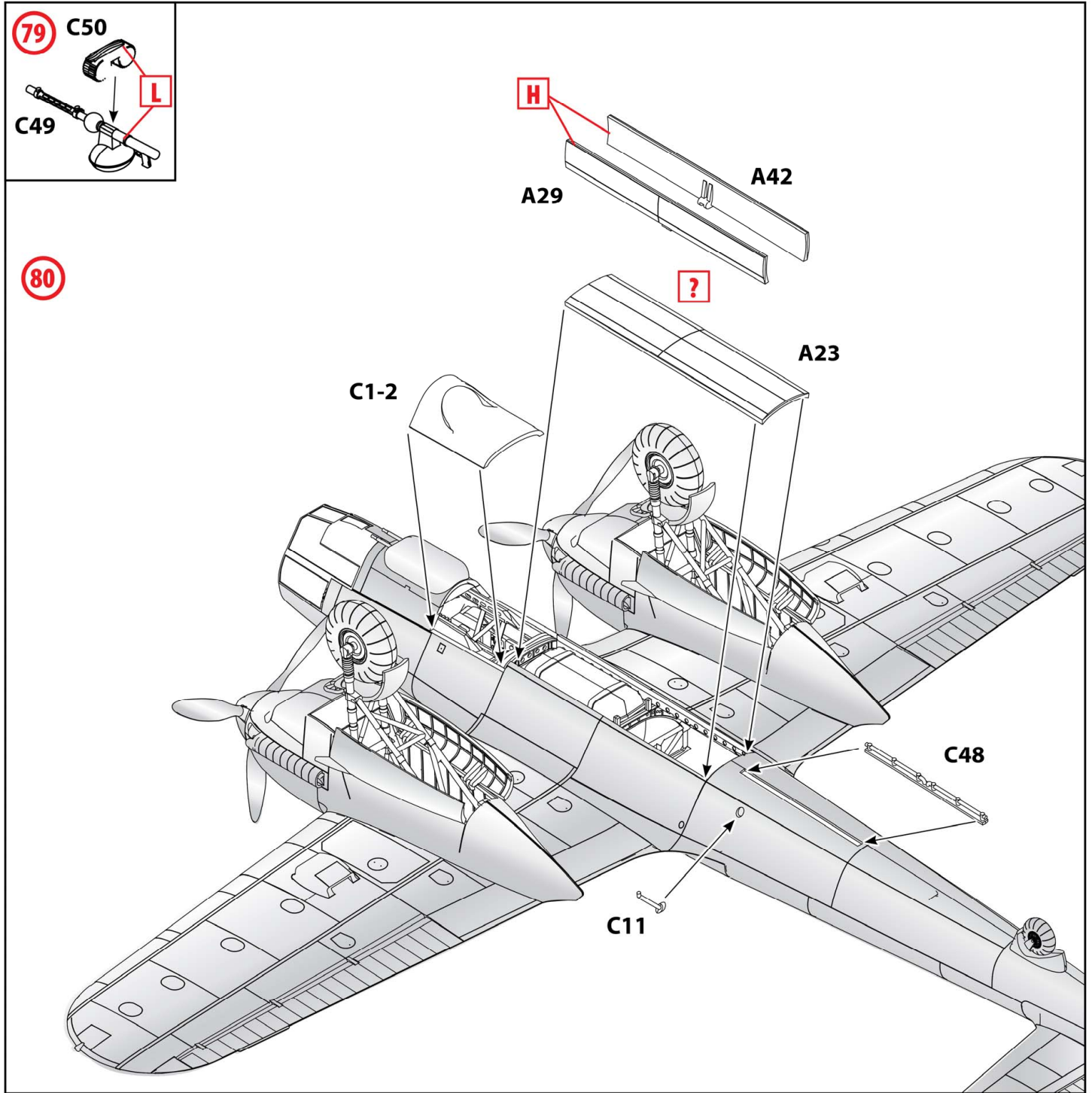

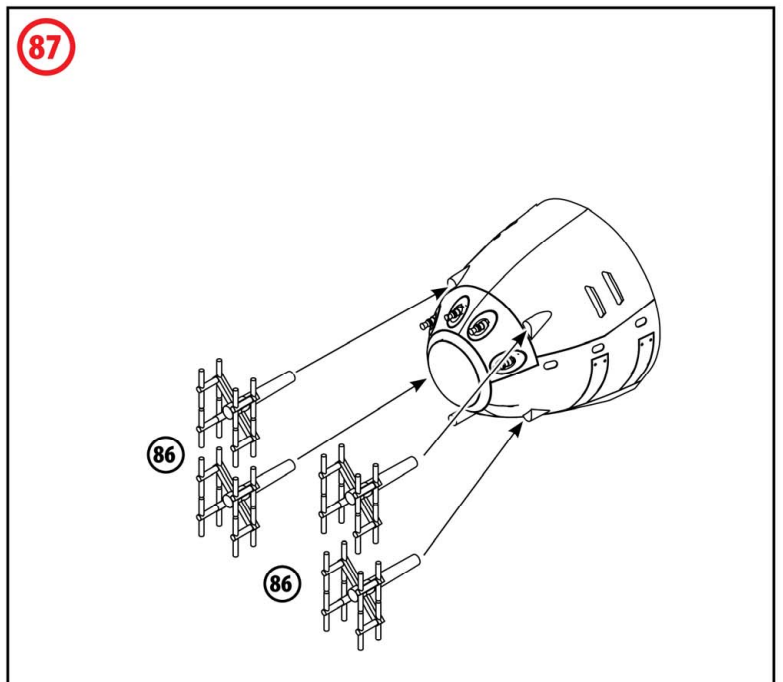
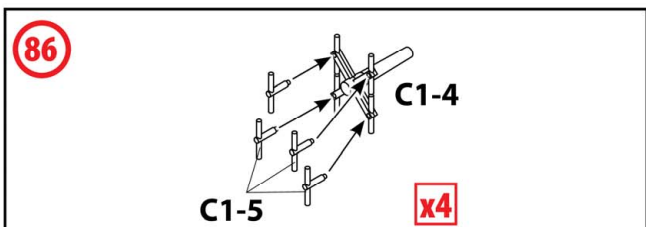
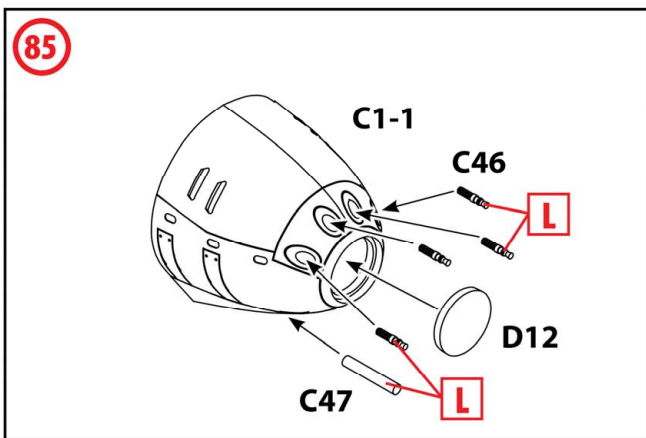
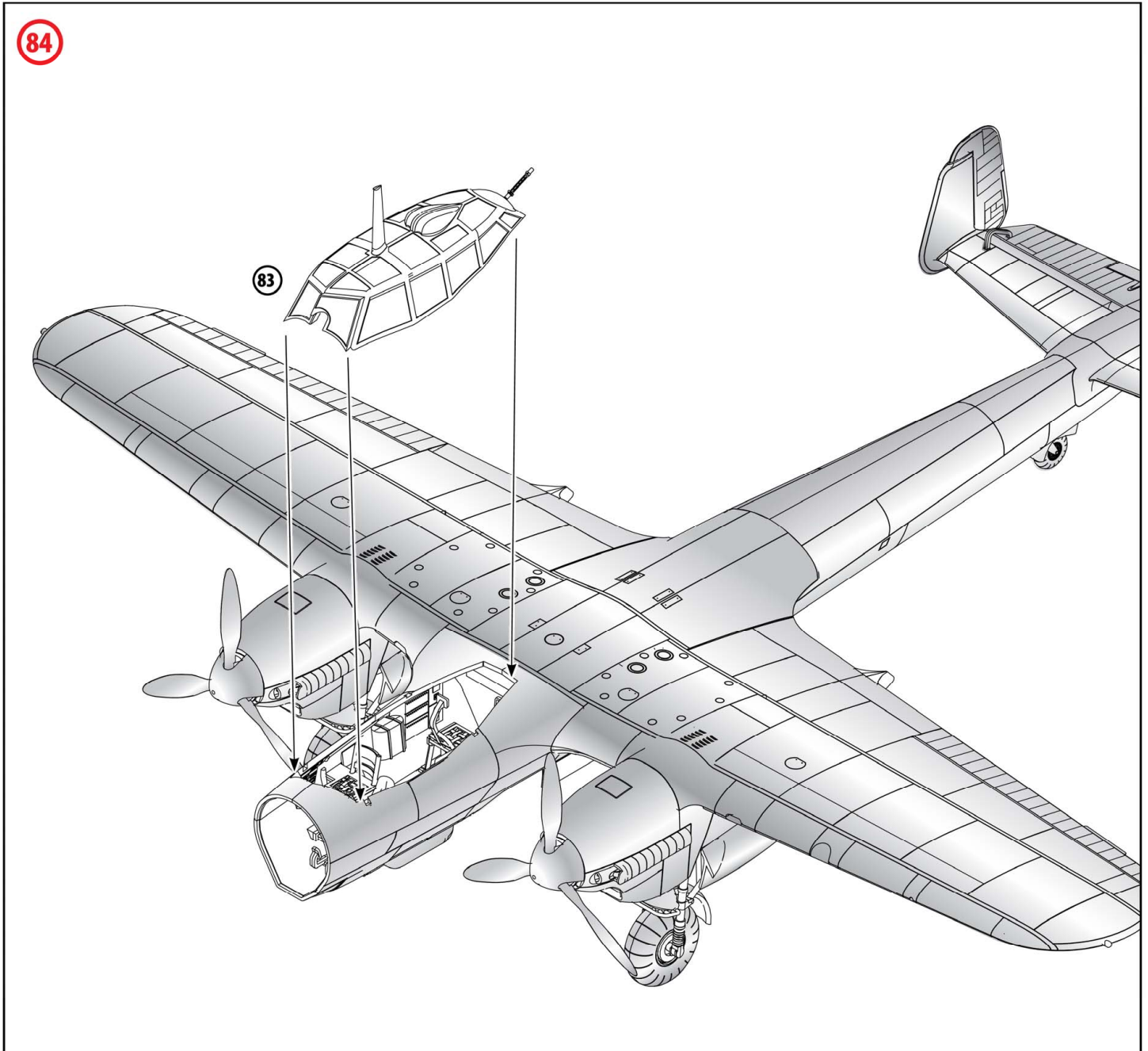

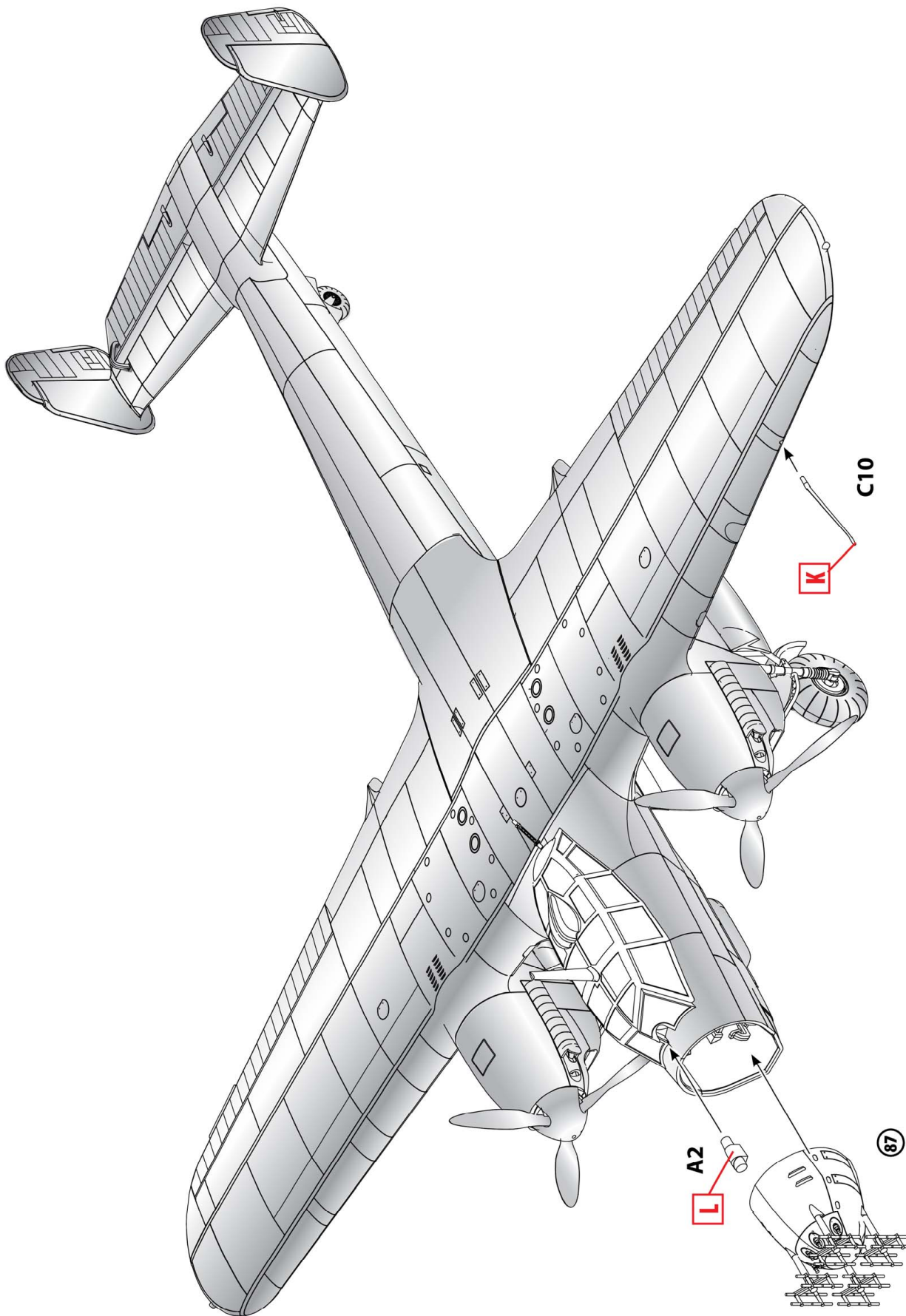

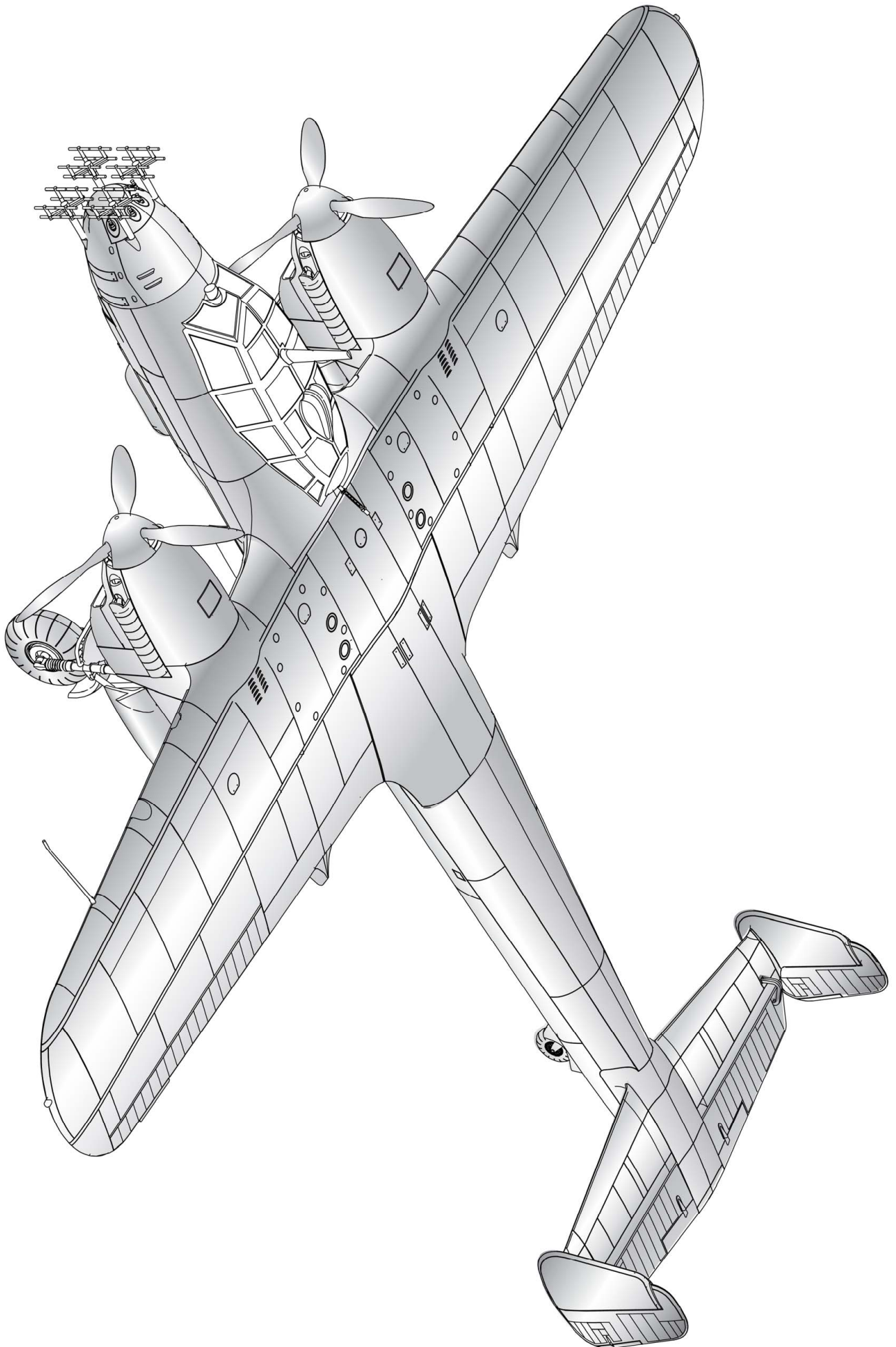

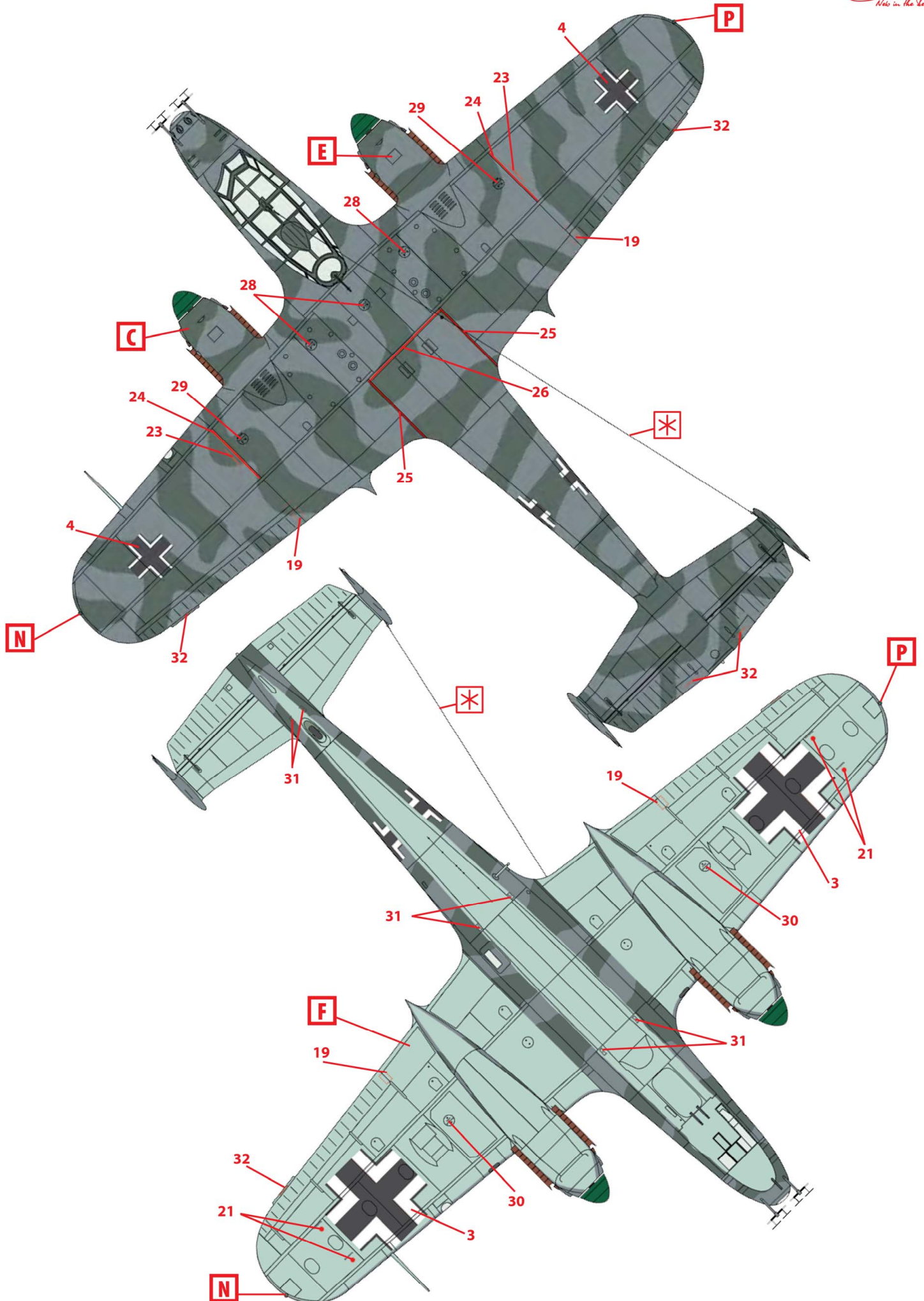

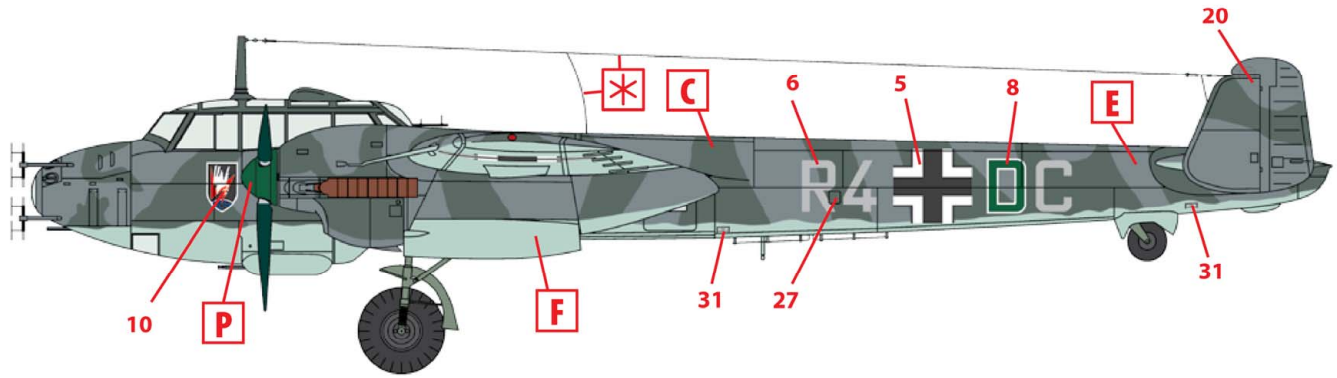

1. Dornier Do 215B-5, Stab II./NJG 2, Леуварден, весна 1942 г.
Dornier Do 215B-5, Stab II./NJG 2, Leeuwarden, Spring 1942

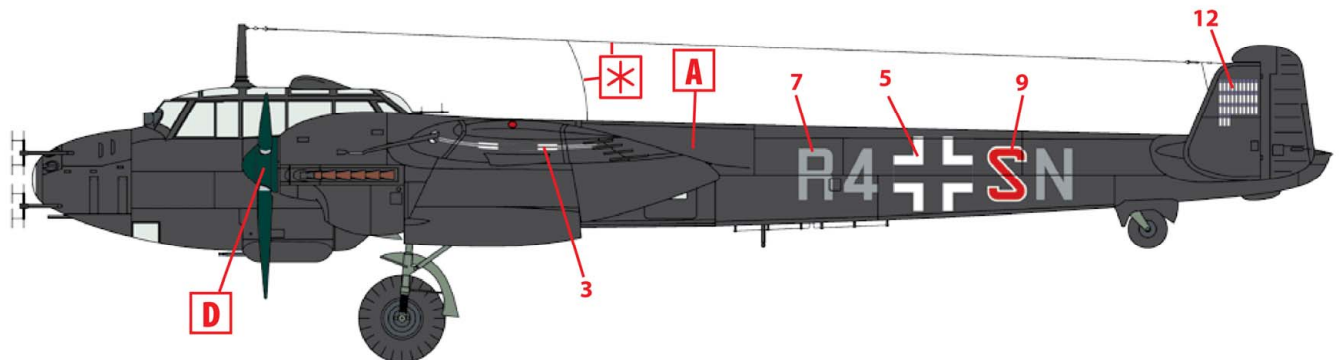
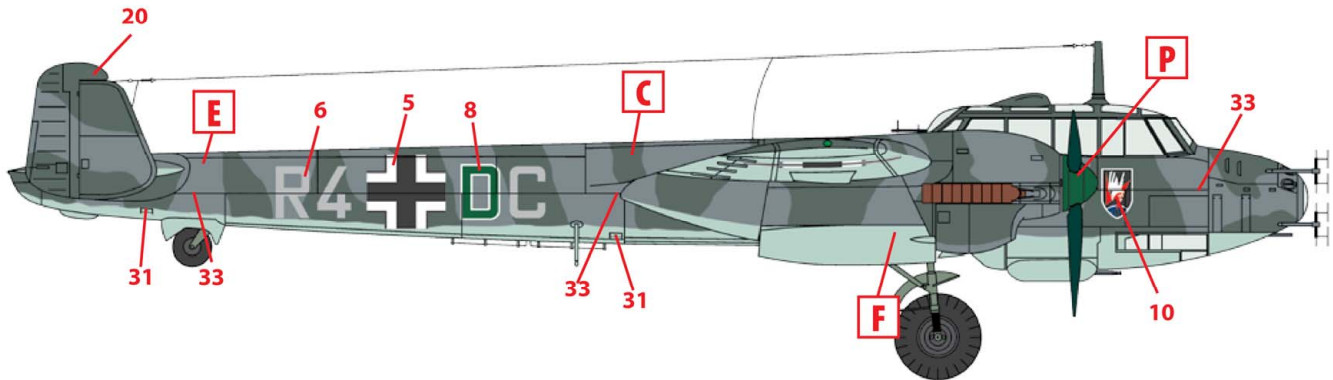

2. Dornier Do 215B-5, Оберлейт. П. Гилднер, II./NJG 2, Гилце-Рийен, осень 1941 г.
Dornier Do 215B-5, Oblt. P. Gildner, II./NJG 2, Giltze-Rijen, Autumn 1941

