

# CR. 42 Falco

1/32 SCALE MODEL KIT №32020

## CR. 42 Falco Итальянский истребитель ИИМБ

Fiat CR.42 Falco («Сокол») – одноместный истребитель-биплан, основной истребитель Regia Aeronautica (ВВС Италии) в начальный период Второй мировой войны.

Самолет был разработан конструкторским бюро Fiat под руководством Челестино Розателли. Серийное производство велось с февраля 1939 по июнь 1944 года на заводе Fiat в Турине. Всего было выпущено 1782 самолета.

### Тактико-технические характеристики CR. 42 Falco

Длина, м	8,25
Размах крыла, м	9,7
Взлетный вес, кг	2295
Двигатель	Fiat A.74, 840 л.с.
Максимальная скорость, км/ч	441
Потолок, м	10210
Дальность, км	780
Вооружение	2 12,7-мм пулемета Breda-SAFAT

## CR. 42 Falco WWII Italian Fighter

Fiat CR.42 Falco ("Falcon") – a single-seat biplane fighter, was the main Regia Aeronautica (Italian Air Force) fighter in the initial period of World War II.

The aircraft was developed by the Fiat design office under the direction of Celestino Rosatelli. Serial production was carried out from February 1939 to June 1944 at the Fiat plant in Turin. A total of 1,782 aircraft were produced.

### Tactical and Technical Specifications of CR. 42 Falco

Length, m	8,25
Wingspan, m	9,7
Start Weight, kg	2295
Engine	Fiat A.74, 840 hp
Max. Speed, km/h	441
Service Ceiling, m	10210
Range, km	780
Armament	2 12,7 mm Breda-SAFAT machine guns

## ИСПОЛЬЗУЕМЫЕ КРАСКИ / USED COLORS:

	COLOR	Revell	Tamiya
A	Черный, матовый   Flat Black	108	XF1
B	Белый, матовый   Flat White	105	XF2
C	Темно-зеленый, матовый   Dark Green	168	XF61
D	Коричневый, матовый   Dark Earth	182	XF52
E	Алюминий   Aluminium	199	XF16
F	Сталь   Steel	191	X32
G	Темная сталь   Gun Metal	109	X10
H	Светло-серый   Light Grey	176	XF66

	COLOR	Revell	Tamiya
J	Красный, прозрачный   Clear Red	731	X27
K	Зеленый, прозрачный   Clear Green	161	X25
L	Ржавчина   Rust	137	X34
M	Желтый, матовый   Flat Yellow	115	XF3
N	Красно-коричневый, матовый   Red Brown	185	XF64
P	Песочный, матовый   Desert Yellow	116	XF59
R	Красный, матовый   Flat Red	136	XF7

### 01 СТАДИЯ СБОРКИ ASSEMBLY STEP

### 03 СБОРОЧНАЯ ЕДИНИЦА ASSEMBLY UNIT

### ПРИ СБОРКЕ НЕ ИСПОЛЬЗУЕТСЯ PARTS NOT FOR USE

### A ИСПОЛЬЗУЕМАЯ КРАСКА USED COLOR

### ? ПРОИЗВОЛЬНЫЙ ВЫБОР OPTIONAL

### \* СДЕЛАТЬ САМОМУ SCRATCH BUILD

### x2 СДЕЛАТЬ ДВЕ ДЕТАЛИ MAKE 2 PCS

### НЕ КЛЕИТЬ DO NOT CEMENT

### ПРОСВЕРЛИТЬ OPEN HOLE

**ВНИМАНИЕ!**  
Перед сборкой внимательно прочитать руководство по монтажу. Каждая деталь пронумерована. Соблюдать последовательность монтажа. Необходимые рабочие инструменты: нож и напильник для зачистки деталей; резиновая лента, клейкая лента и зажимы для сушки белья для прижимания склеиваемых деталей. Детали из пластика очистить в растворе мягкого моющего средства и высушить на воздухе для того, чтобы краска и переводные картинки лучше прилипали. Перед приклеиванием проверить, подходит ли детали; клей наносить экономно. Хром и краску удалить с поверхностей склеивания. Небольшие детали покрасить перед тем, как они будут удалены из рамок. Краску необходимо хорошо просушить, только после этого продолжать сборку. Каждую соответствующую переводную картинку отдельно вырезать и примерно на 20 секунд окунуть в теплую воду. На обозначенном месте картинку отделить от бумаги и прижать промокательной бумагой.

**CAUTION!**  
Read the instructions thoroughly prior to assembly. Each component is numbered. Adhere to specified sequence of assembly. Tools required: knife and file for removal of components from frame; rubber bond, adhesive tape and clothes pegs for clamping components together after applying adhesive. Clean plastic components in a mild detergent solution and allow to air-dry so that paint and transfers adhere better. Prior to applying adhesive, check to see whether the components fit together; apply adhesive sparingly. Remove chrome and paint from the contact surfaces. Paint small components before removing them from the frame. Allow paint to dry well, and only then continue to assemble. Cut out each transfer individually and immerse in warm water for approx. 20 seconds. Slide transfer off paper and into designated position, then press on with blotting paper.

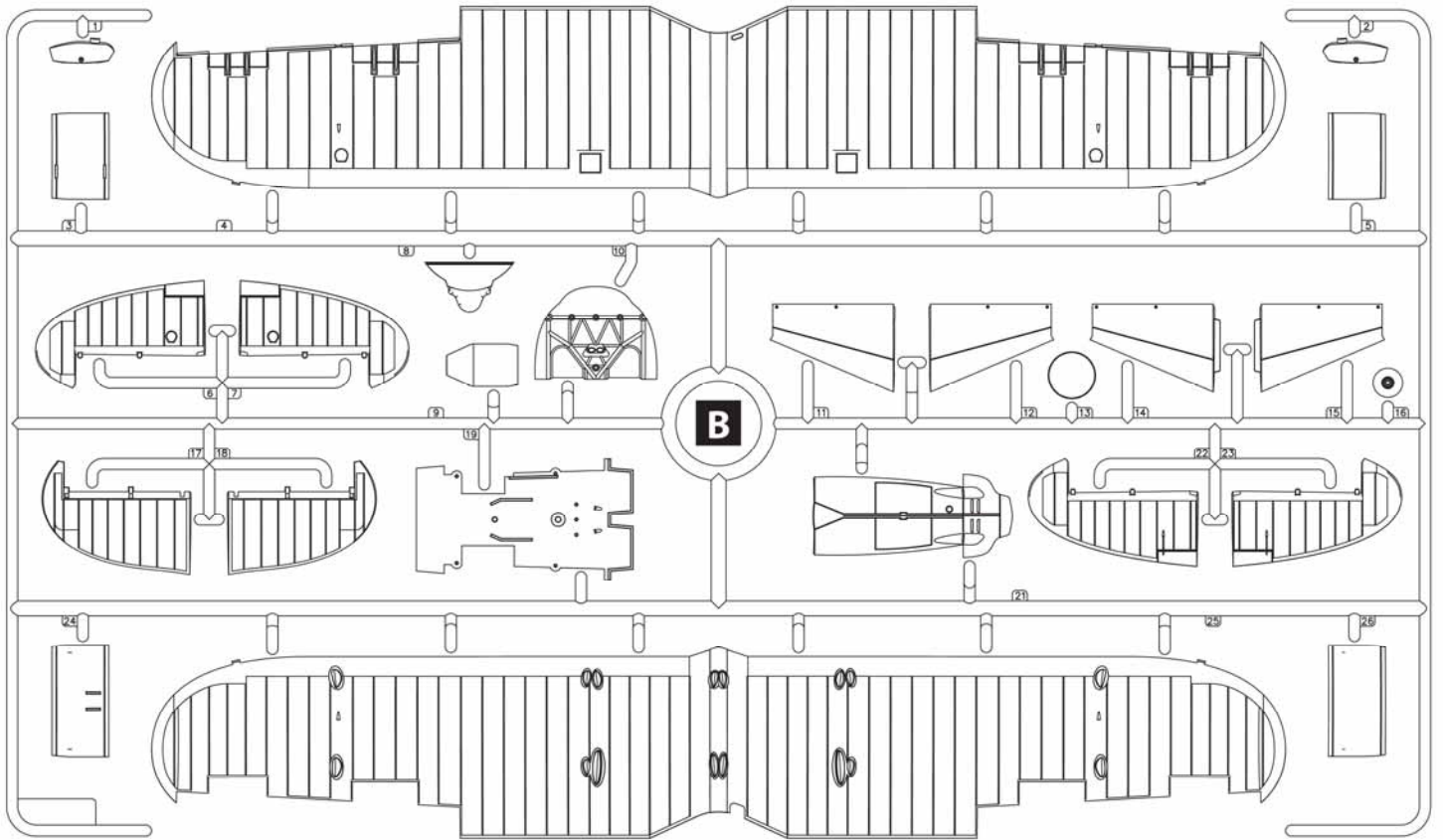
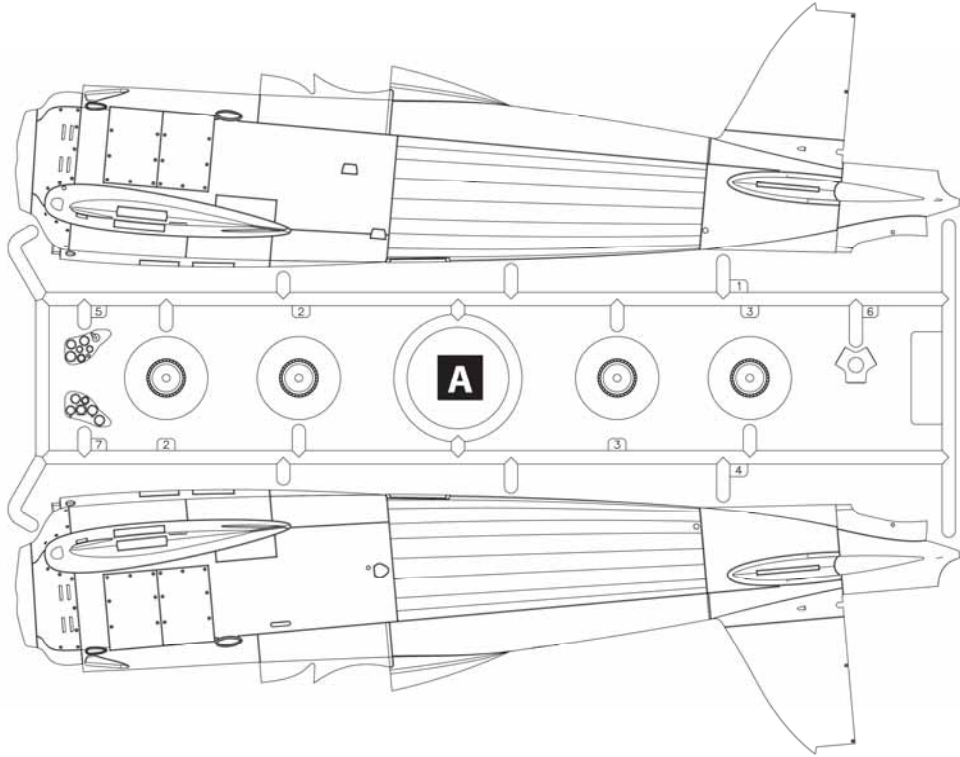

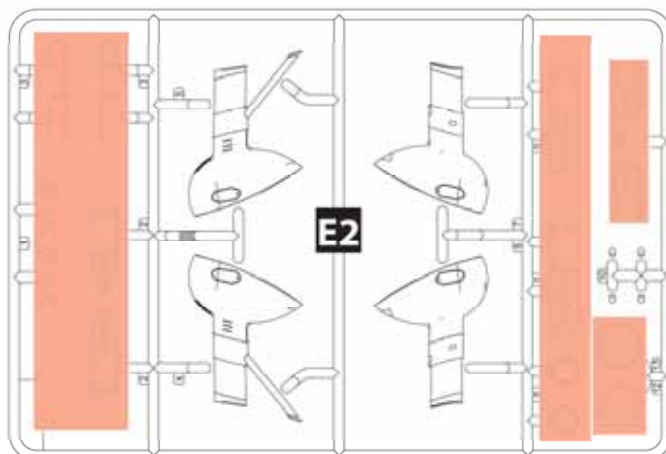
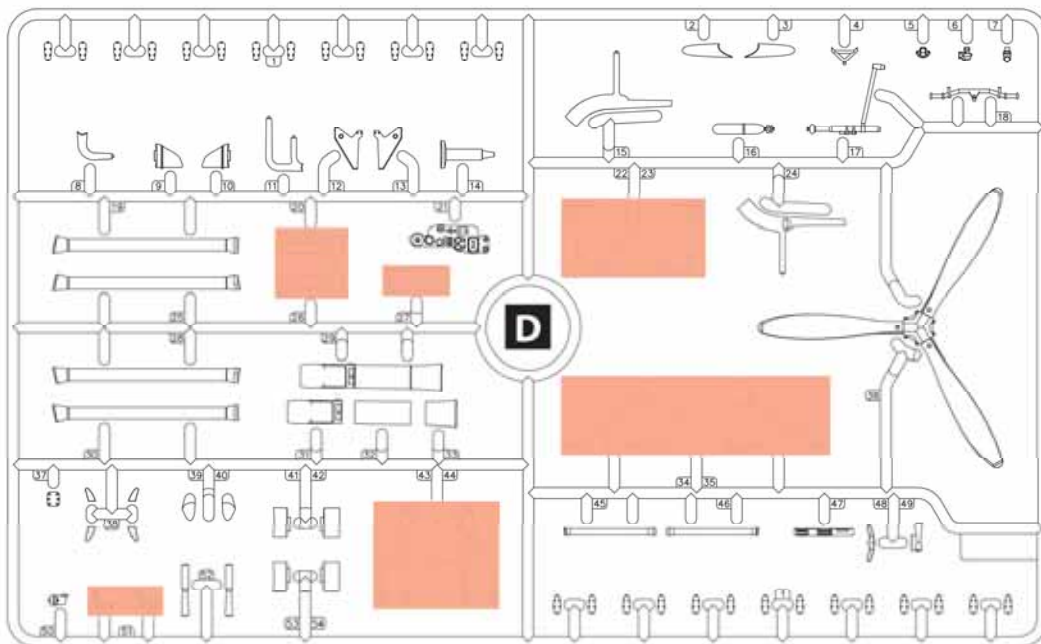
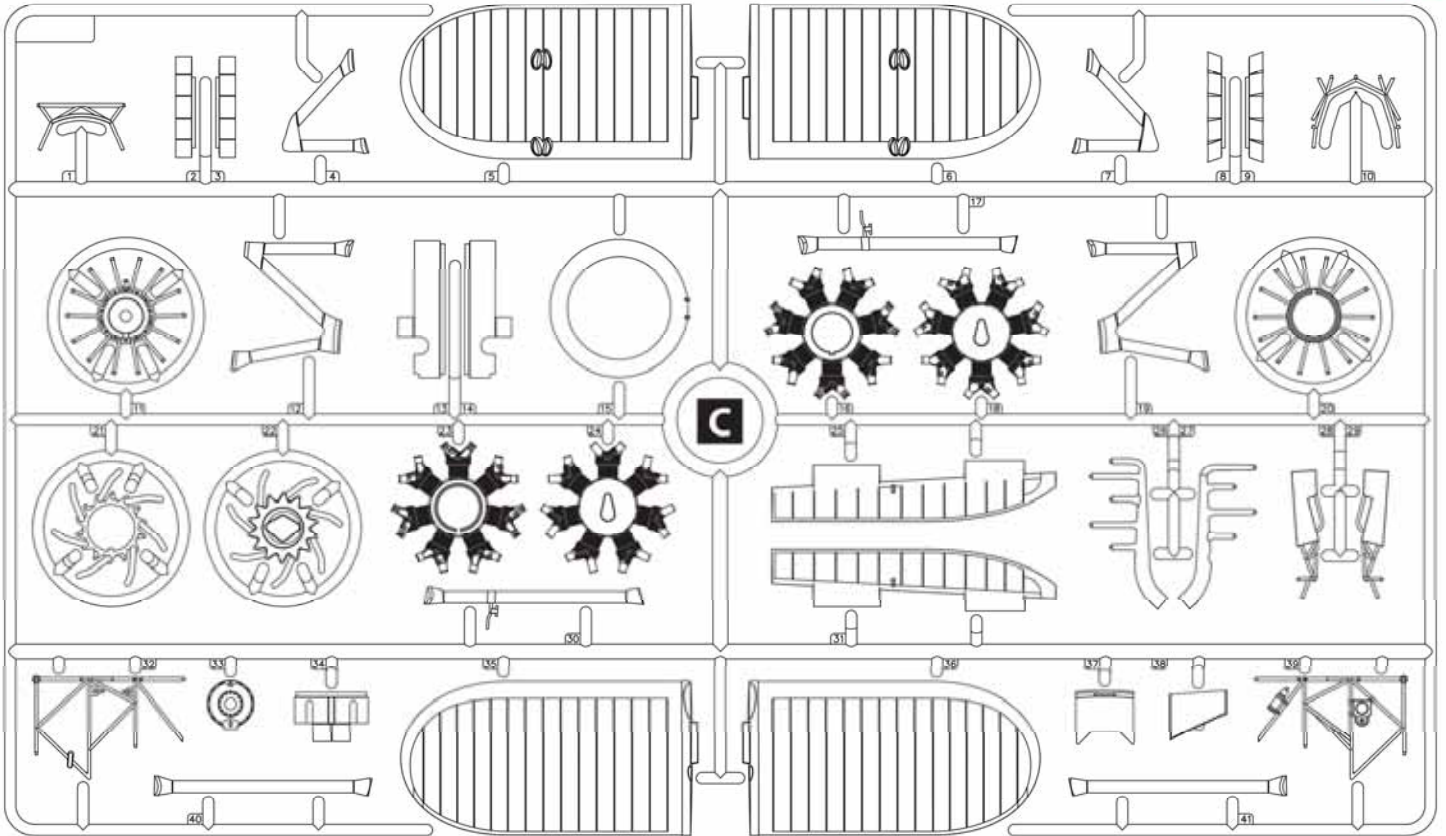

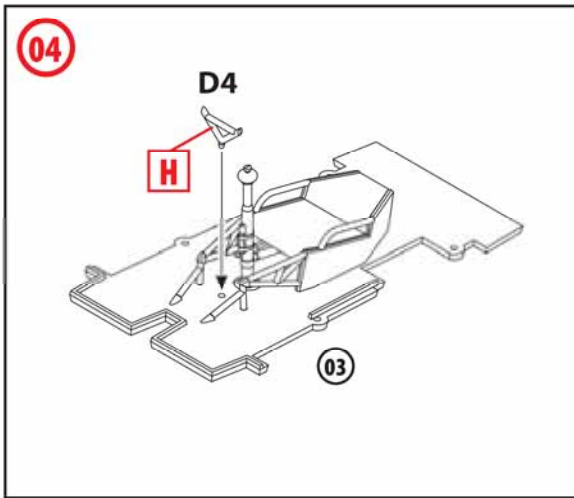
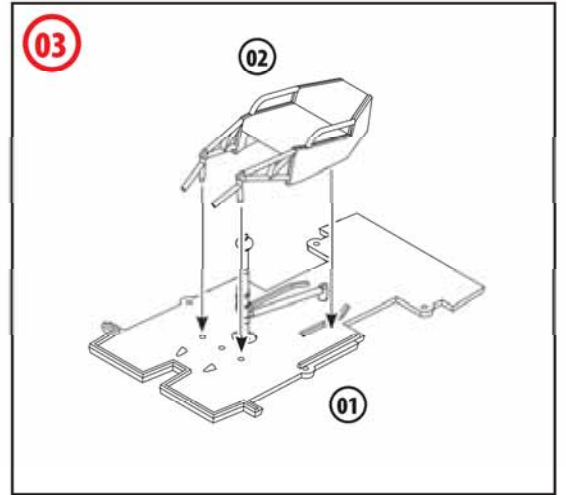
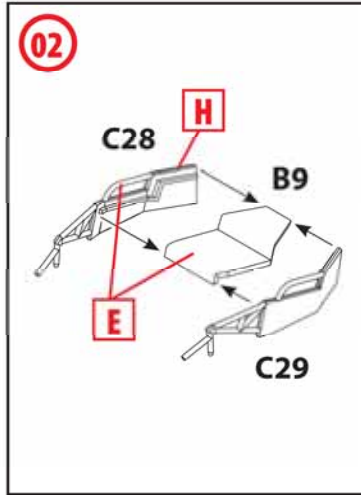
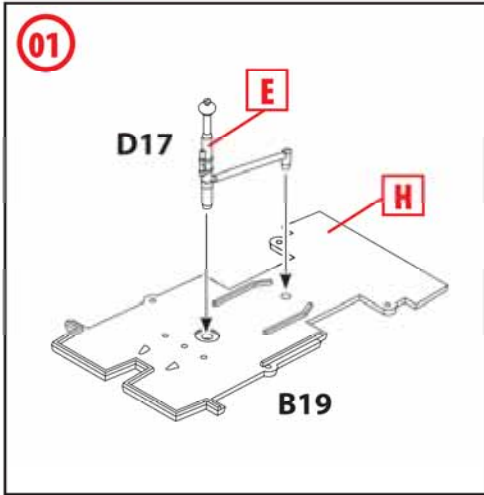

**ВНИМАНИЕ!** Изображения приборов - даны отдельными элементами  
**WARNING!** Instrument images - given by individual elements

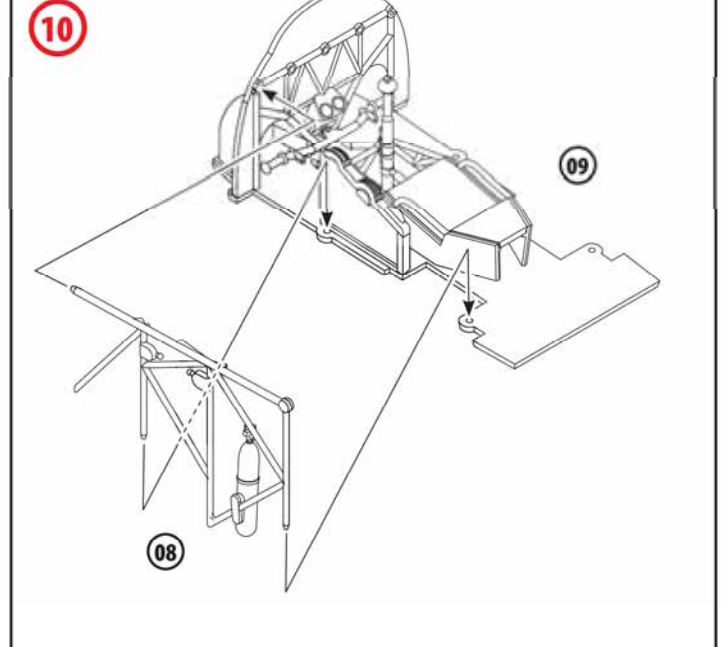
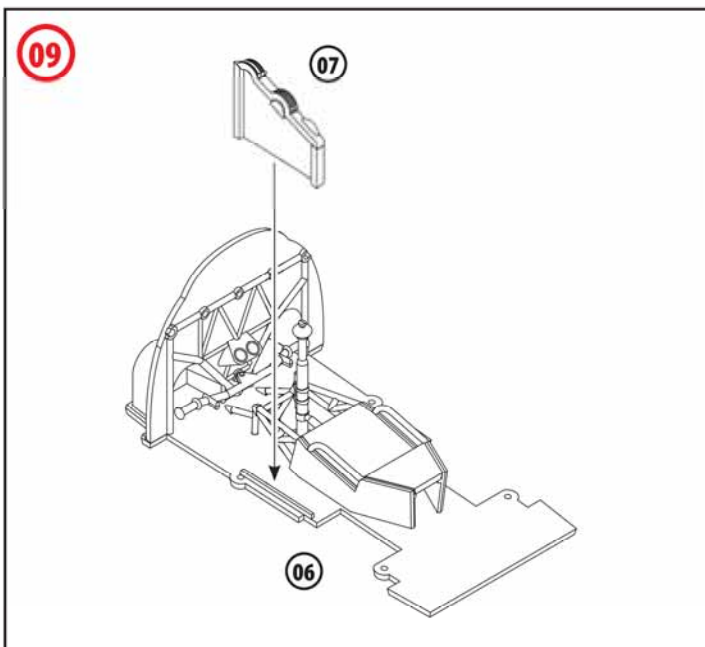
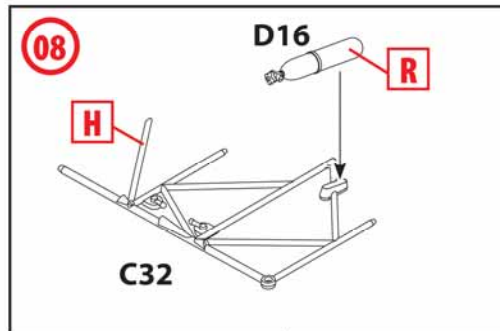
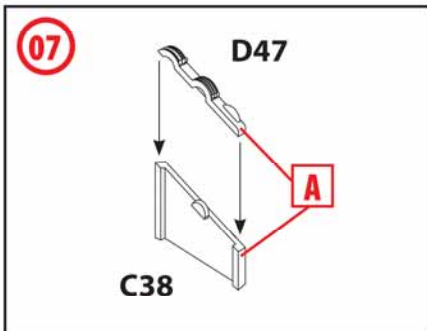
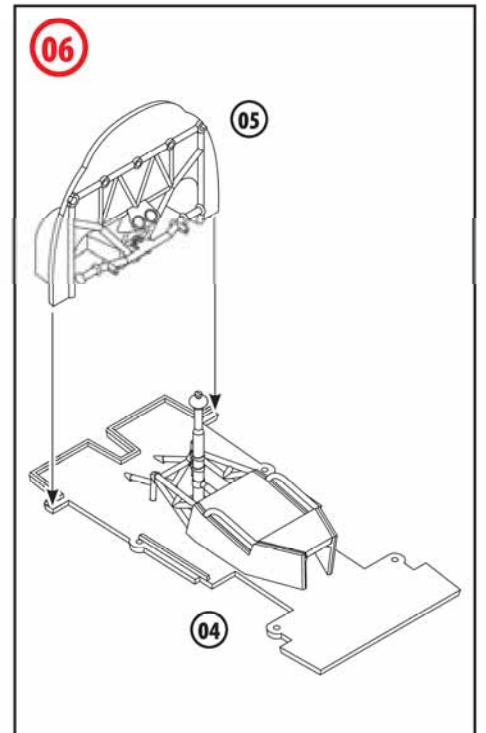

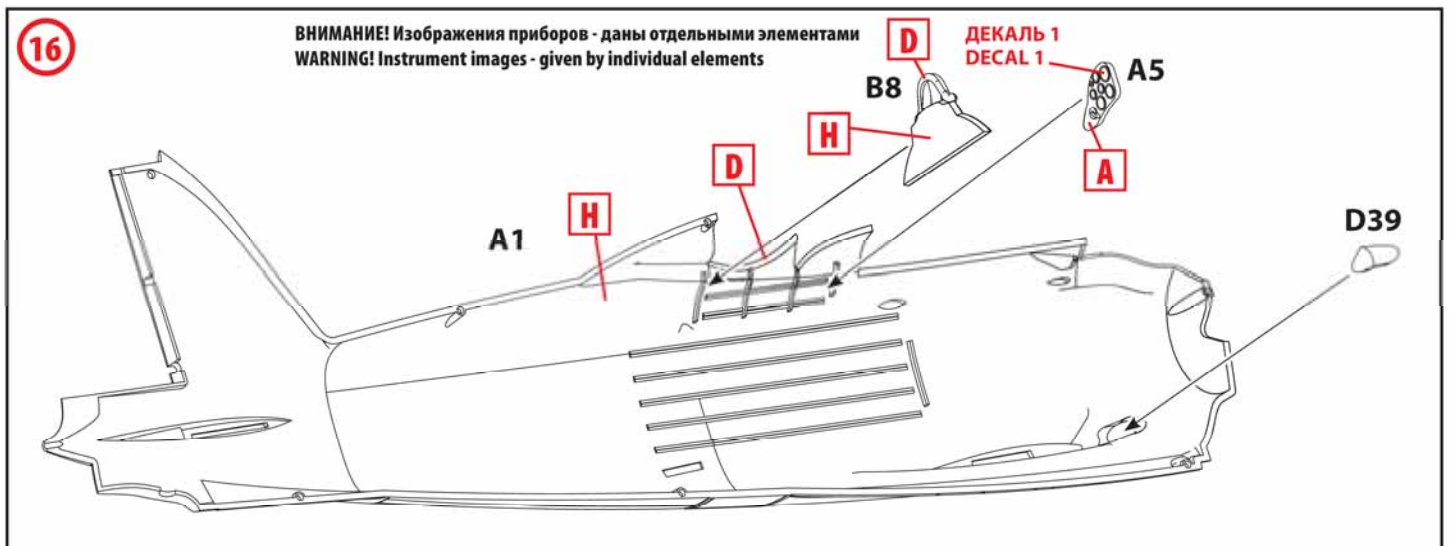
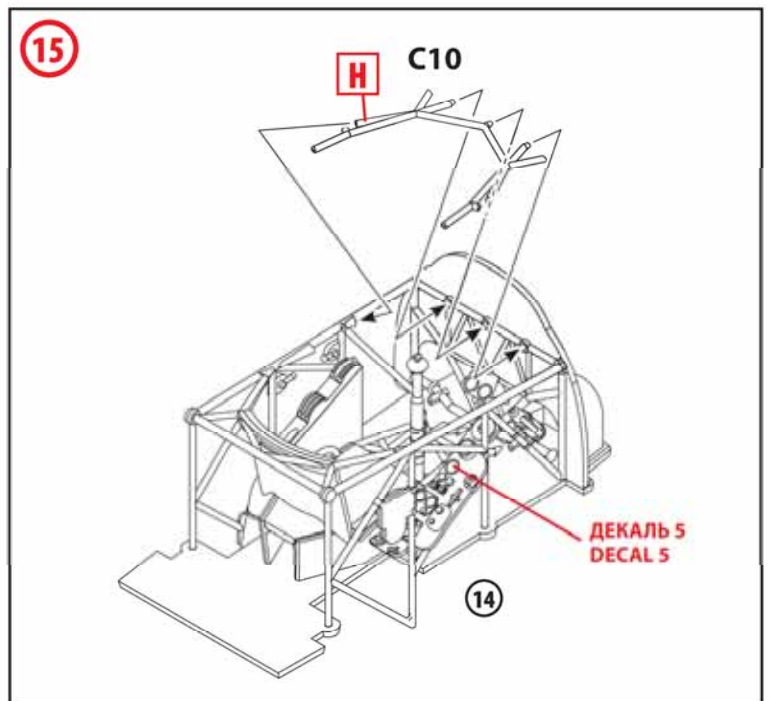
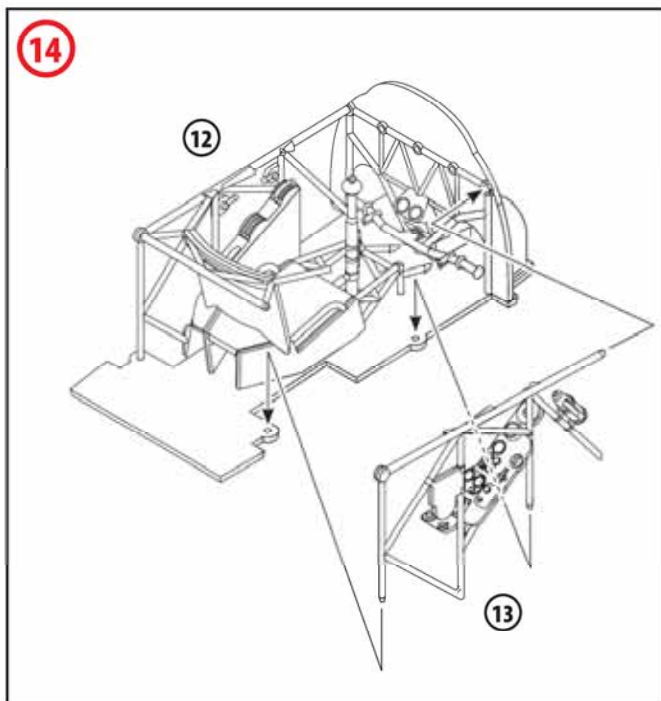
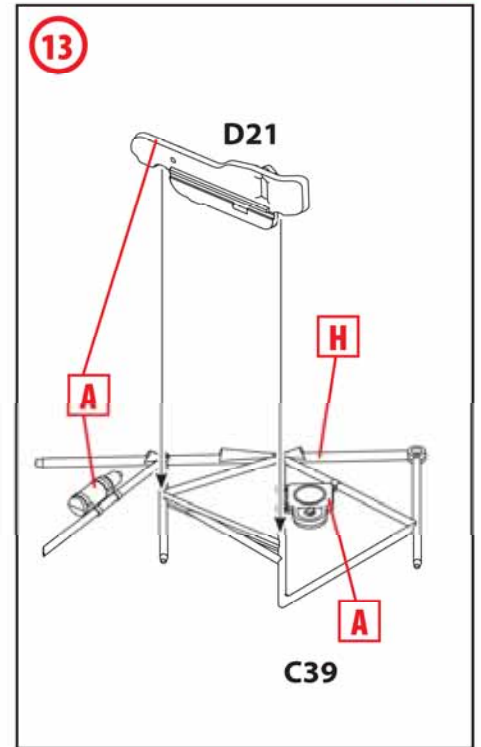
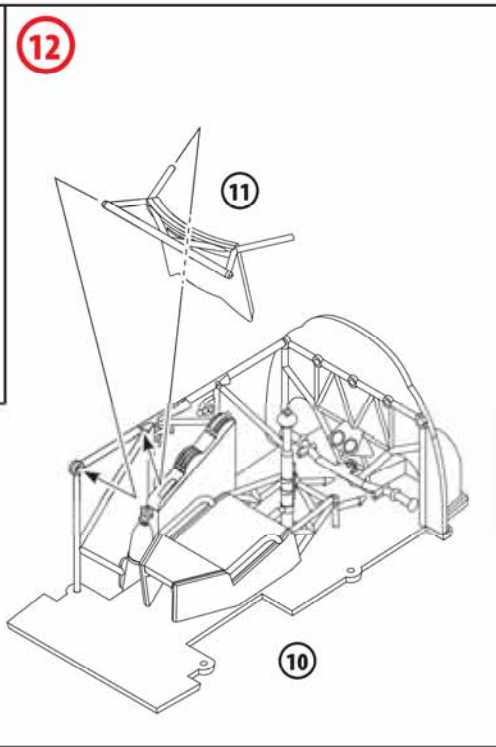
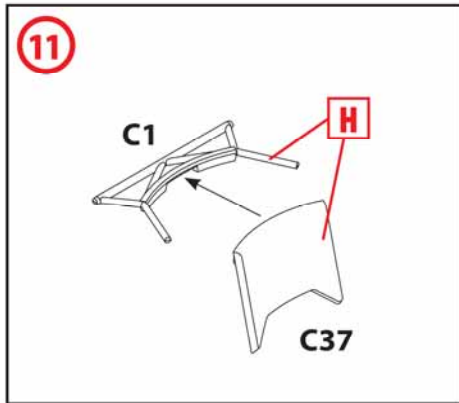

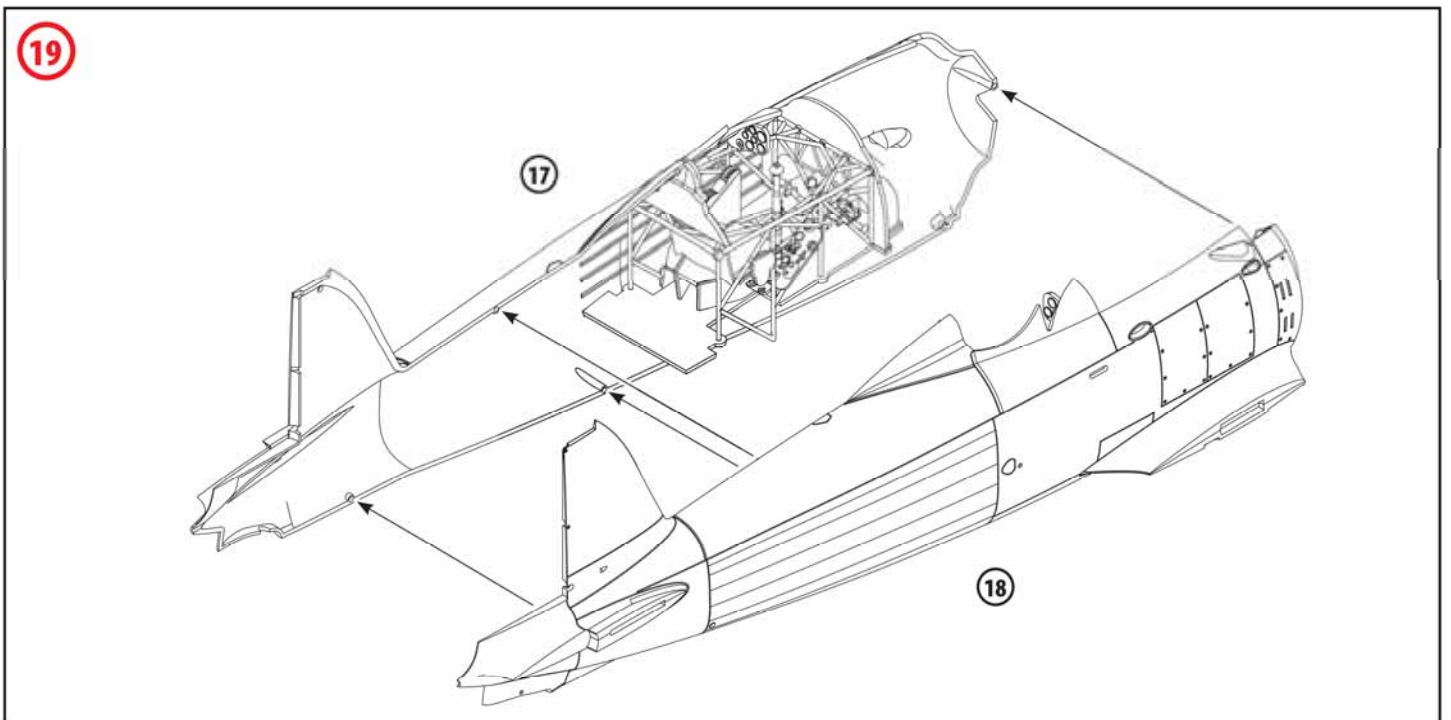
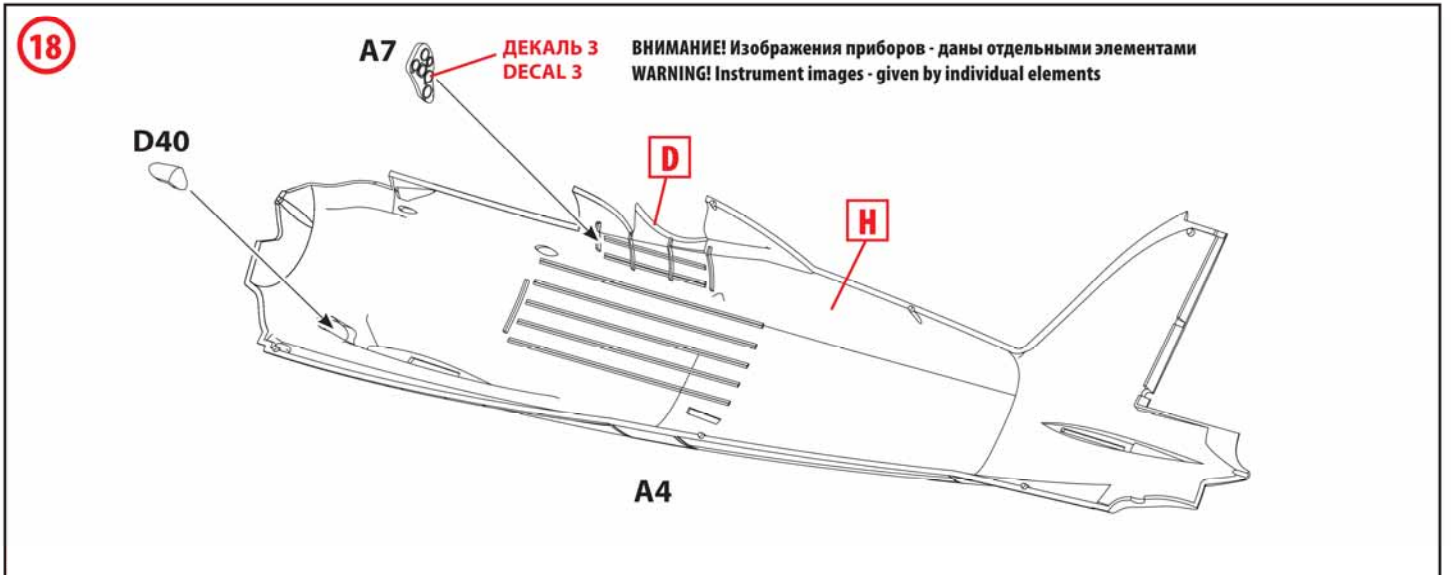
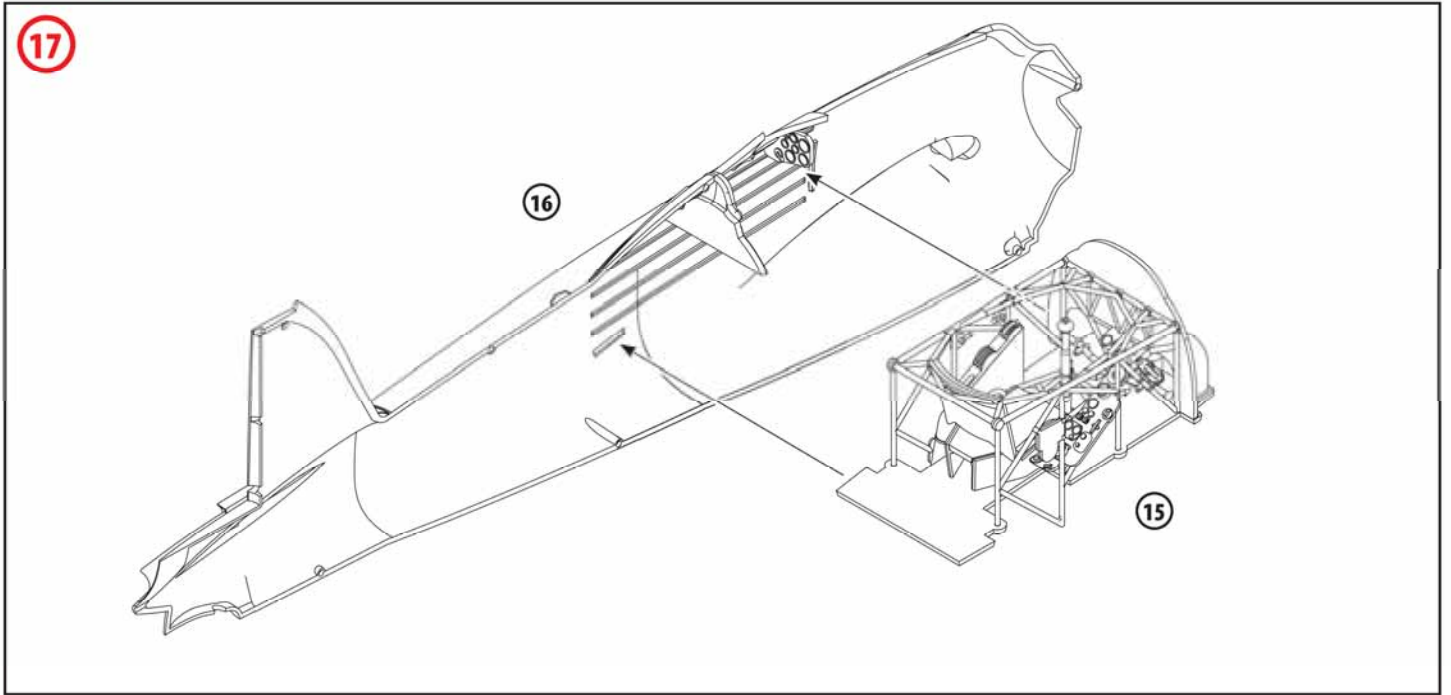

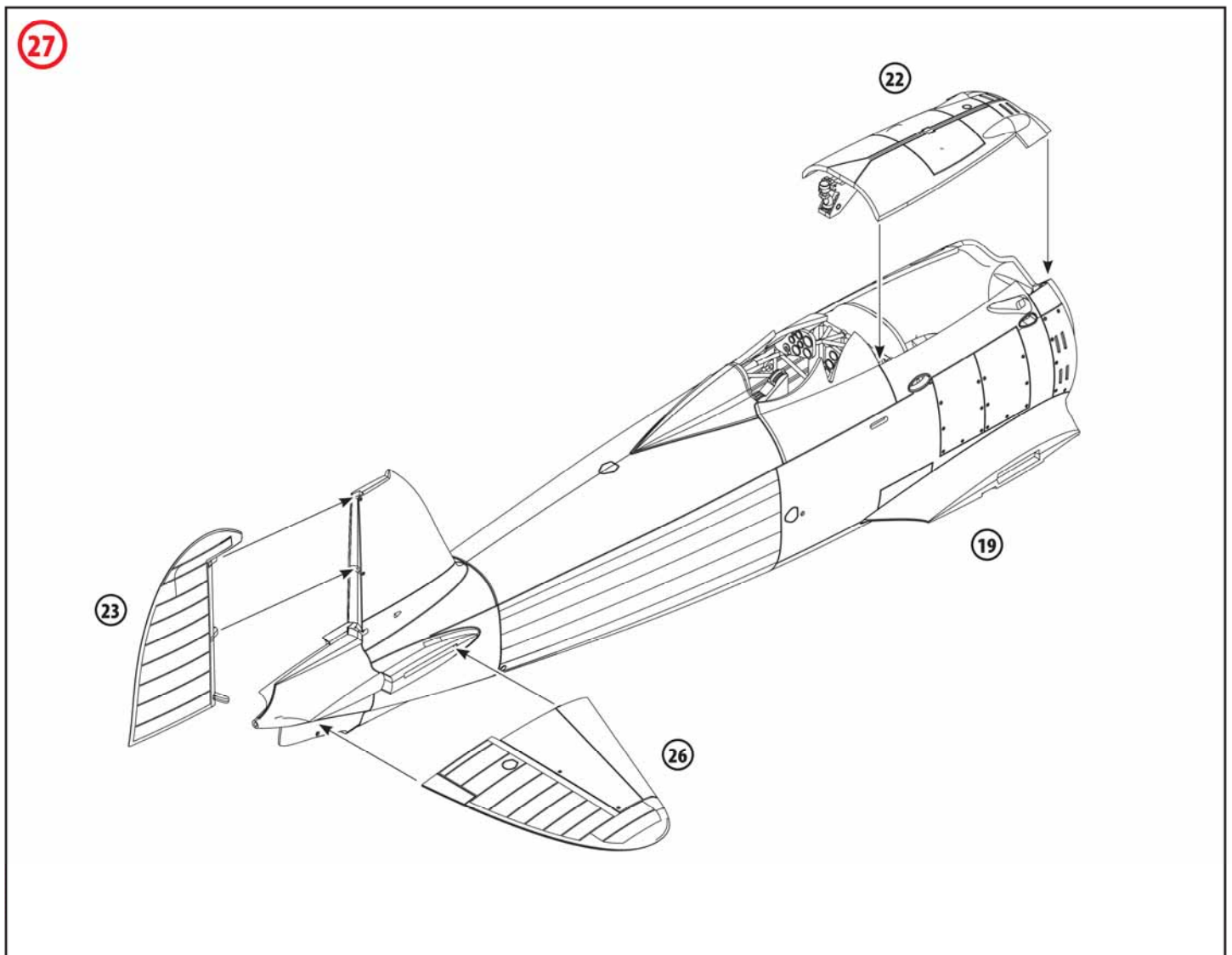
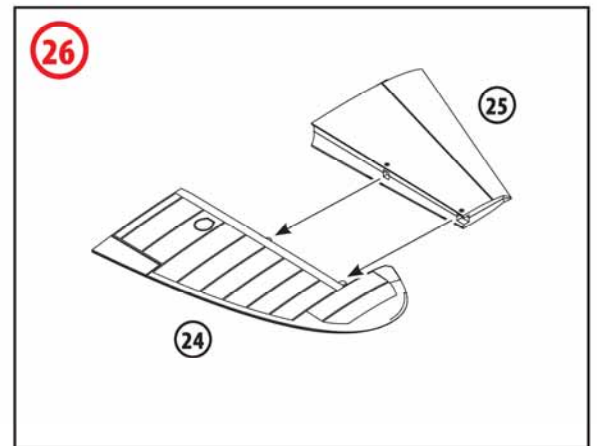
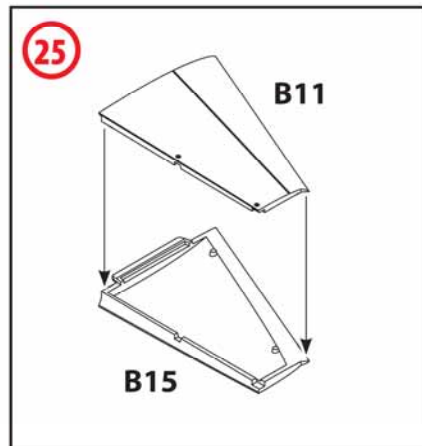
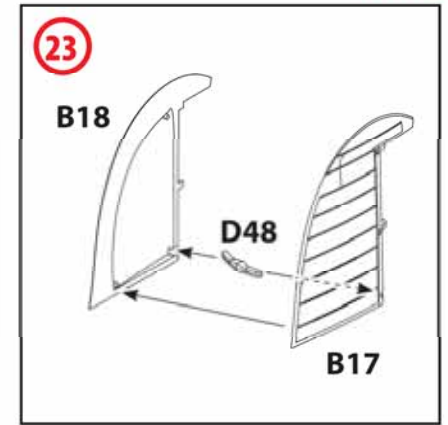
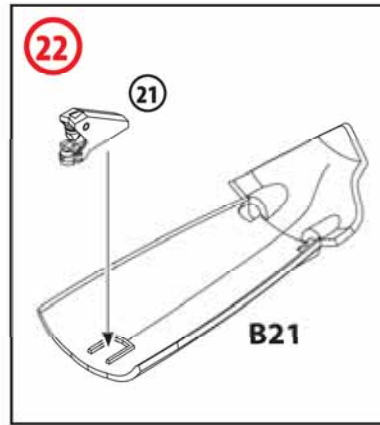
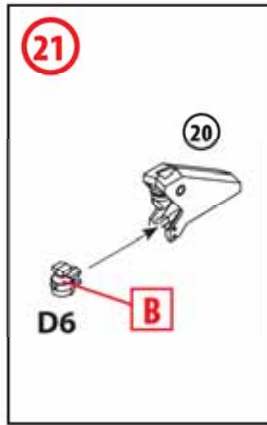
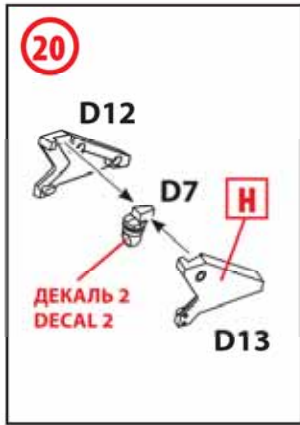

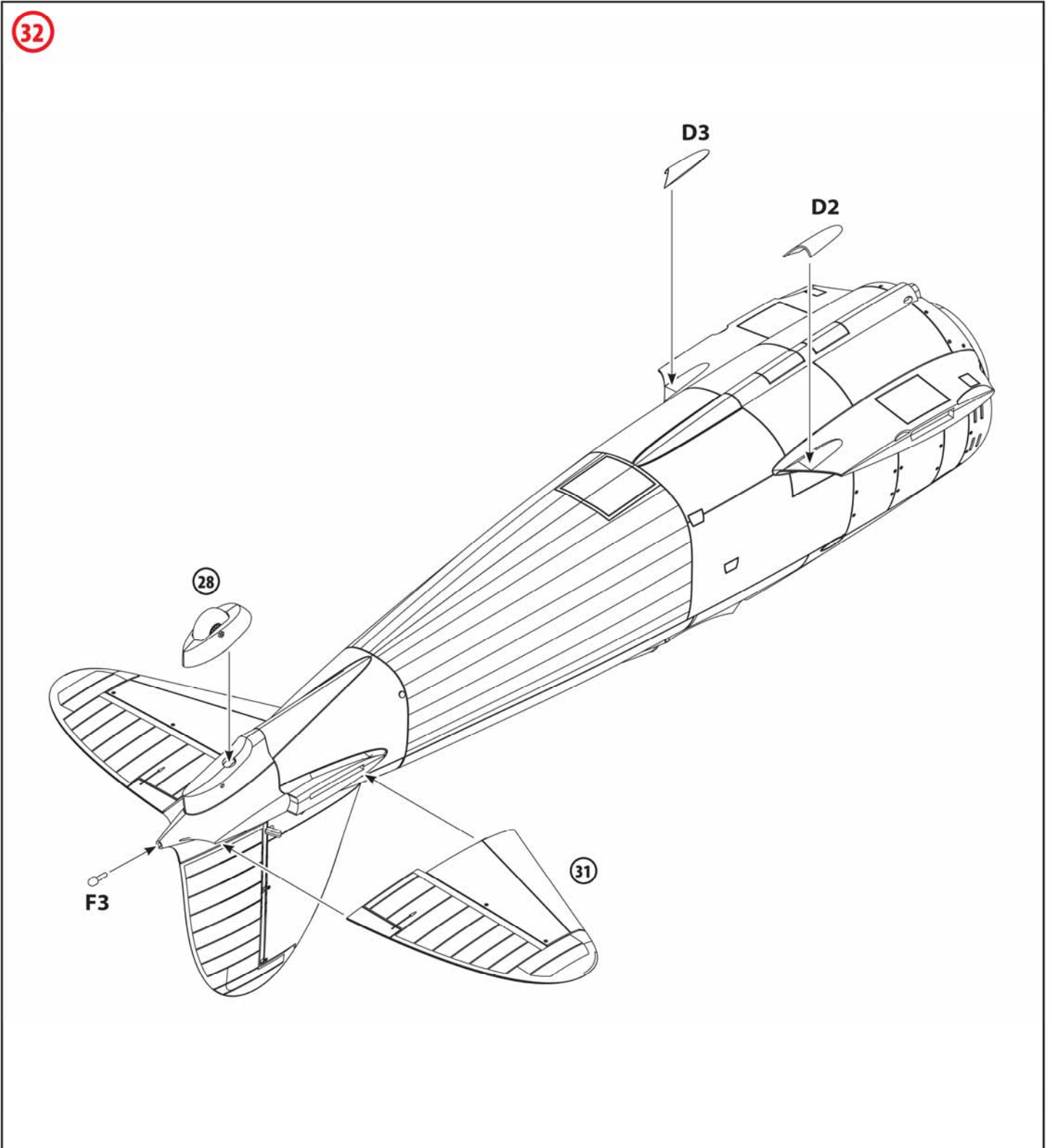
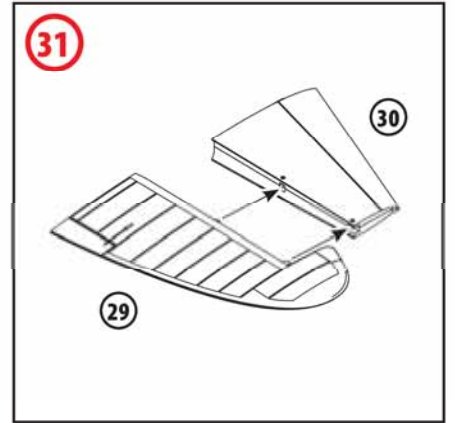
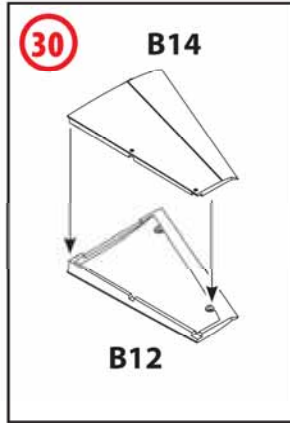
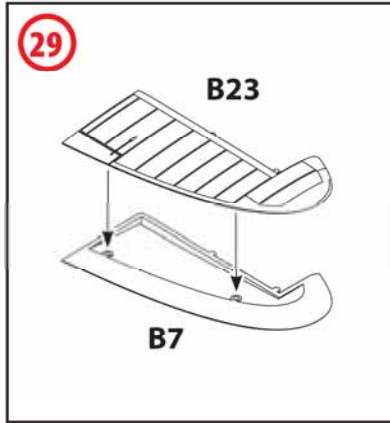
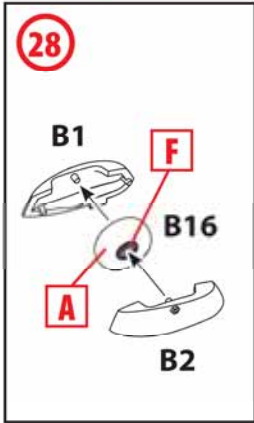



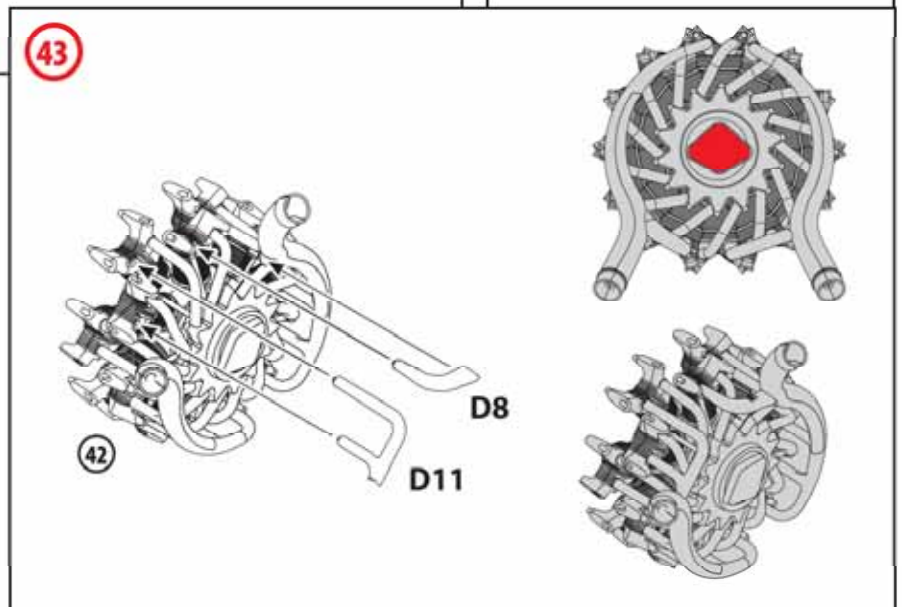
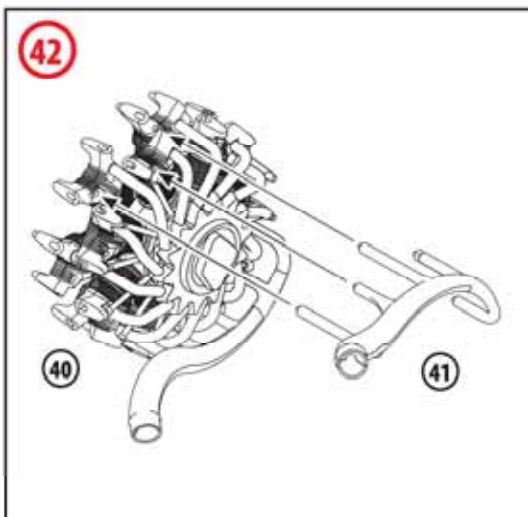
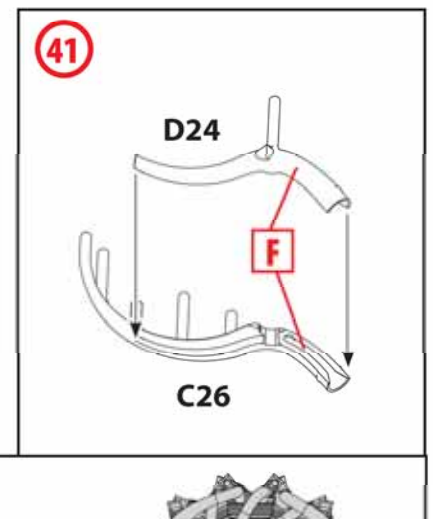
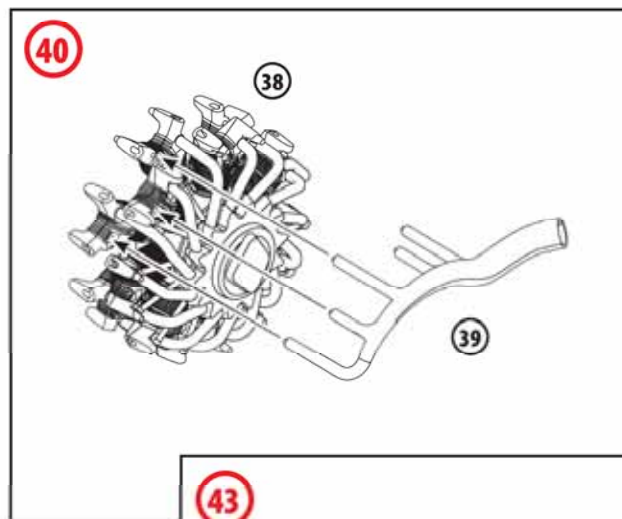
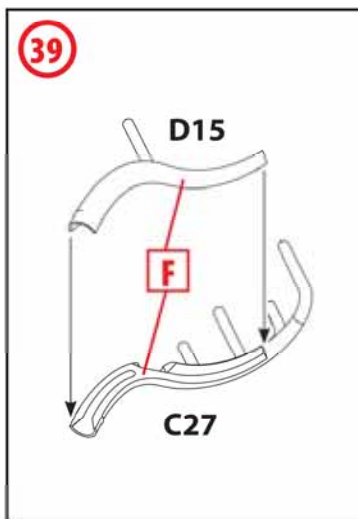
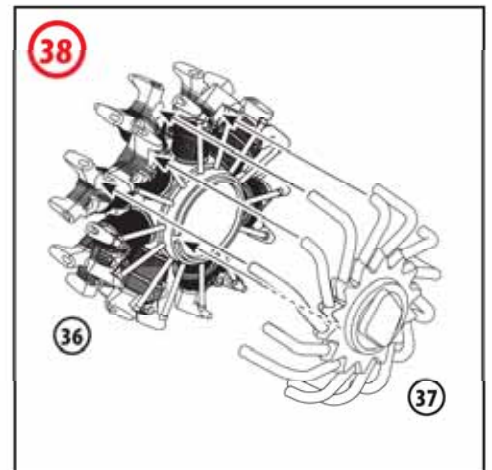
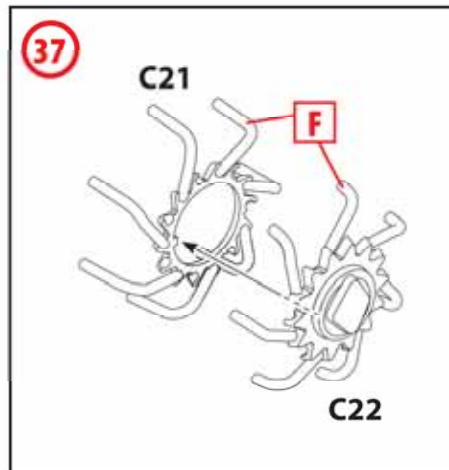
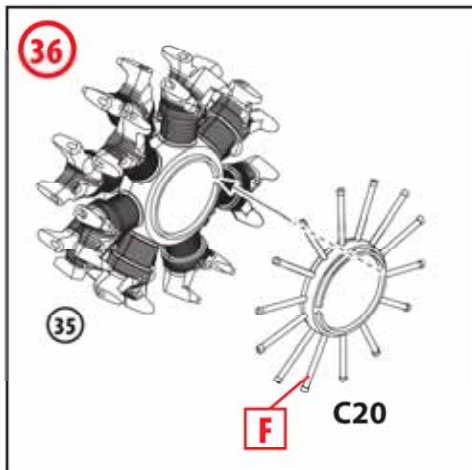
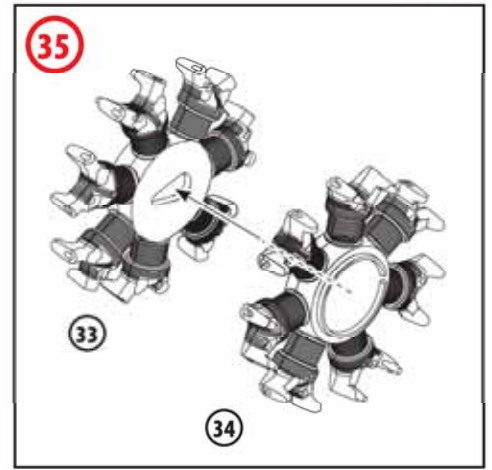
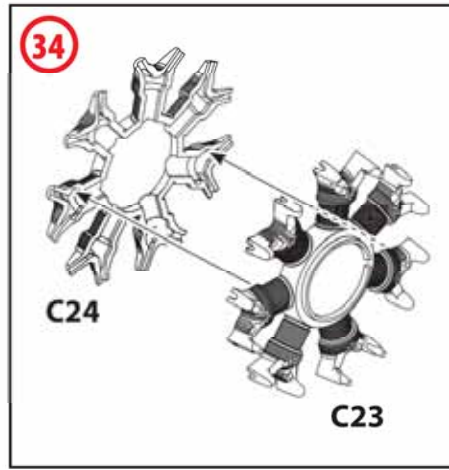
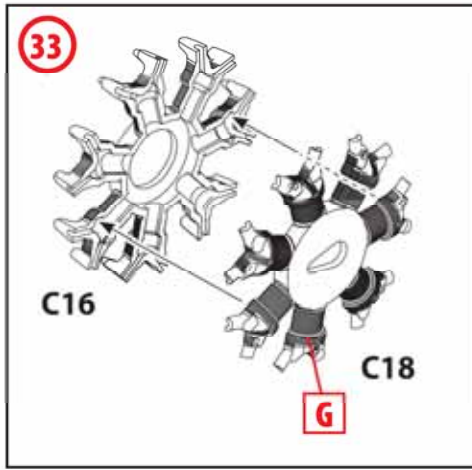

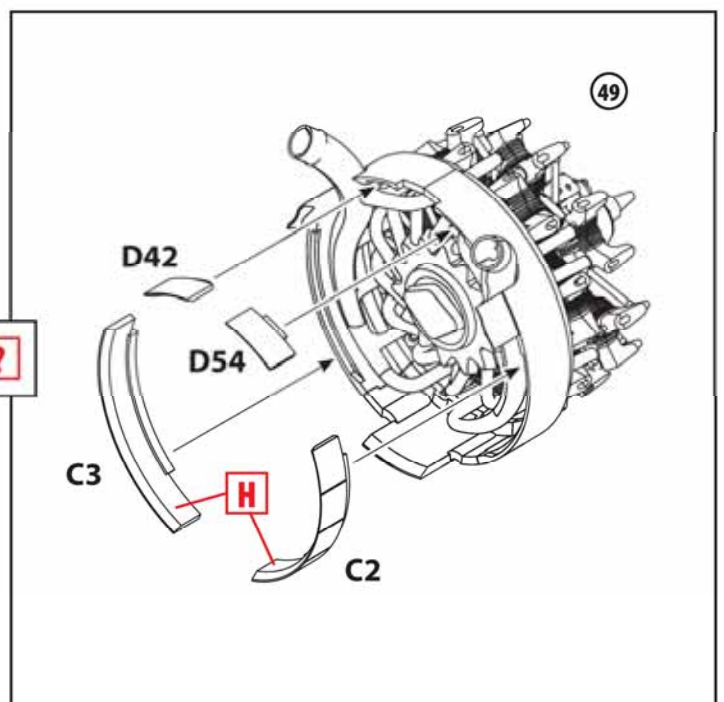
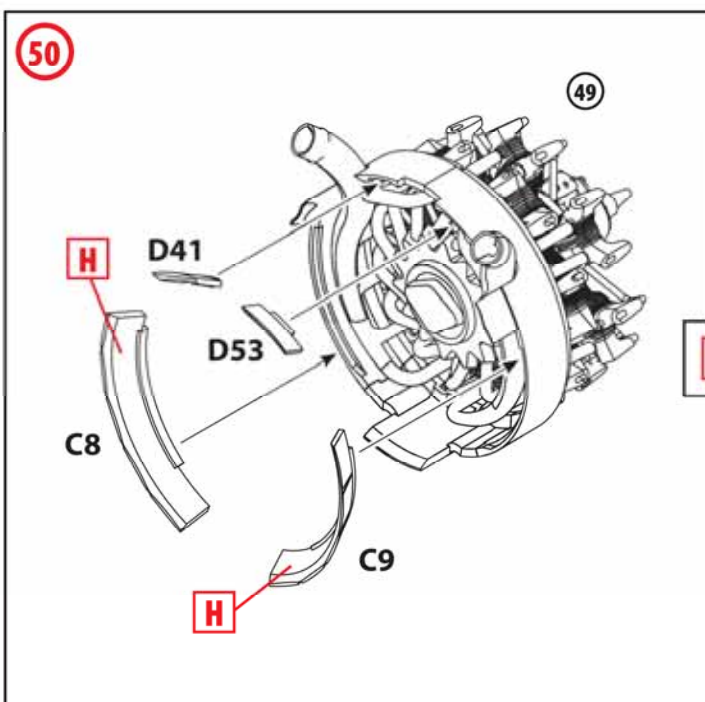
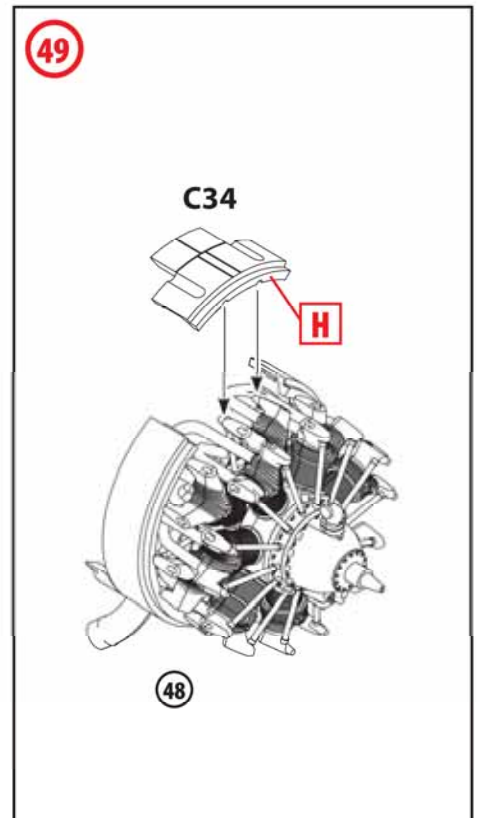
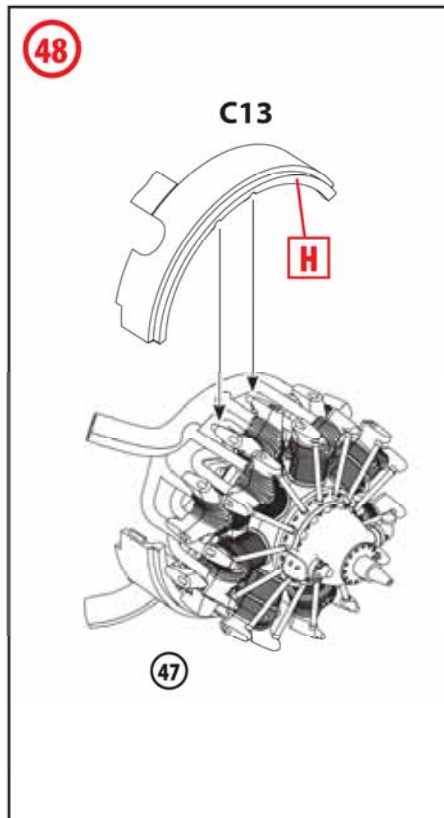
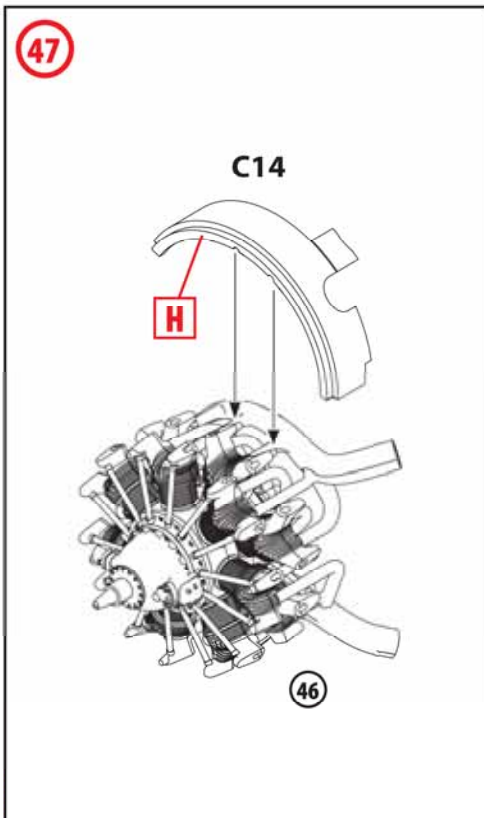
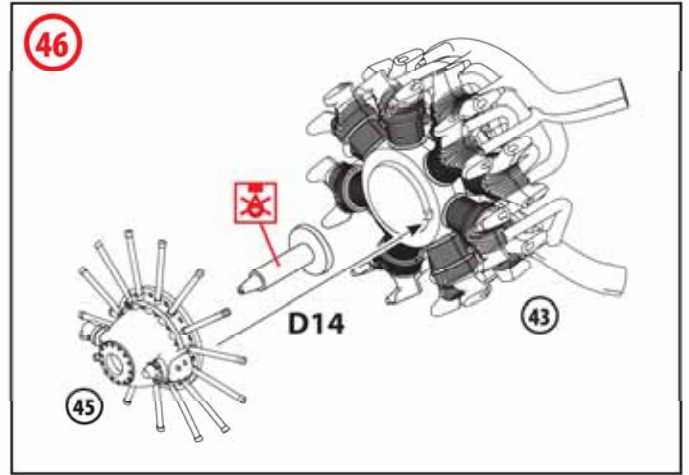
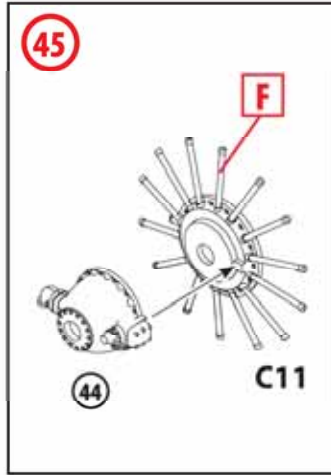
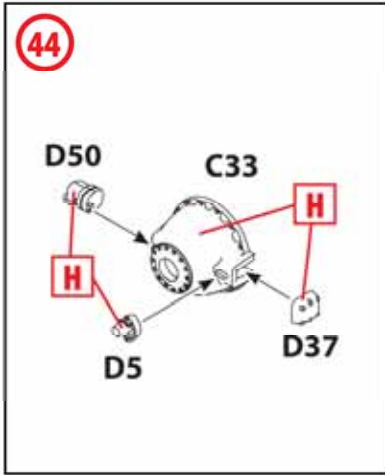

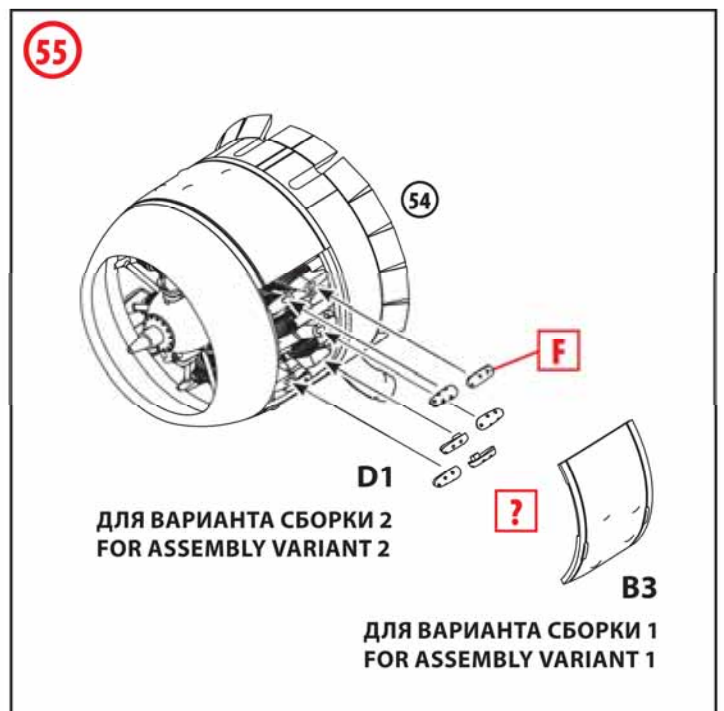
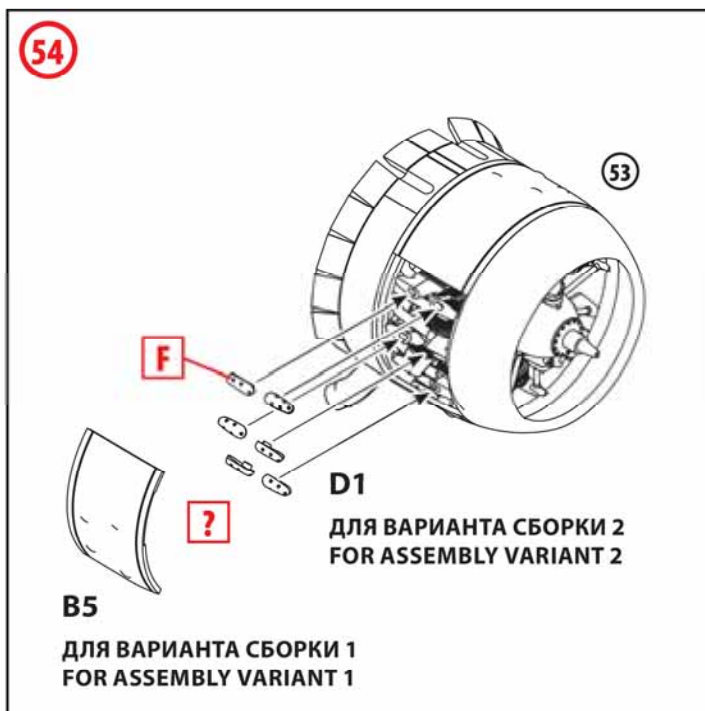
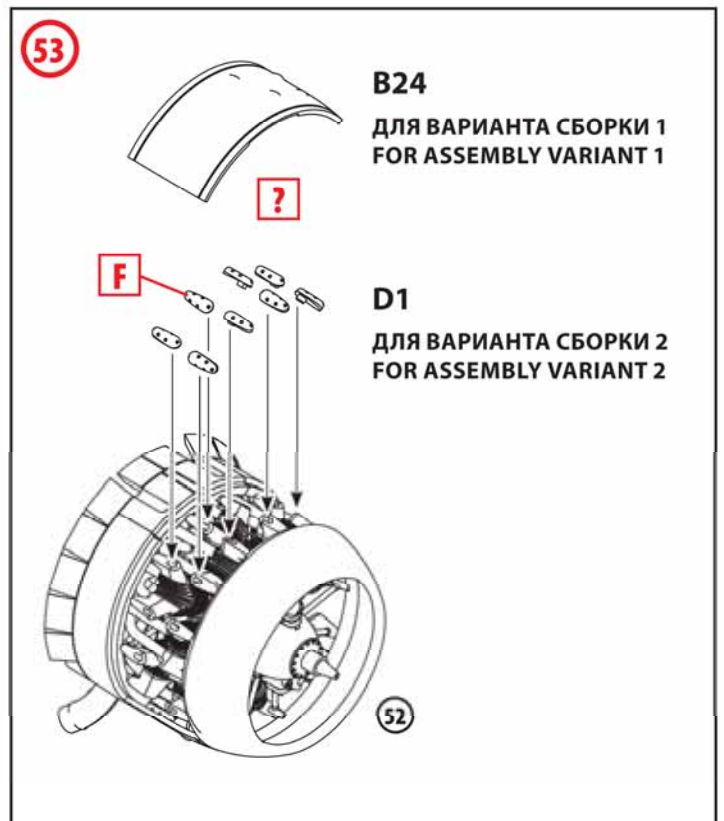
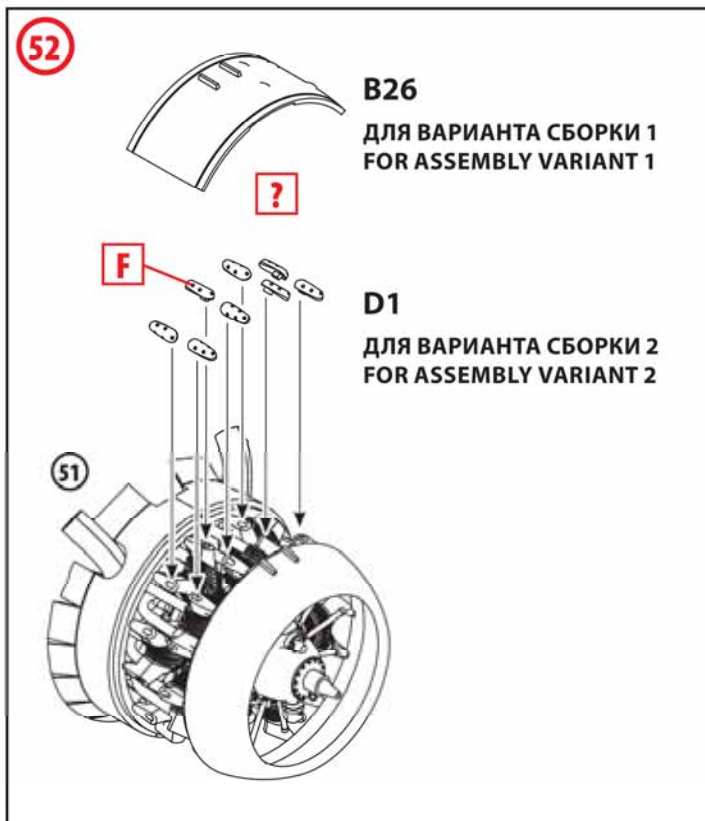
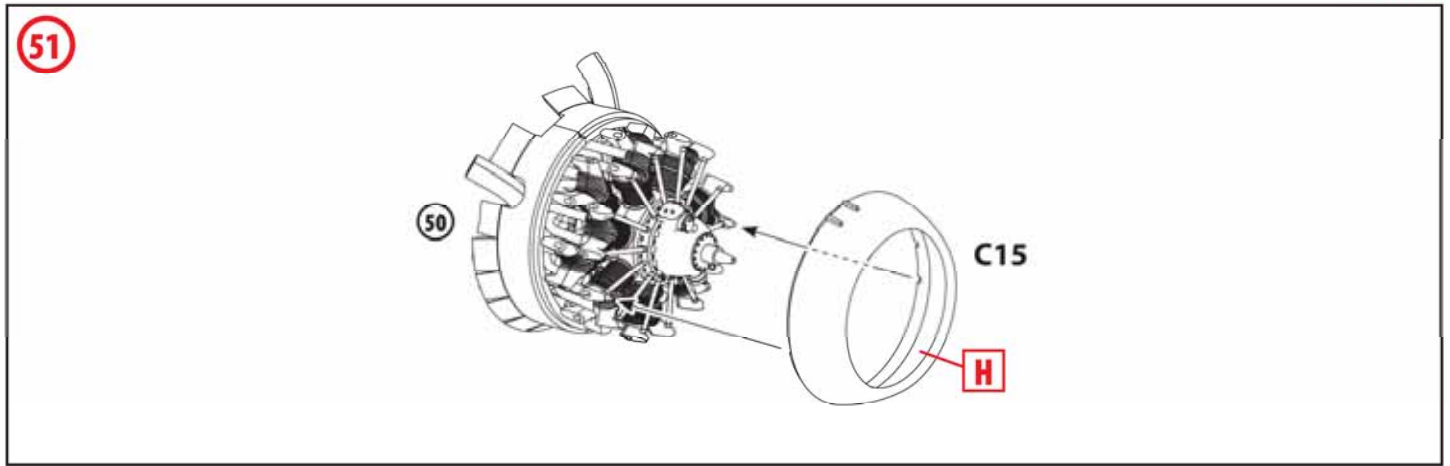

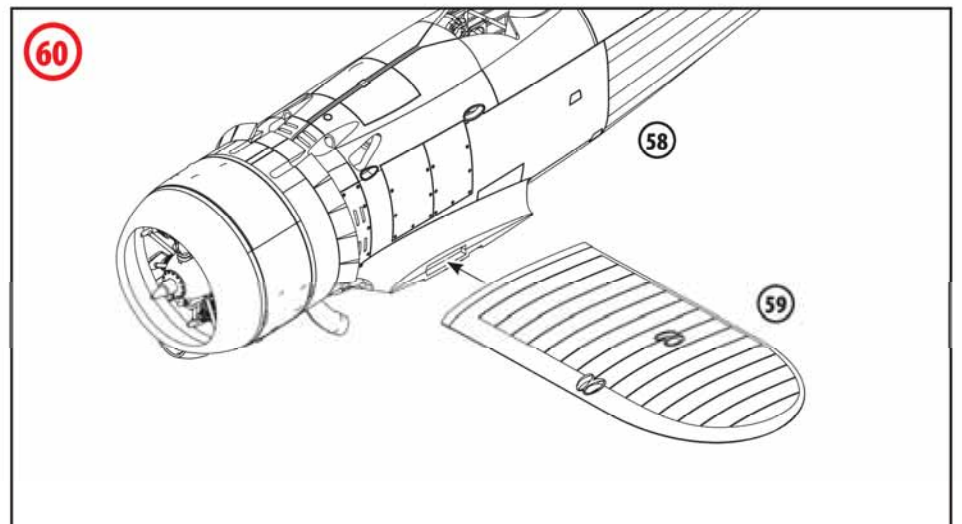
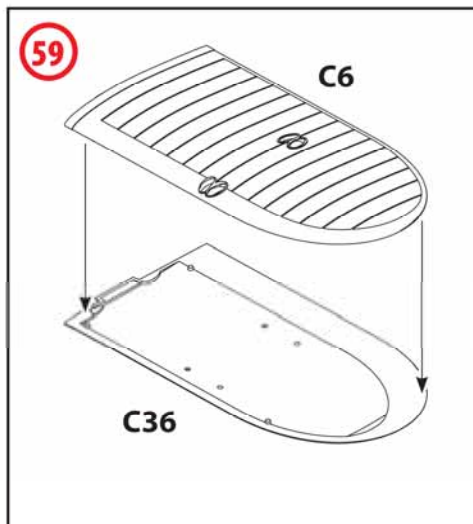
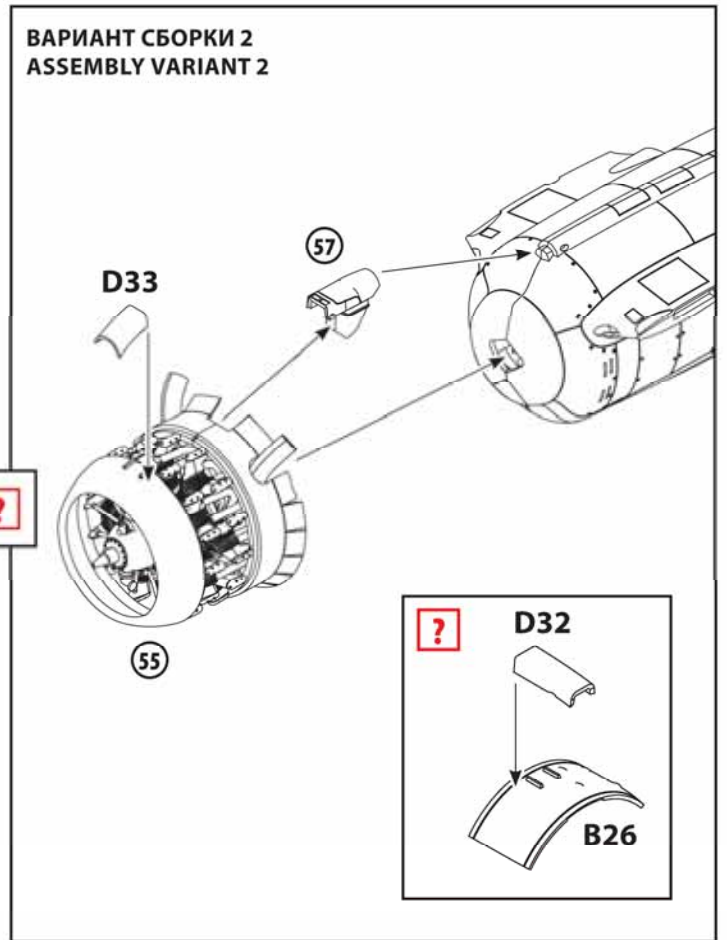
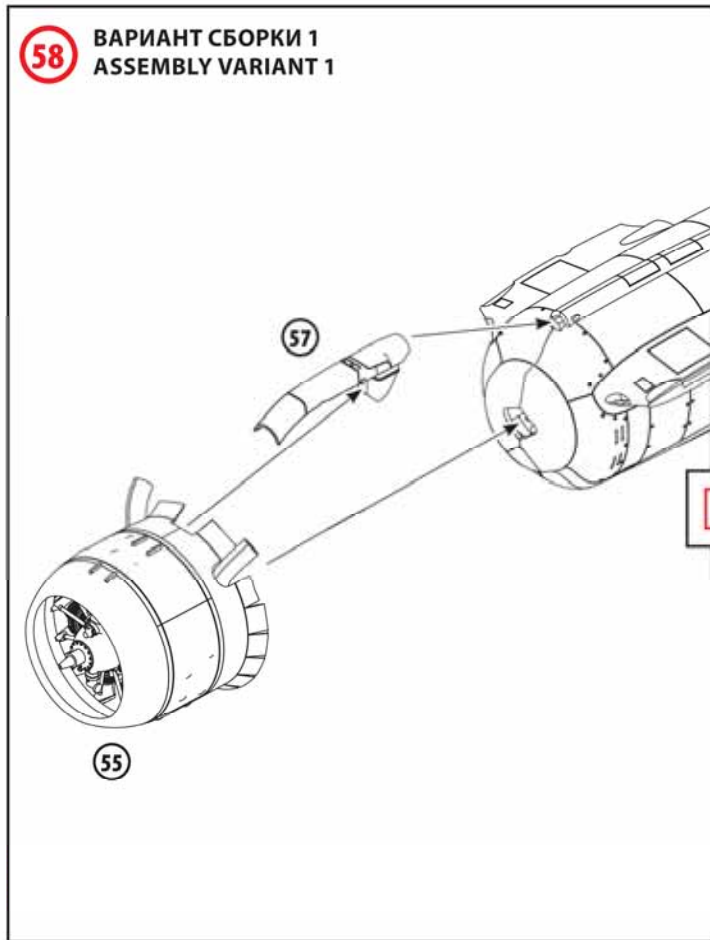
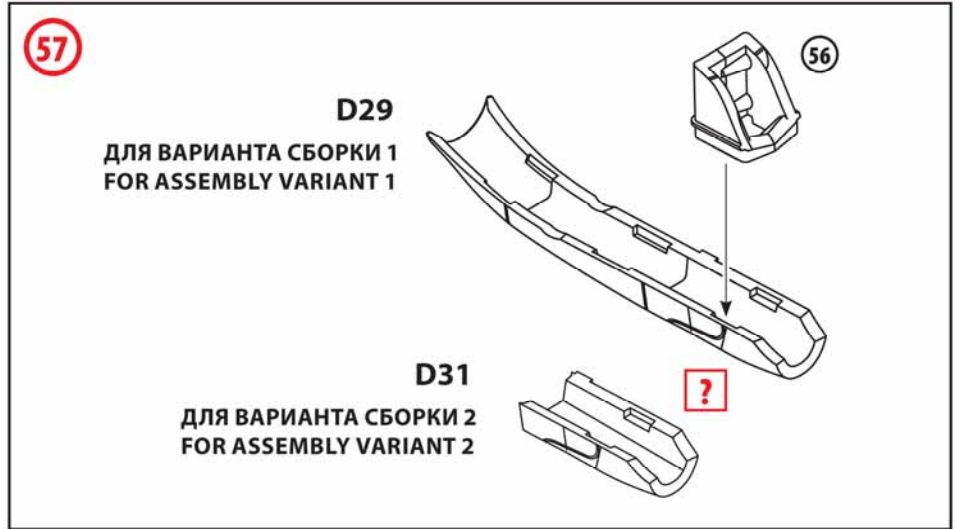
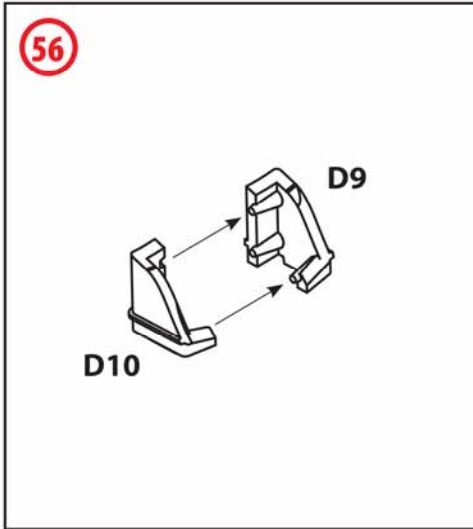

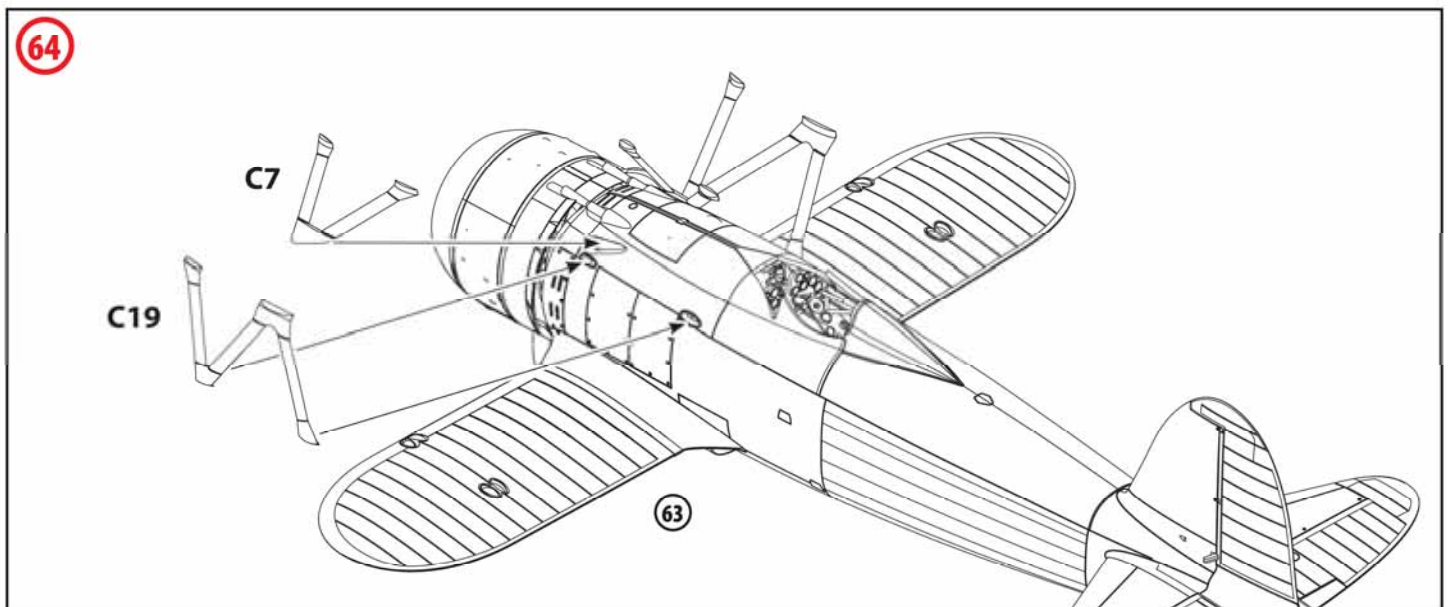
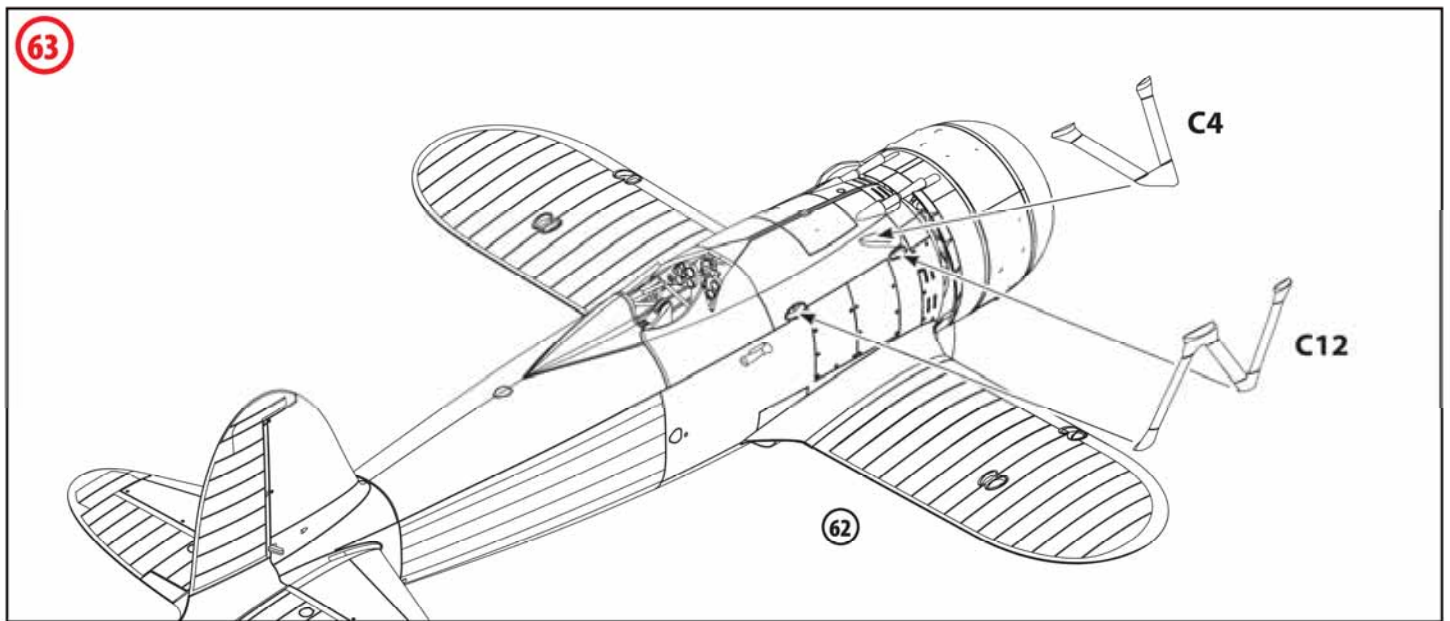
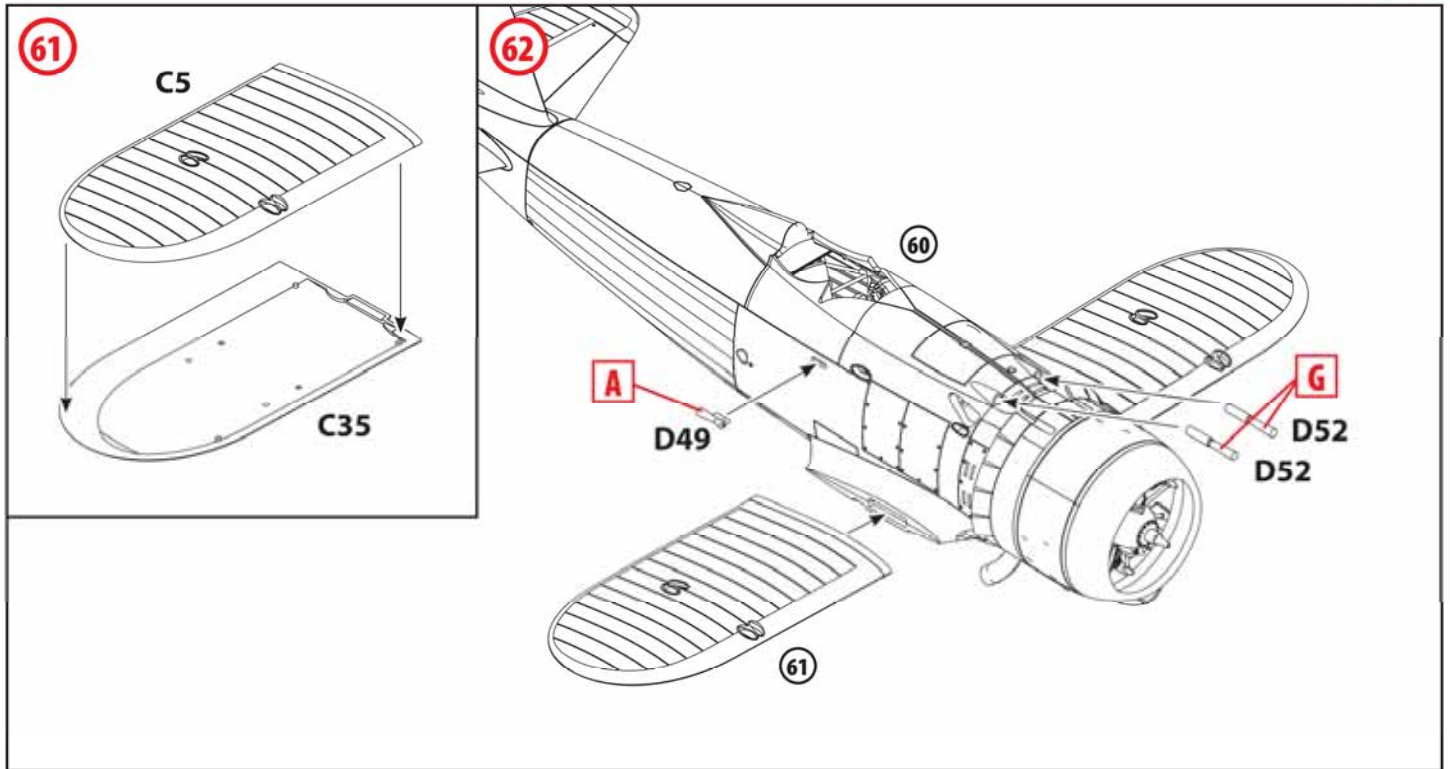

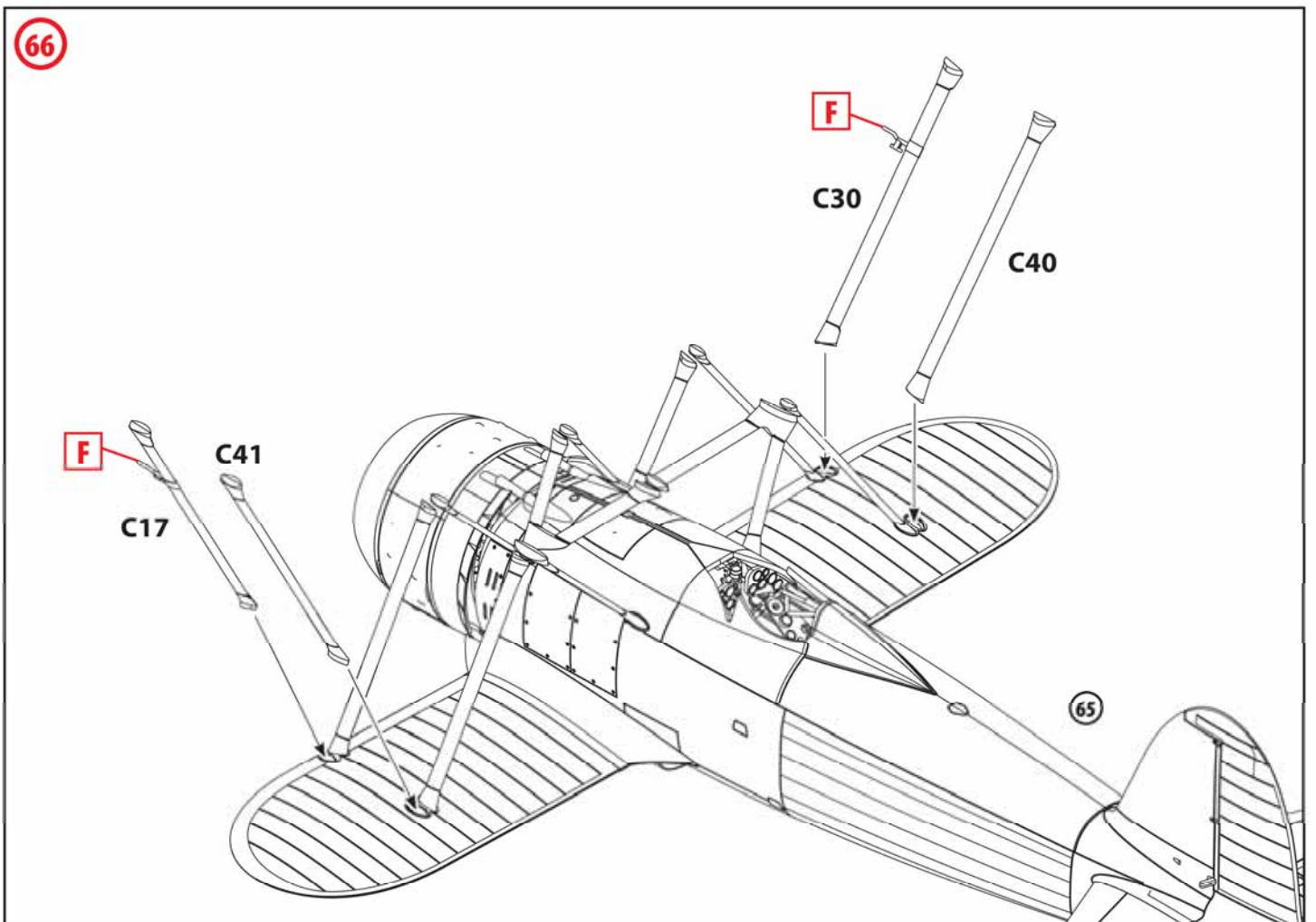
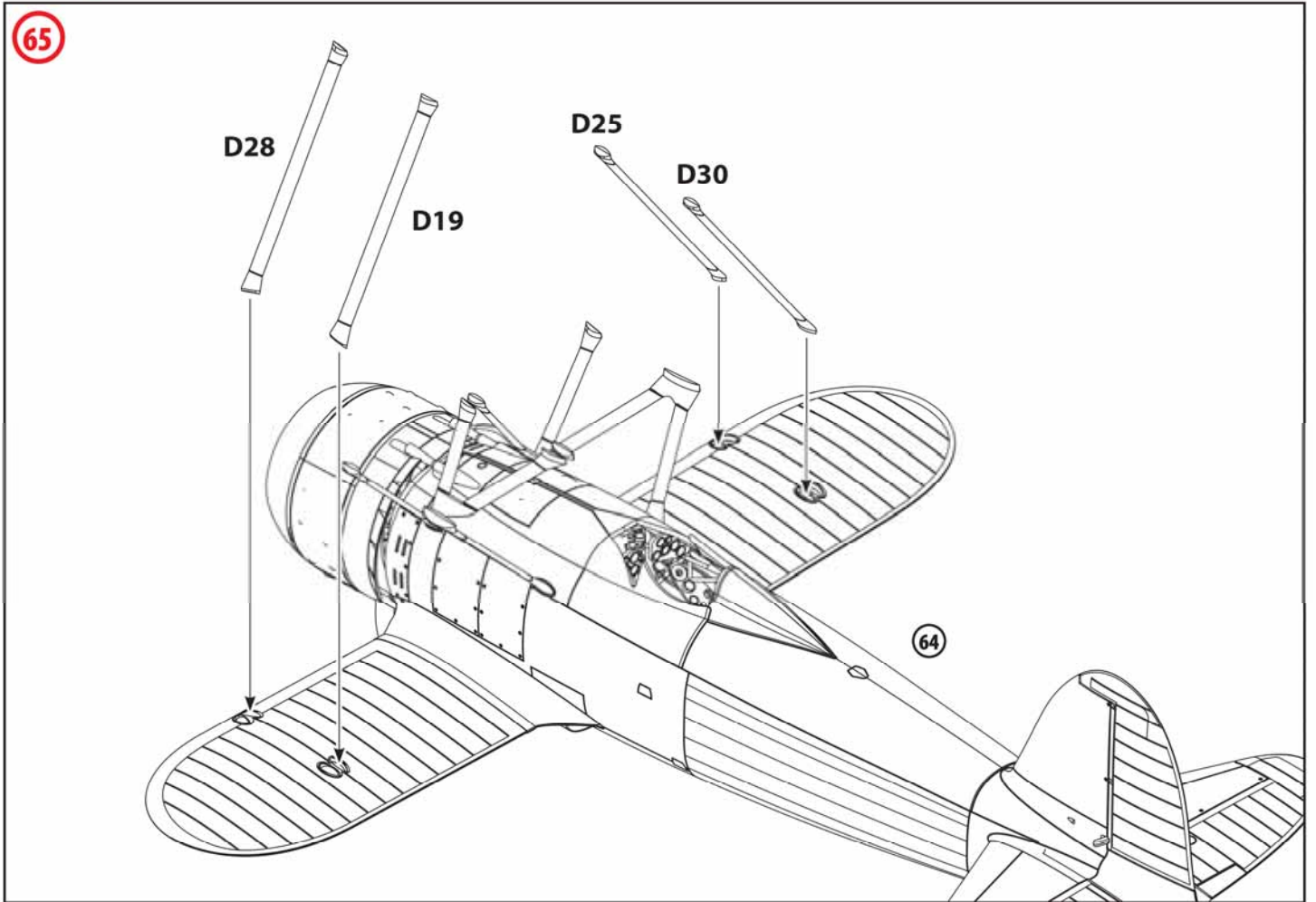

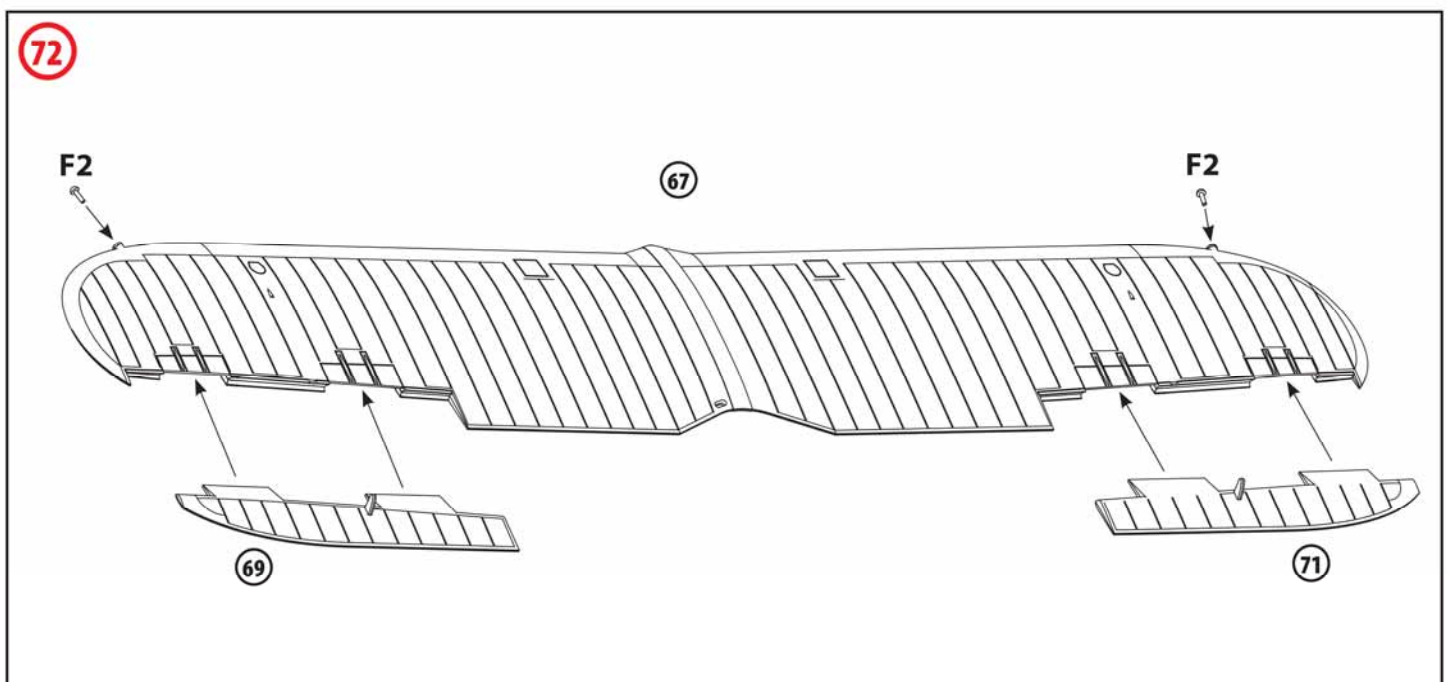
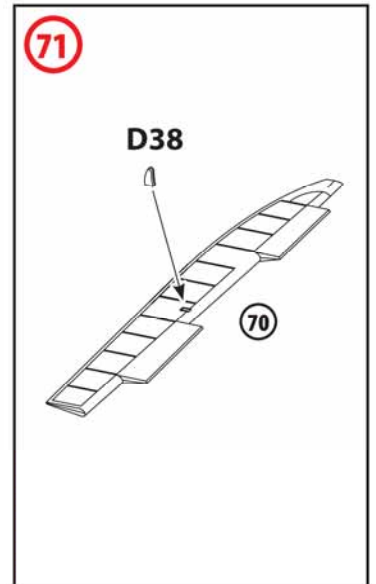
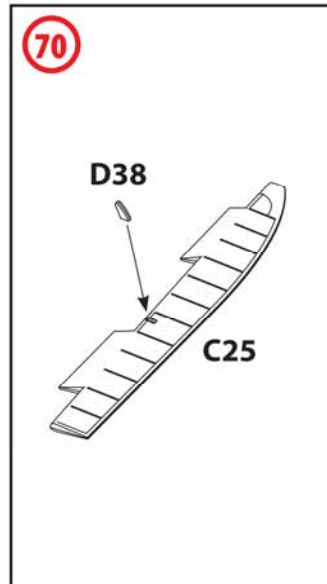
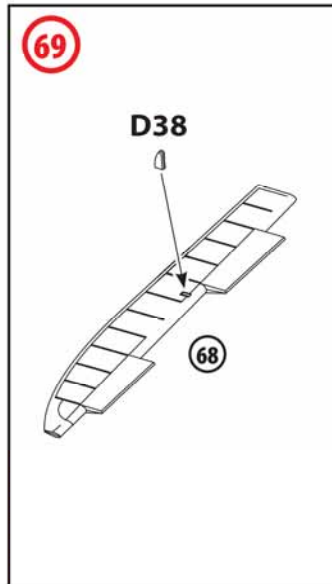
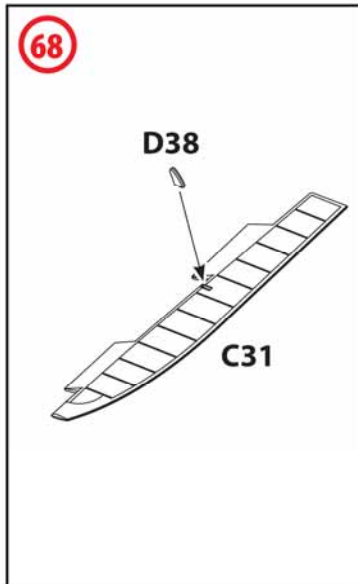
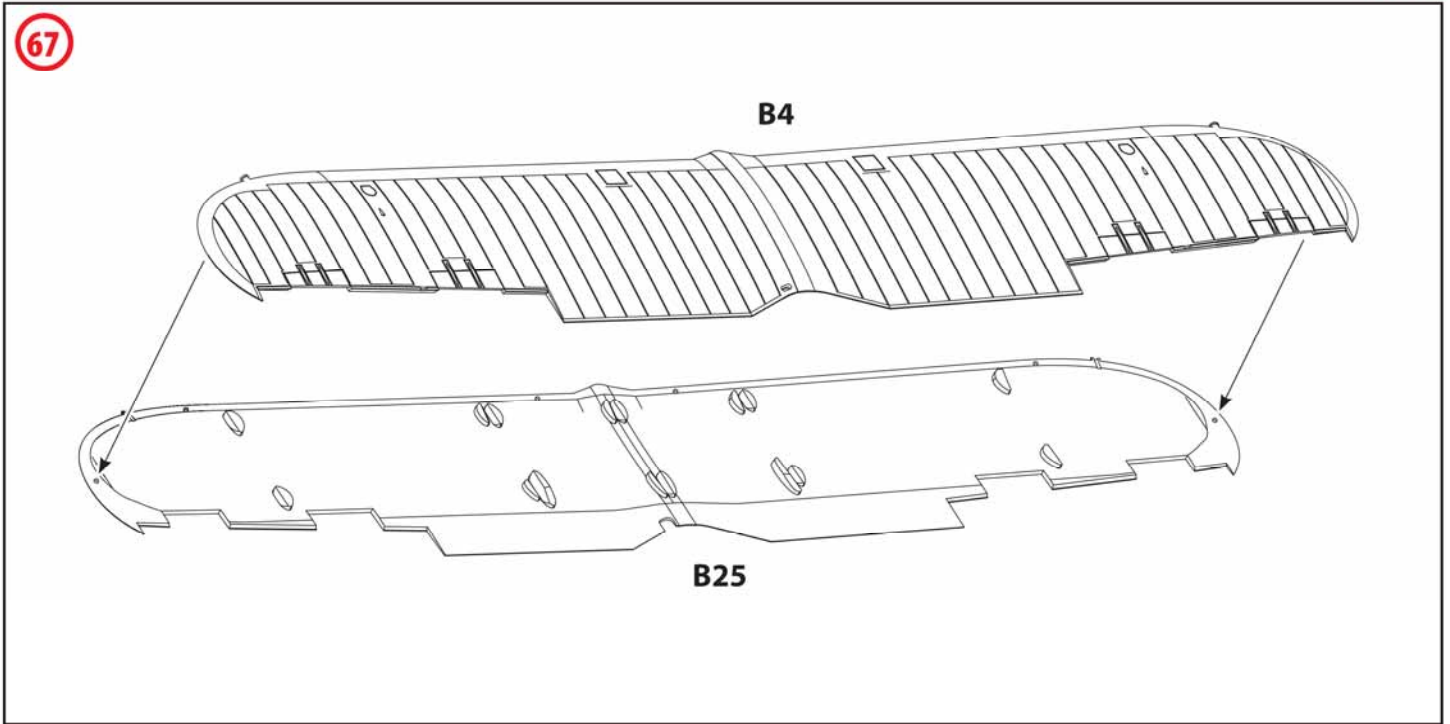

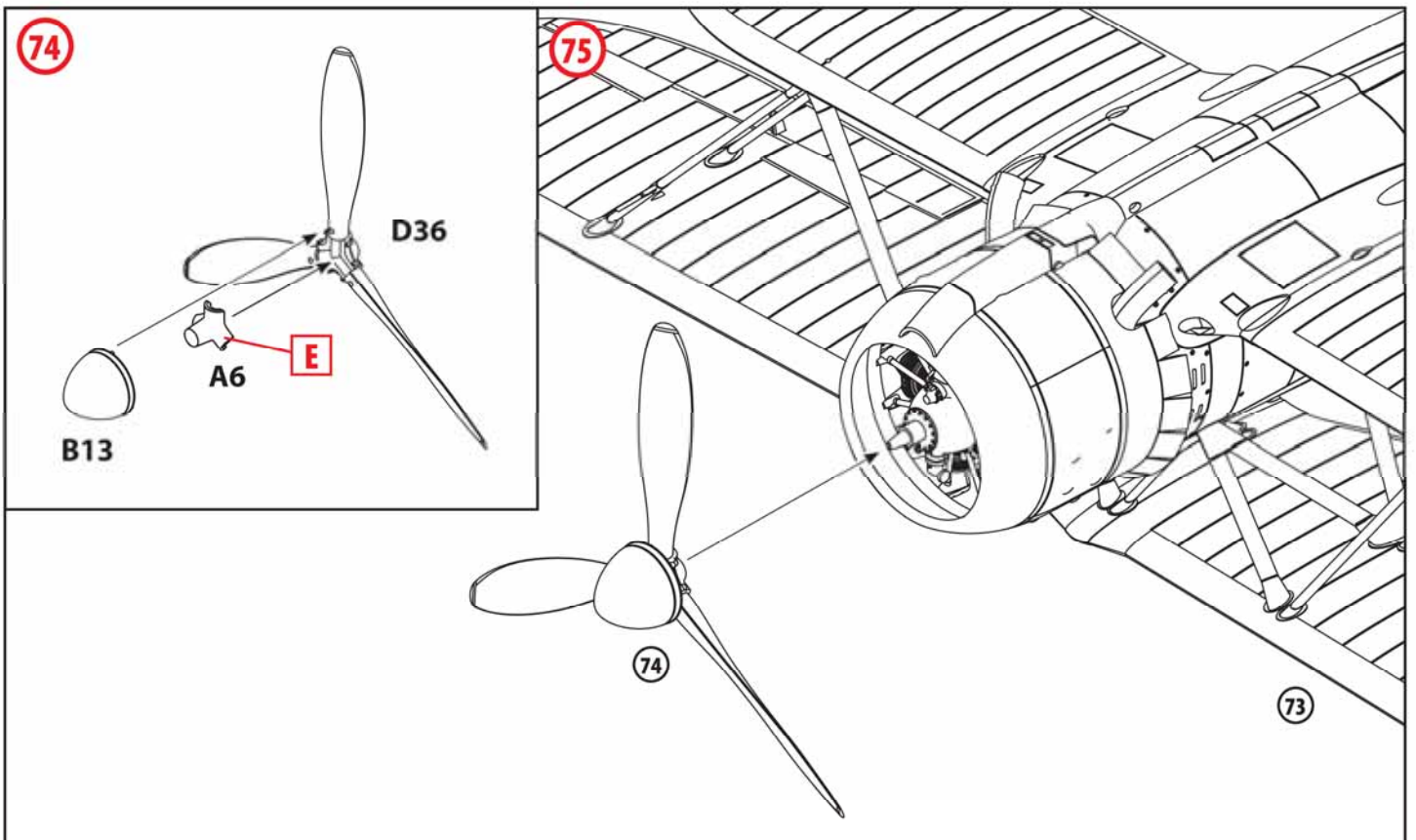
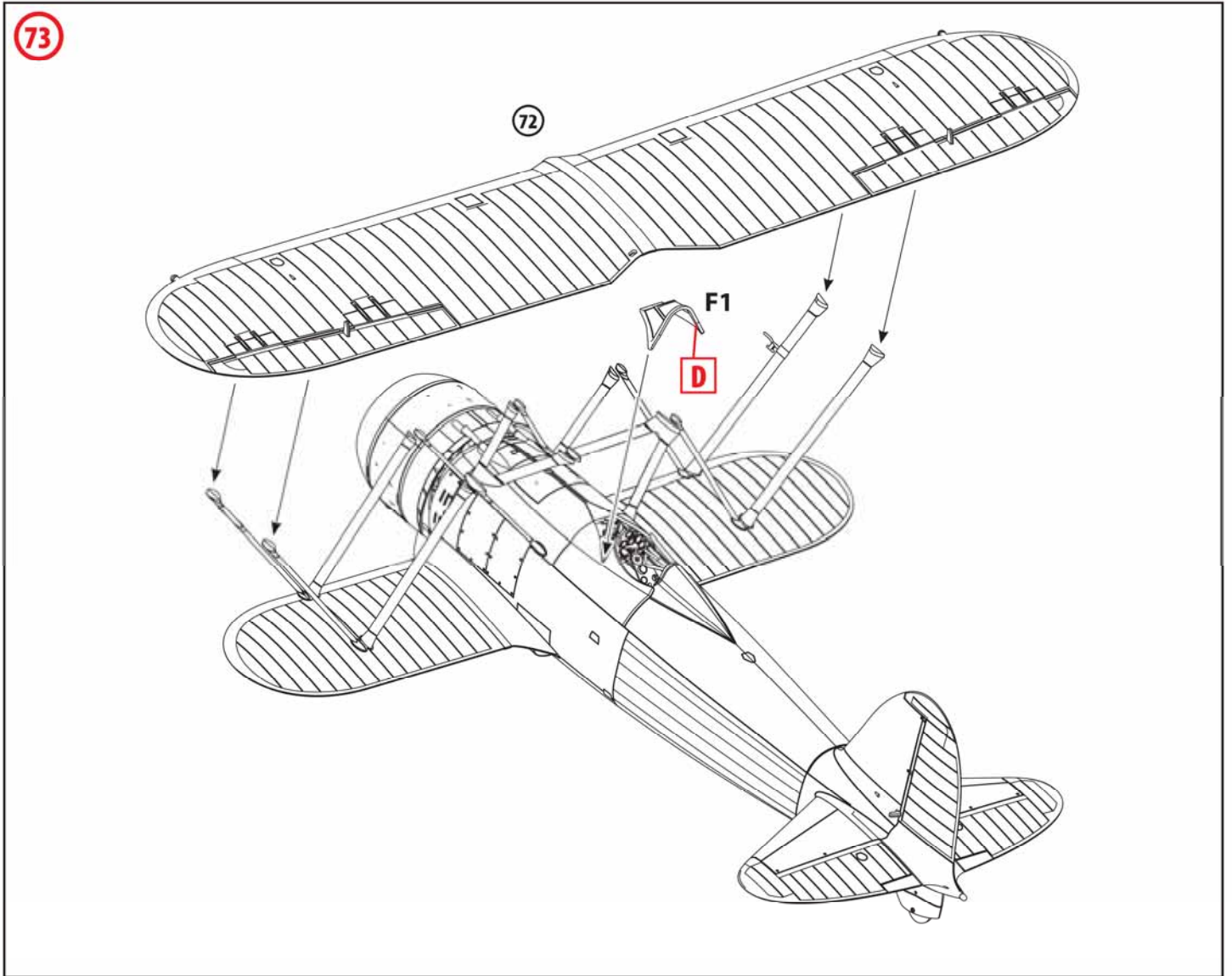



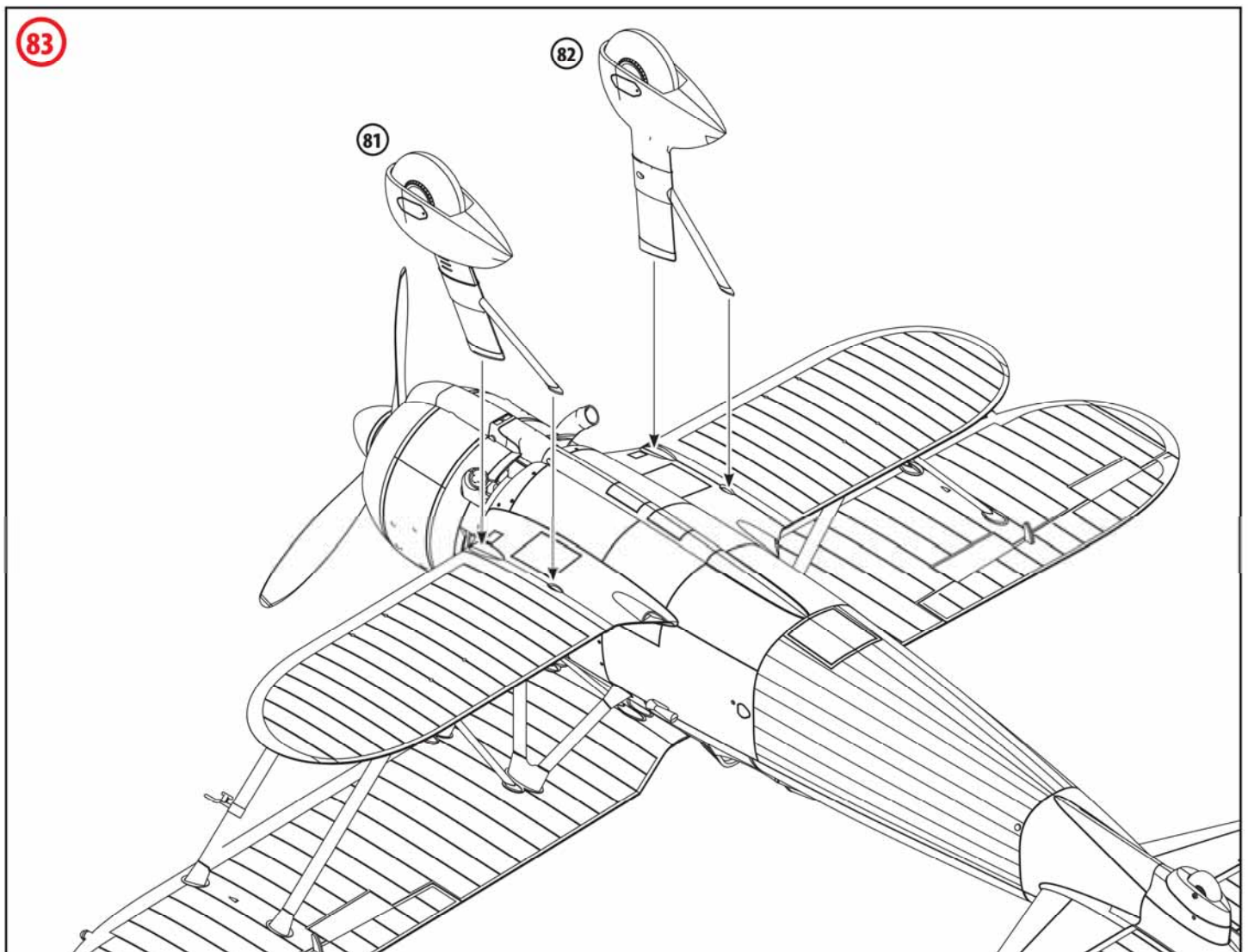
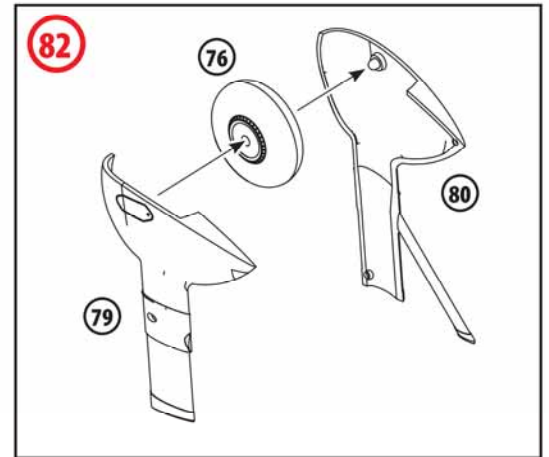
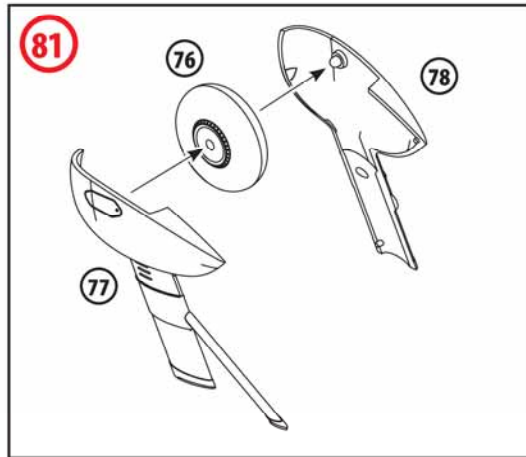
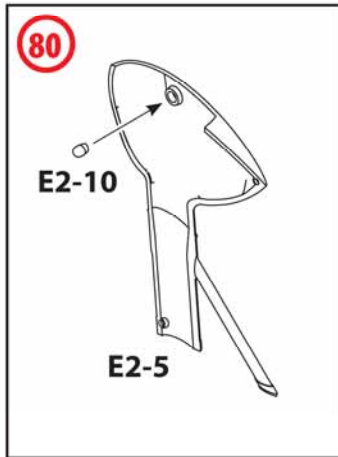
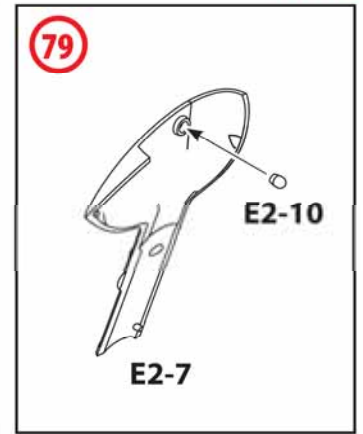
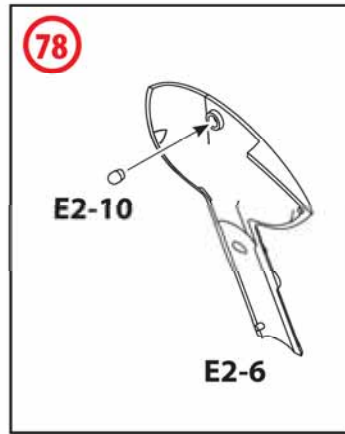
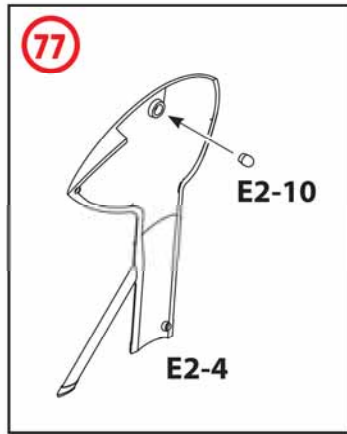
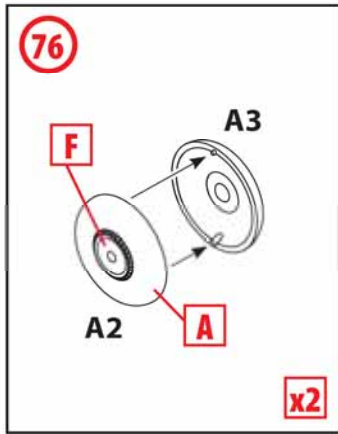

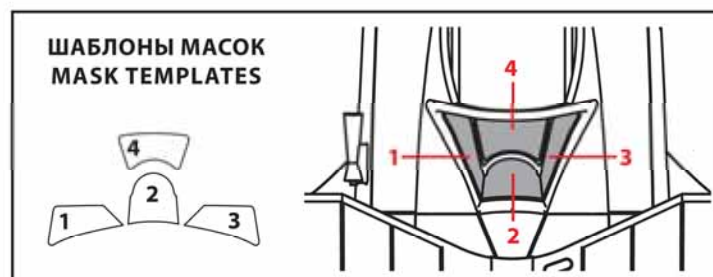
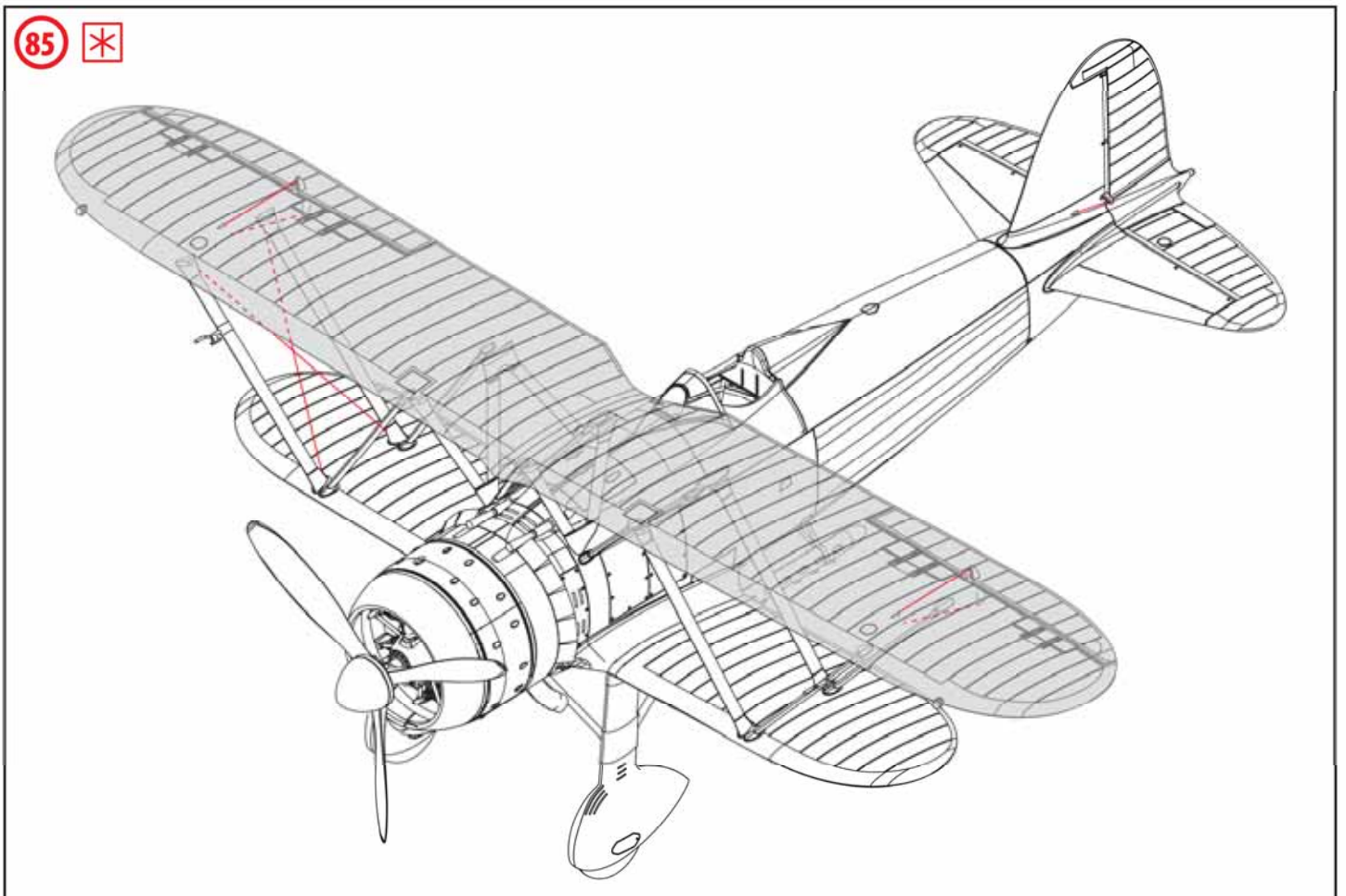
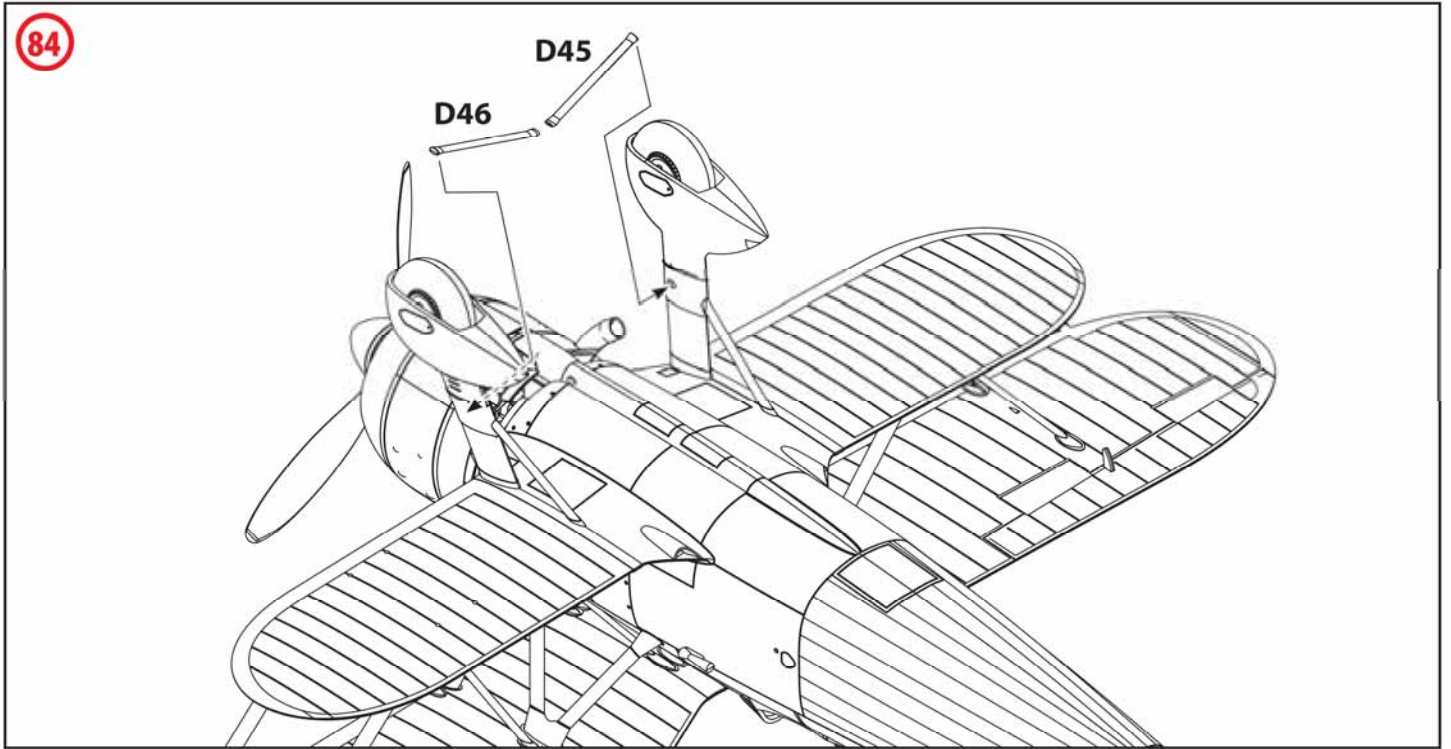

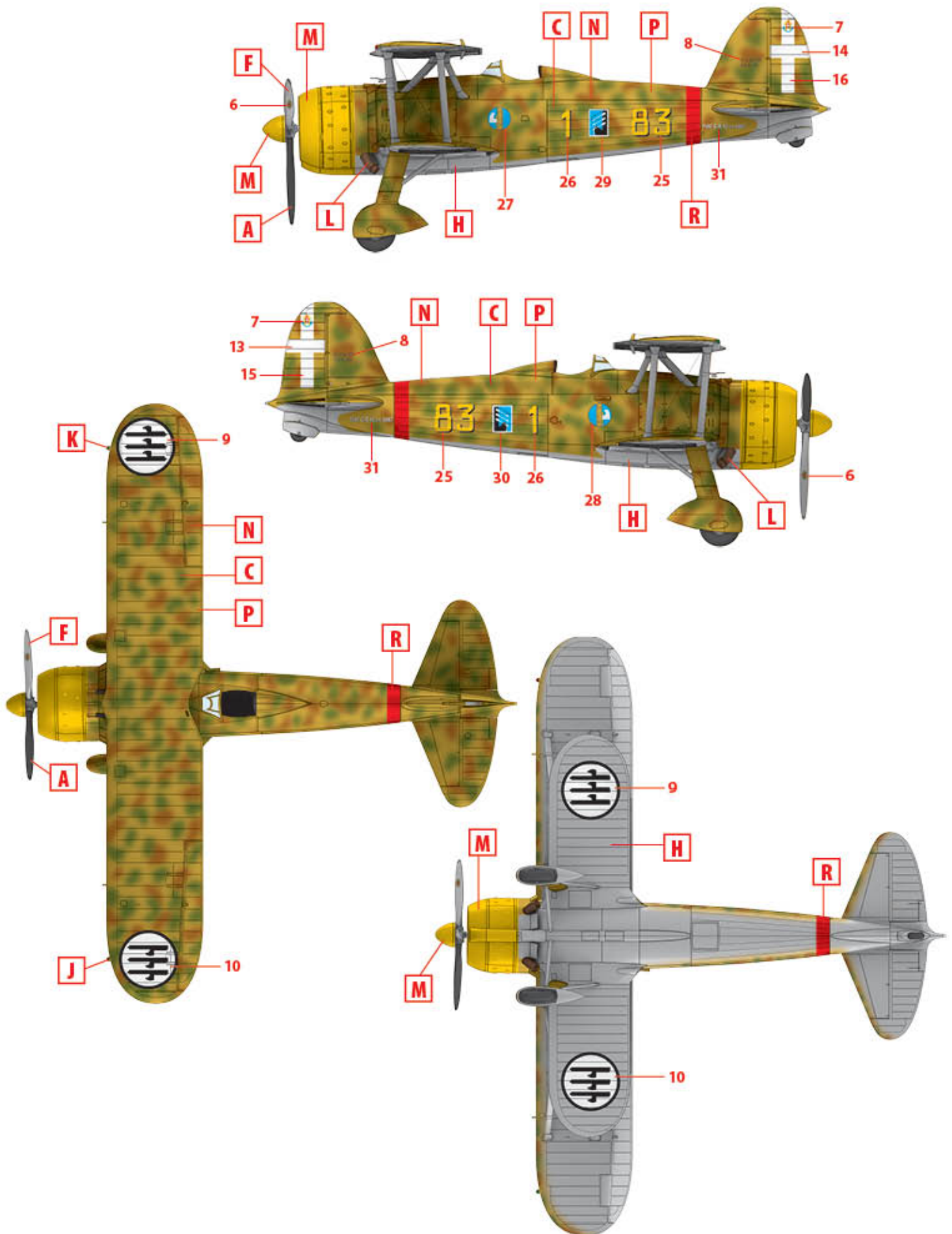

1. CR.42 Falco, 83-я эскадрилья, 18-я группа, 56-я эскадра, Урсель, Бельгия, ноябрь 1940 г.  
 CR.42 Falco, 83 Sq., 18 Gruppo, 56 Stormo C.T., Ursel, Belgium, November 1940

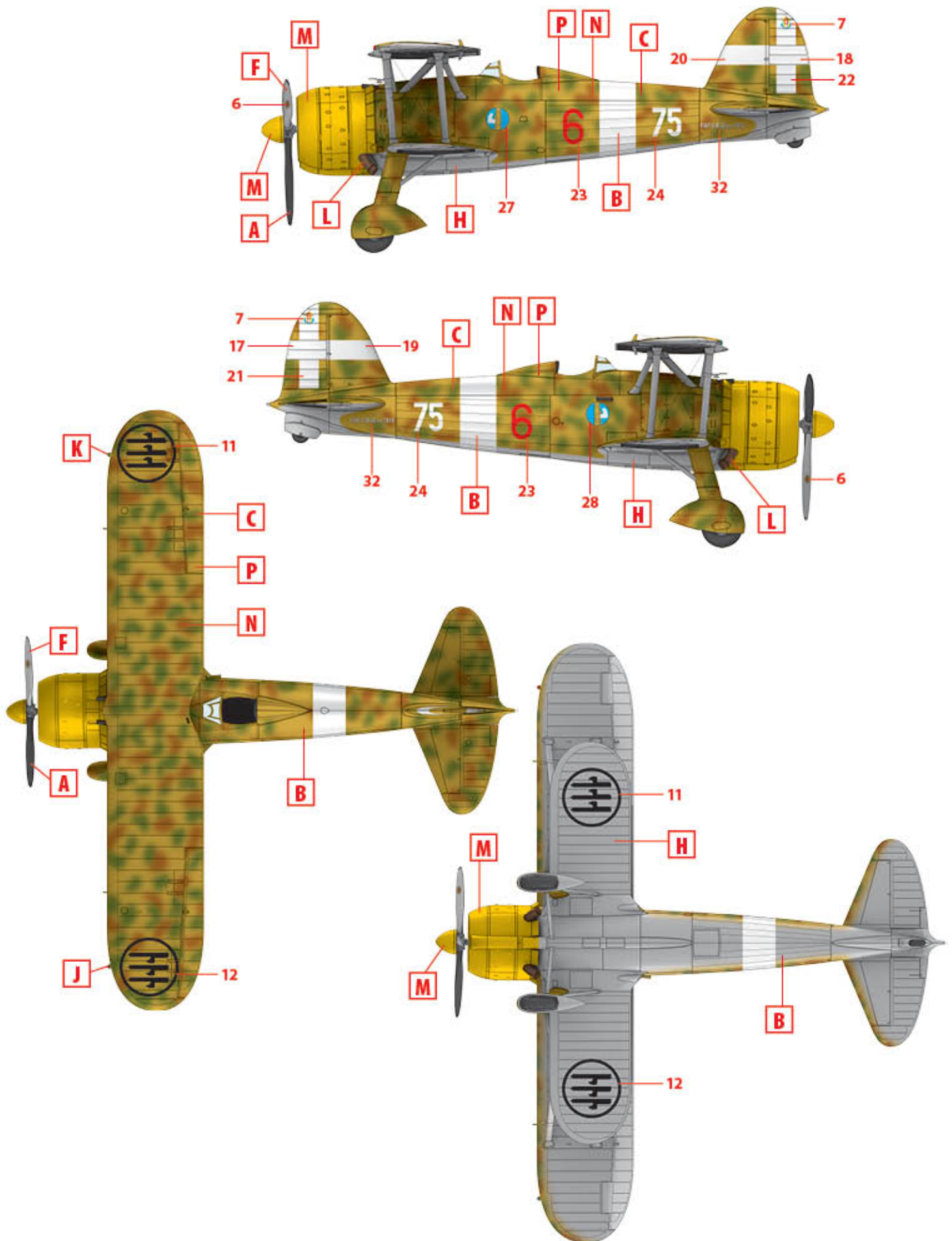

2. CR. 42 Falco, 75-я эскадрилья, 23-я отдельная группа, Сицилия, июнь 1941 г.  
 CR. 42 Falco, 75 Sq., 23 Gruppo Autonomo C.T., Sicily, June 1941