



# 'Desert Storm'

1/48 SCALE MODEL KIT No 48302

## «Буря в пустелі»

### Американські літаки OV-10A та OV-10D+, 1991 рік

2 серпня 1990 року Ірак розпочав вторгнення в Кувейт. У відповідь збройними силами багатонаціональної коаліції була розроблена та проведена операція під назвою «Буря в пустелі». Початком операції, що розпочалася 17 січня 1991 року, стали масовані авіаційні та ракетні удари сил союзників. У наземній фазі операції приймав участь Корпус морської піхоти США, авіація якого мала на озброєнні літаки OV-10 Bronco різних модифікацій. Ці літаки базувалися в Саудівській Аравії, та входили в склад 3-го авіакрила морської піхоти, виконували функції наведення, цілевказання та підтримки зв'язку. OV-10 Bronco знаходили вогневі позиції сил Іраку, по яким згодом відпрацьовували американські штурмовики та морська артилерія. Також вони підтримували атаки морської піхоти. Ця операція стала останнім епізодом бойового застосування літаків OV-10 Bronco у складі авіації Корпусу морської піхоти США, і в 1994 році вони були остаточно виведені з її бойового складу. Проте експлуатація різних модифікацій цих літаків продовжувалася в інших країнах світу.

## 'Desert Storm'

### US aircraft OV-10A and OV-10D+, 1991

On August 2, 1990, Iraq launched an invasion of Kuwait. In response, the multinational coalition's forces developed and conducted an operation called 'Desert Storm'. The start of the operation, which began on January 17, 1991, was a massive air and missile strike by Allied forces. The ground phase of the operation involved the US Marine Corps, whose aircraft was armed with OV-10 Bronco aircraft of various modifications. These aircraft were based in Saudi Arabia, and were part of the 3rd Marine Wing, providing guidance, targeting and communication. The OV-10 Bronco found firing positions of Iraqi forces, which were later used by American attack aircraft and naval artillery. They also supported Marine attacks. This operation was the last episode of combat use of OV-10 Bronco aircraft in the US Marine Corps, and in 1994 they were finally withdrawn from its combat. However, the operation of various modifications of these aircraft continued in other countries.

## ФАРБИ, ЩО ВИКОРИСТОВУЮТЬСЯ / USED COLORS:

COLOR	ICM 1000-6-10	Revell	Tamiya
<b>A</b> Чорний   Black	1002	-	XF1
<b>B</b> Камуфляжний зелений   Camouflage Green	1071	46	XF81
<b>C</b> Небесно-сіра   Sky Gray	1033	-	-
<b>D</b> Сіро-голубий   Grey Blue	1075 50% +1001 50%	-	-
<b>E</b> Дерев'яна палуба   Deck Tan	1055	-	XF57
<b>F</b> Світла земля   Light Earth	1056	16	XF59
<b>G</b> Мідь   Copper	1021	93	XF6
<b>H</b> Білий   White	1001	5	XF2
<b>J</b> Алюміній   Aluminium	1023	99	XF16
<b>K</b> Збройовий метал   Gun metal	1027	-	X10

COLOR	ICM 1000-6-10	Revell	Tamiya
<b>L</b> Синьо-сіра   Blue Grey	1032	55	XF80
<b>M</b> Масляна сталь   Oily Steel	1026	-	-
<b>N</b> US Темно-зелений   US Dark Green	1072	363	XF13
<b>P</b> Жовтий   Deep Yellow	1003	-	XF3
<b>Q</b> Латунь   Brass	1018	92	-
<b>R</b> Чорна гума   Rubber Black	1039	-	XF85
<b>S</b> Коричнева шкіра   Leather Brown	1053	-	XF10
<b>T</b> Напівпрозорий зелений   Clear Green	1014	-	X25
<b>U</b> Напівпрозорий червоний   Clear Red	1011	731	X27
<b>V</b> Напівпрозорий синій   Clear Blue	1012	752	X23

Для отримання глянцевого, сатинового чи матового ефекту – використовуйте наші лаки!

For a glossy, satin or matte effect – use our varnishes!



2001  
МАТОВИЙ ЛАК  
VARNISH MATT



2002  
САТИНОВИЙ ЛАК  
VARNISH SATIN



2003  
ГЛЯНЦЕВИЙ ЛАК  
VARNISH GLOSS

- 01** СТАДІЯ СКЛАДАННЯ  
ASSEMBLY STEP
- A** ФАРБА, ЩО ВИКОРИСТОВУЄТЬСЯ  
USED COLOR
- ПРИ СКЛАДАННІ НЕ ВИКОРИСТОВУЄТЬСЯ  
PARTS NOT FOR USE
- ПРОСВЕРДЛИТИ  
OPEN HOLE
- 03** СКЛАДАЛЬНА ОДИНИЦЯ  
ASSEMBLY UNIT
- ?** ДОВІЛЬНИЙ ВИБІР  
OPTIONAL
- x2** ЗРОБИТИ ДВІ ДЕТАЛІ  
MAKE 2 PCS
- ✂** ВІДРІЗАТИ  
CUT OFF
- ☰** КЛЕЇТИ  
GLUE
- ✖** НЕ КЛЕЇТИ  
DO NOT CEMENT

У В А Г А !  
Перед складанням уважно прочитати керівництво з монтажу. Кожна деталь пронумерована. Дотримуватися послідовності монтажу. Необхідні робочі інструменти: ніж і напилек для зачистки деталей; гумова стрічка, клейка стрічка і прищипки для білизи (для притиснення склеюваних деталей). Деталі з пластику очистити в розчині м'якого миючого засобу і висушити на повітрі для того, щоб фарба і первідні картинки краще прилипали. Перед приклеюванням перевірити, чи підходять деталі; клей наносити економно. Хром і фарбу видалити з поверхонь склеювання. Невеликі деталі пофарбувати перед тим, як вони будуть видалені з рамки. Фарбу необхідно добре просушити, тільки після цього продовжувати складання. Кожну відповідну первідну картинку вирізати акуратно і приблизно на 20 секунд занурити в теплу воду. На позначеному місці картинку відокремити від паперу і притиснути промокальним папером.

С А У Т І О Н !  
Read the instructions thoroughly prior to assembly. Each component is numbered. Adhere to specified sequence of assembly. Tools required: knife and file for removal of components from frame; rubber bond, adhesive tape and clothes pegs for clamping components together after applying adhesive. Clean plastic components in a mild detergent solution and allow to air-dry so that paint and transfers adhere better. Prior to applying adhesive, check to see whether the components fit together; apply adhesive sparingly. Remove chrome and paint from the contact surfaces. Paint small components before removing them from the frame. Allow paint to dry well, and only then continue to assemble. Cut out each transfer individually and immerse in warm water for approx. 20 seconds. Slide transfer off paper and into designated position, then press on with blotting paper.

**ТОВ ICM Холдинг**  
вул. Бориспільська 9, корпус 64,  
02099, Київ, Україна  
Тел./факс: +38(044) 369 54 12  
E-mail: export@icm.com.ua



**ICM Holding**  
Borispolskaya, 9, build. 64,  
02099, Kiev, Ukraine  
Tel./Fax: +38(044) 369 54 12  
E-mail: export@icm.com.ua

# OV-10A Bronco

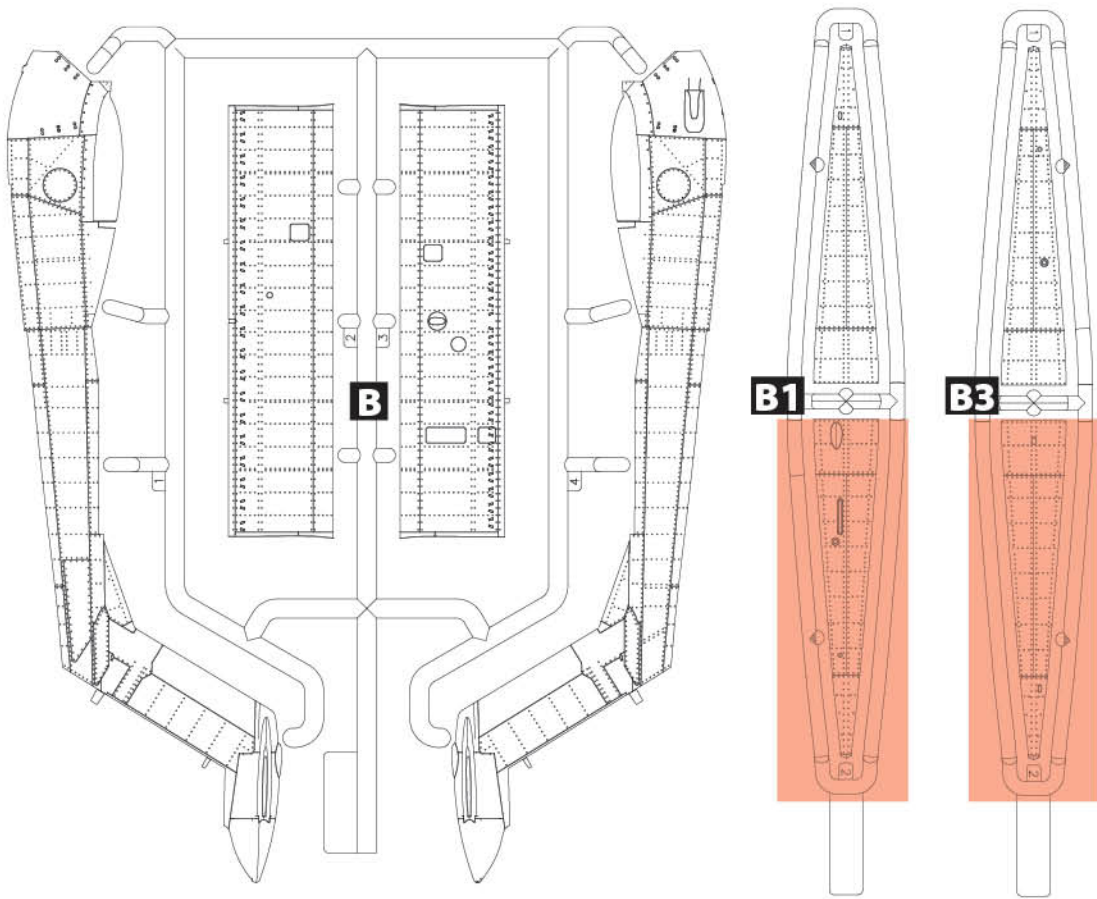
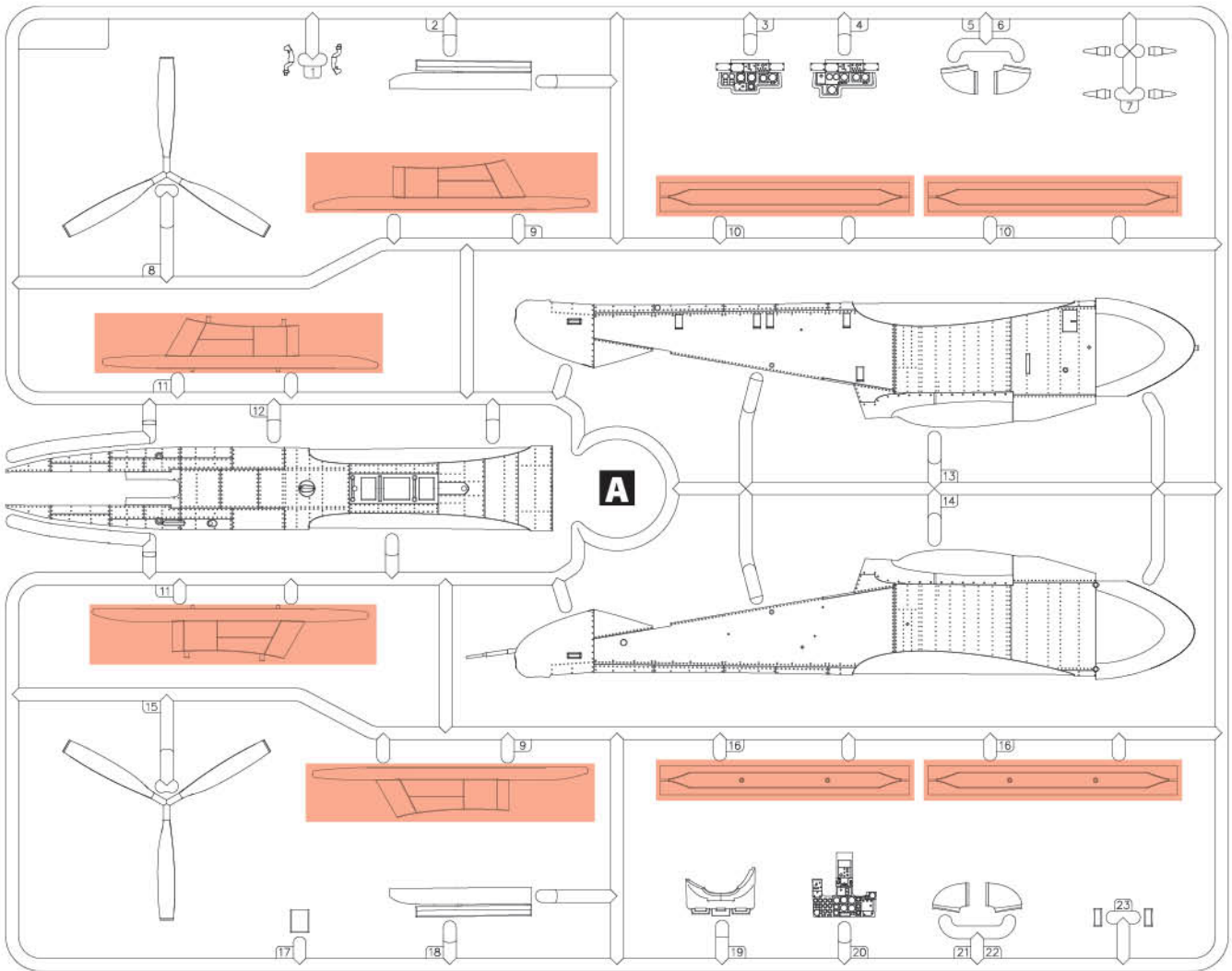

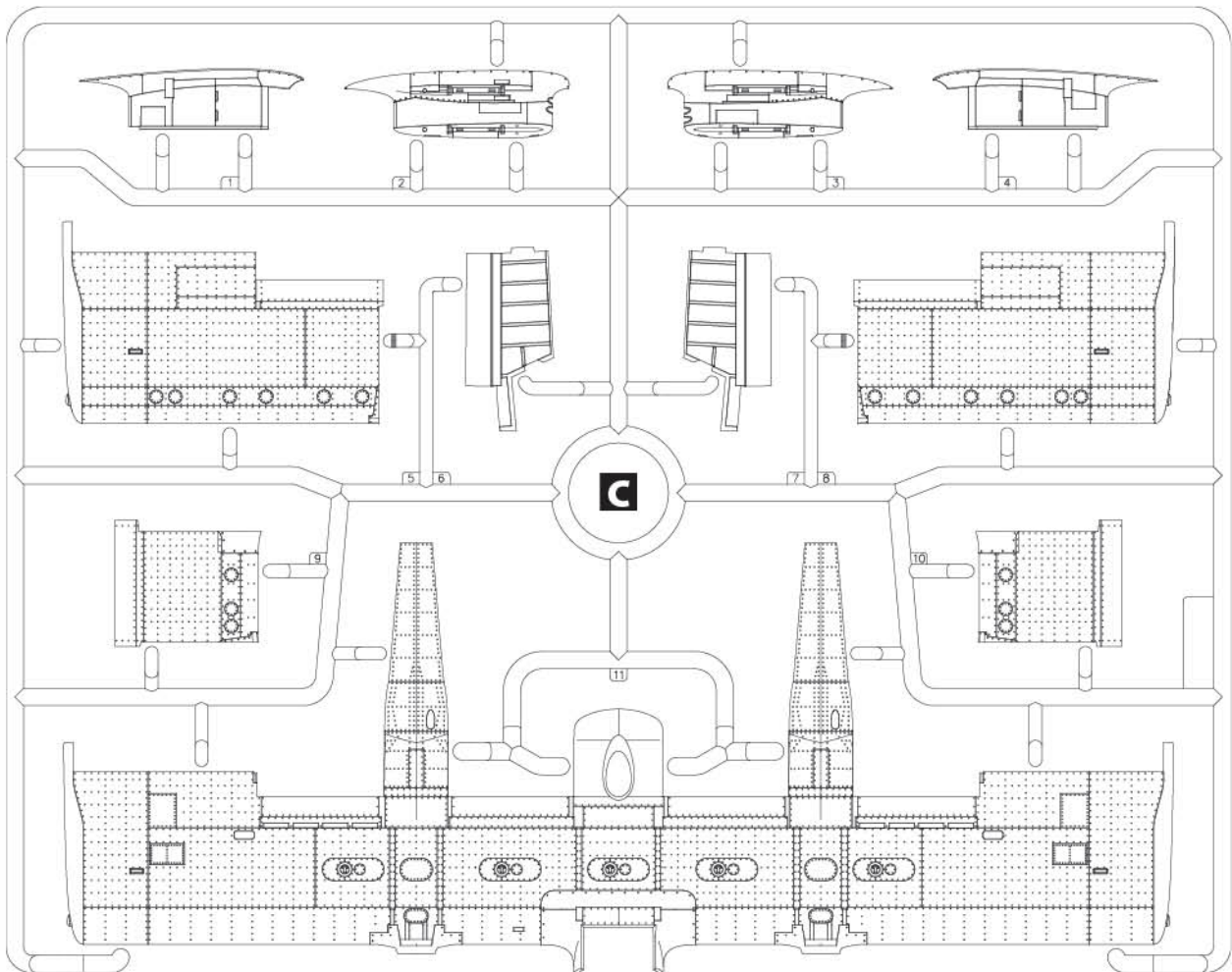
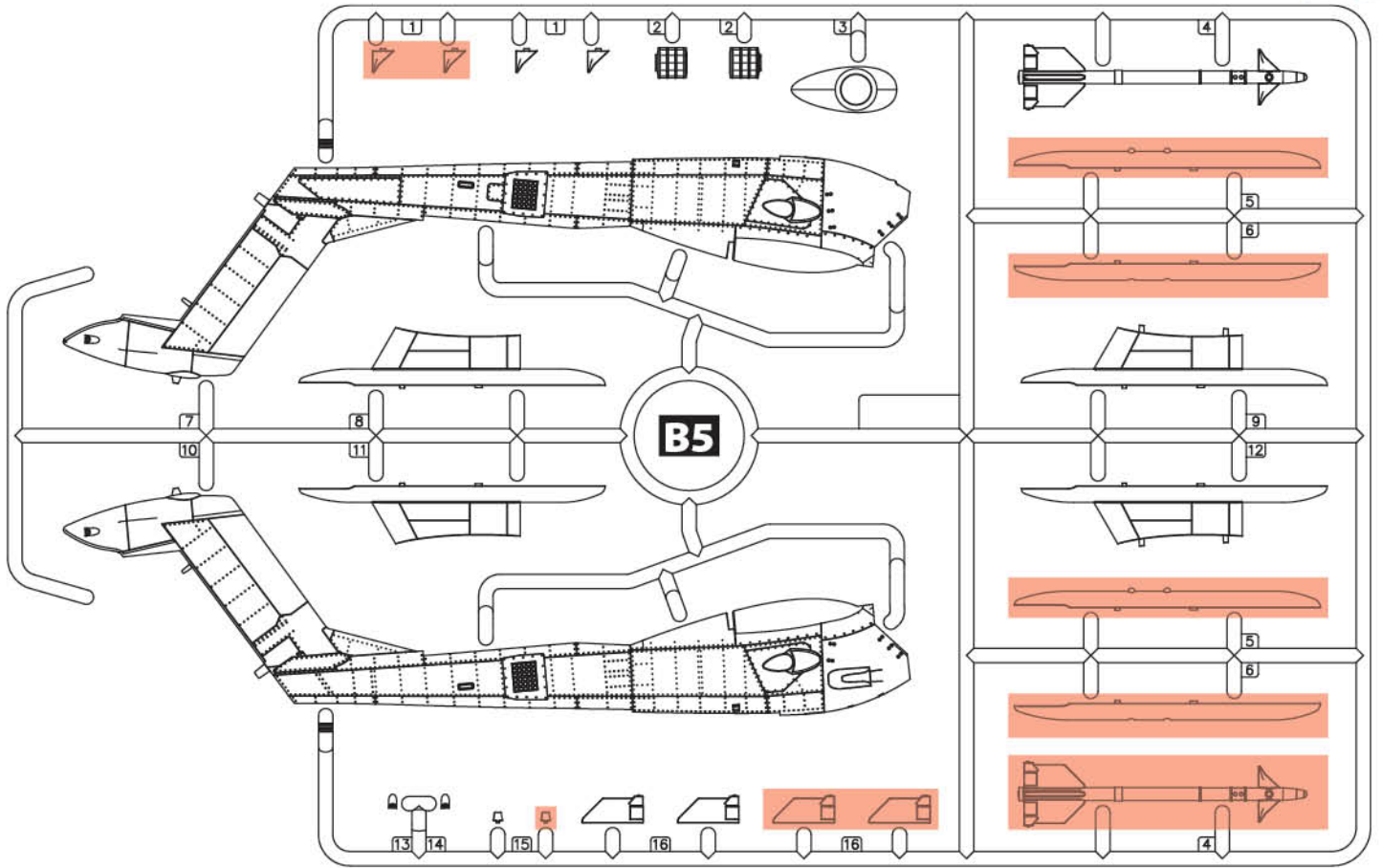

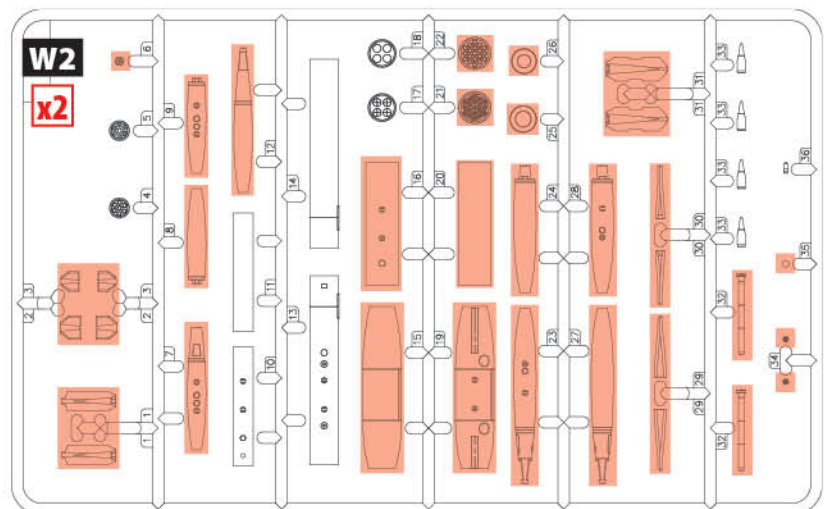
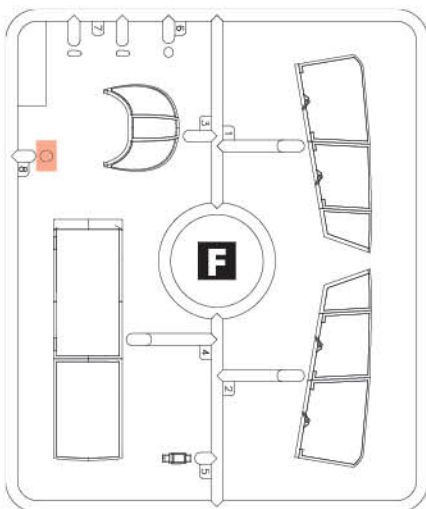
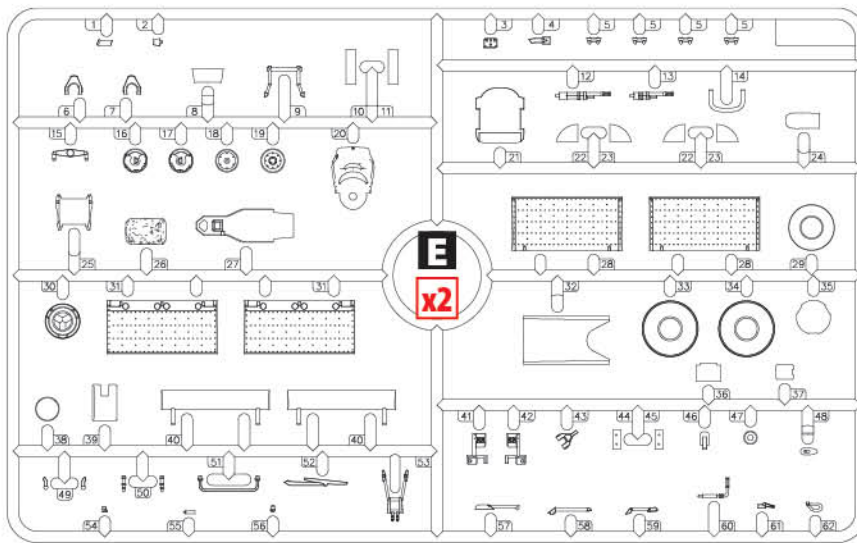
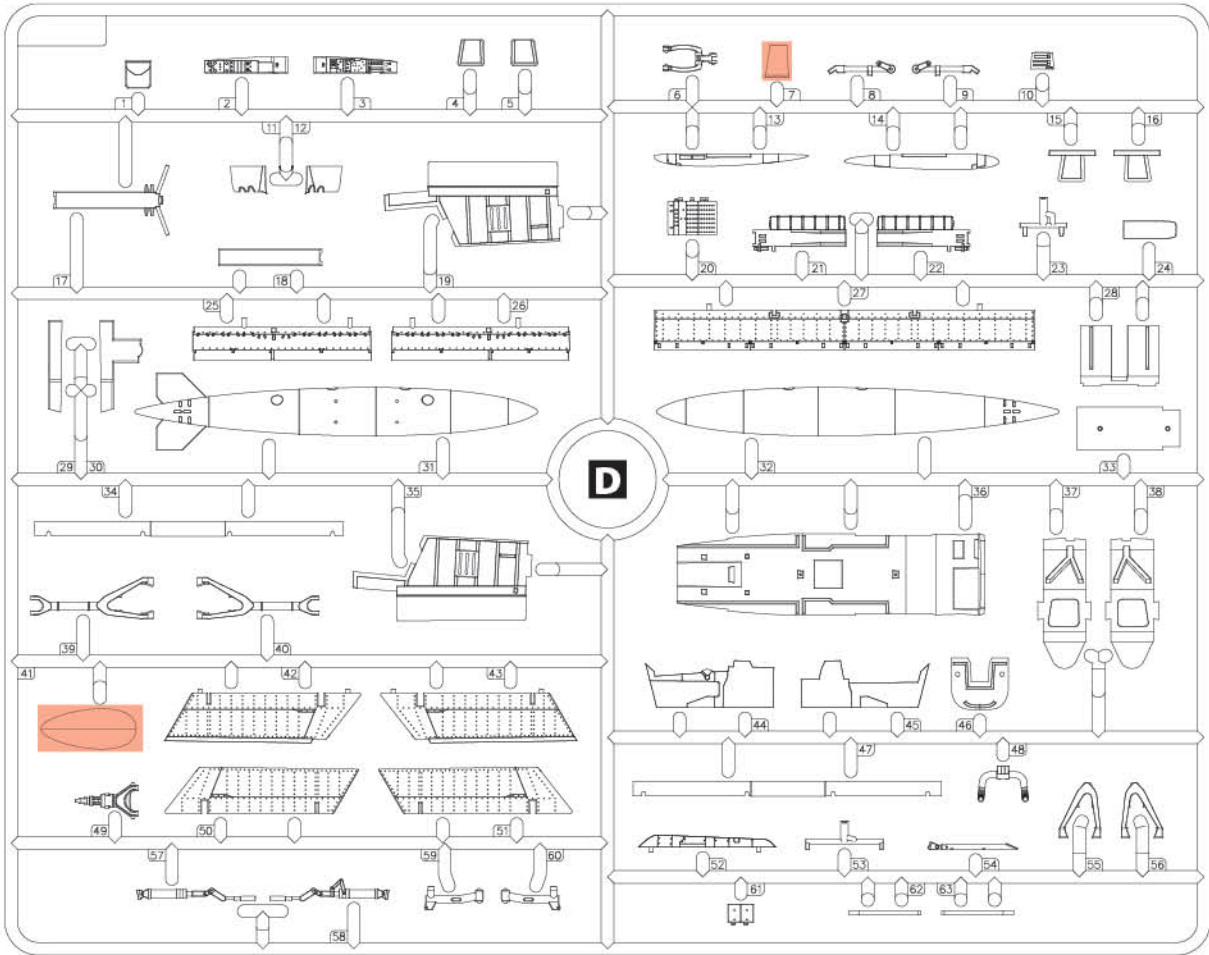

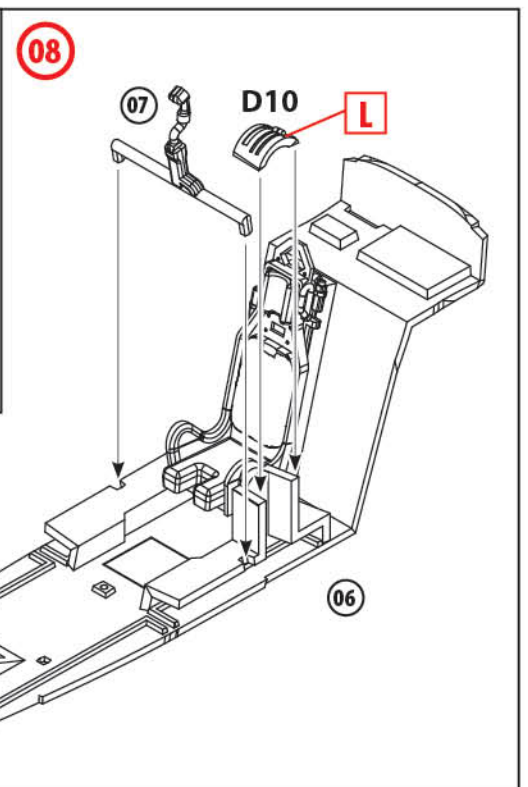
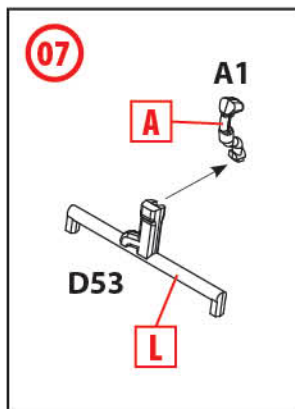
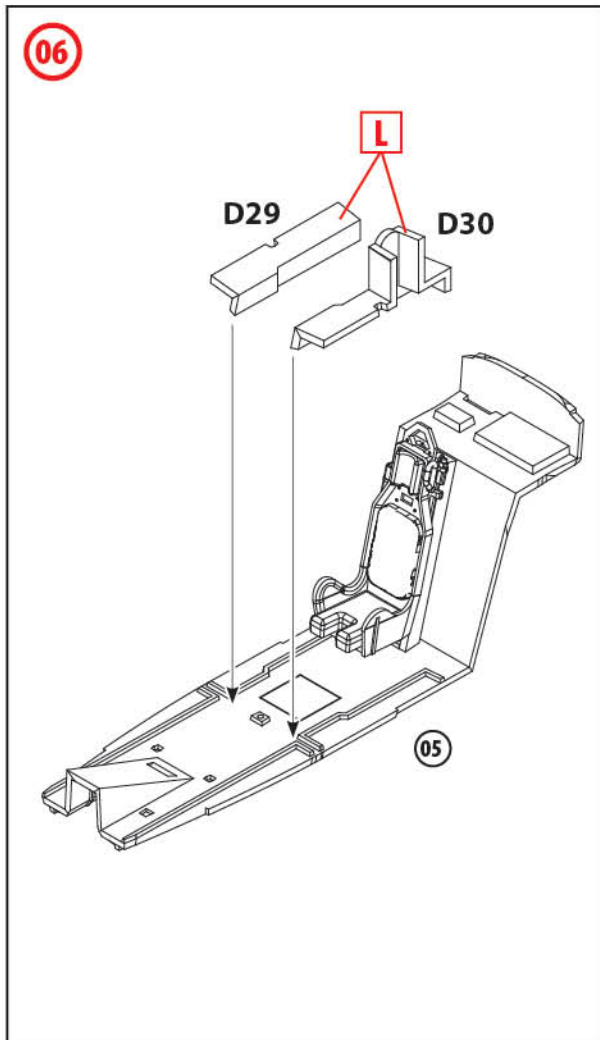
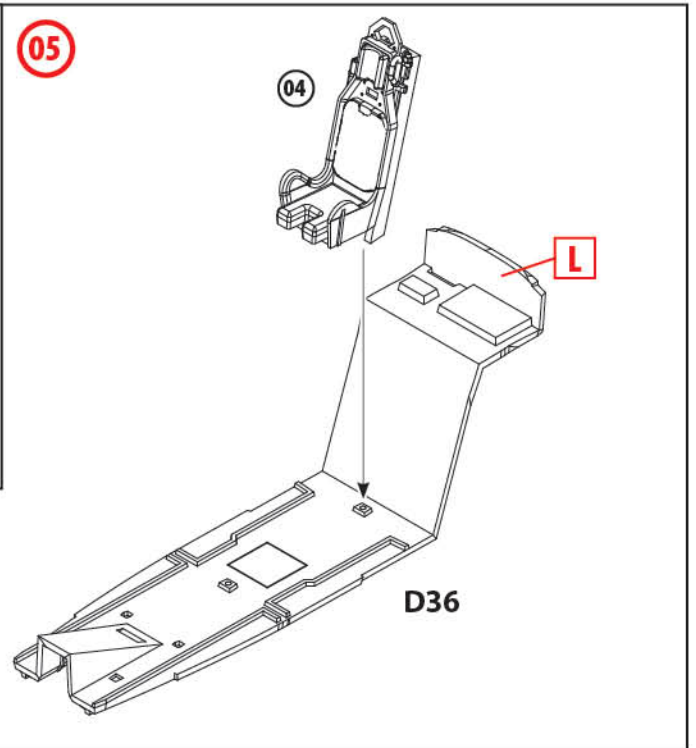
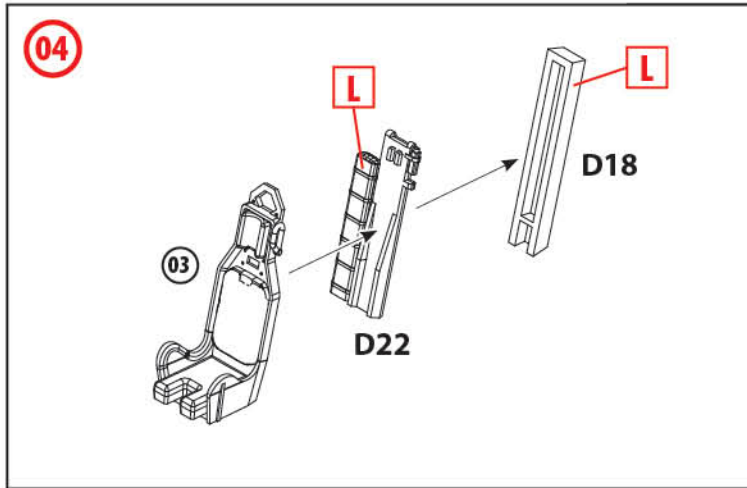
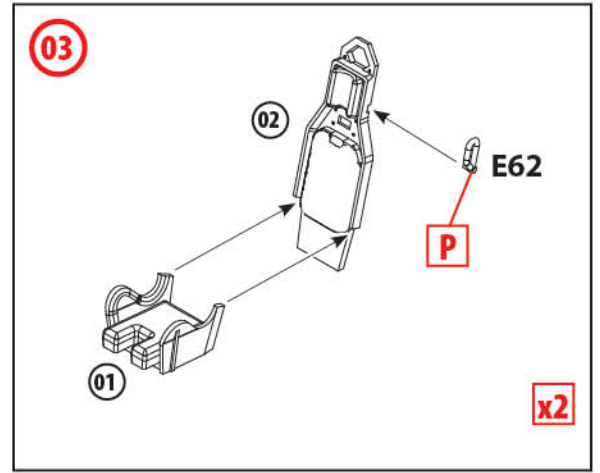
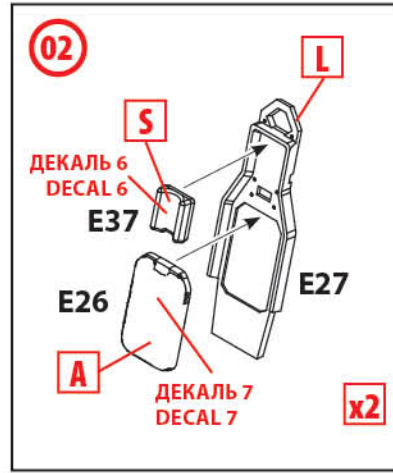
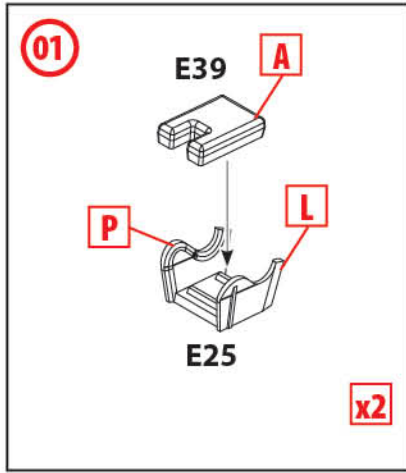

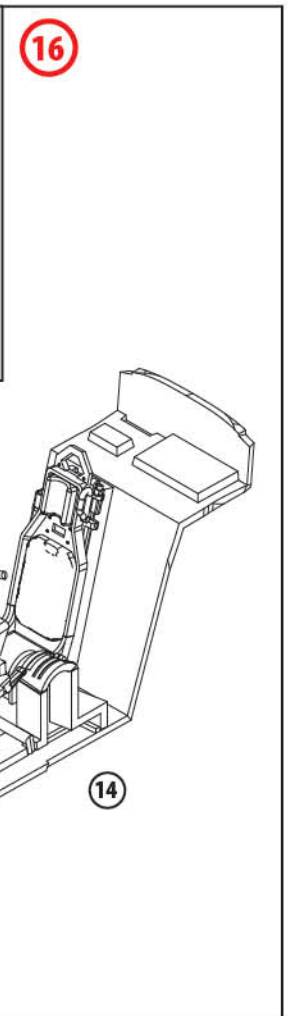
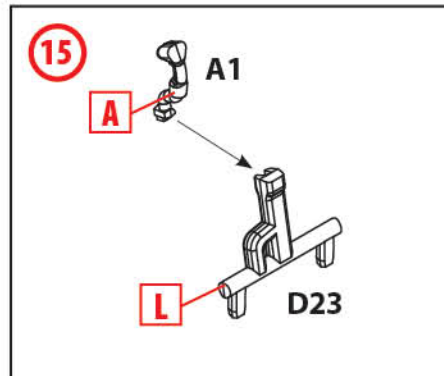
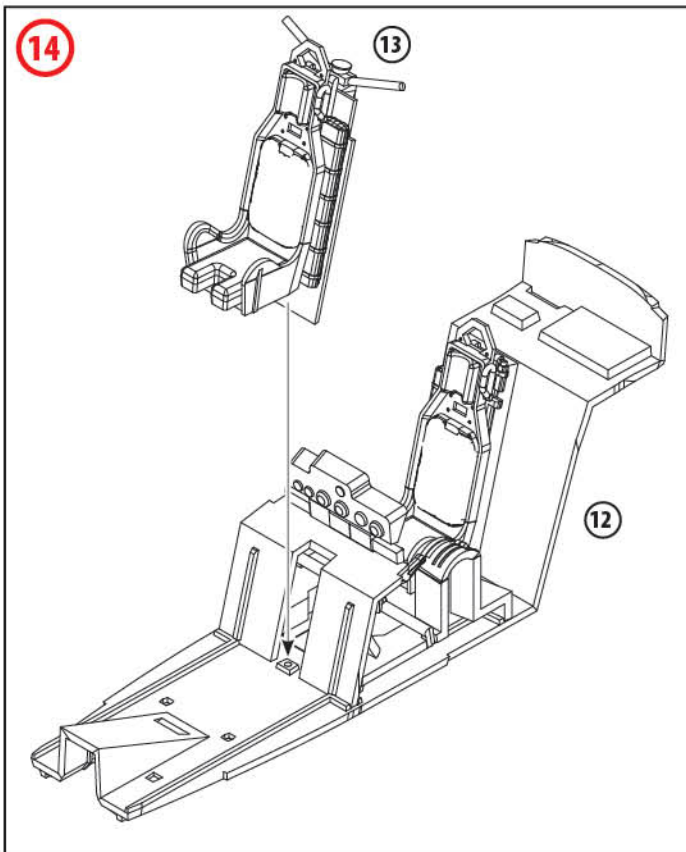
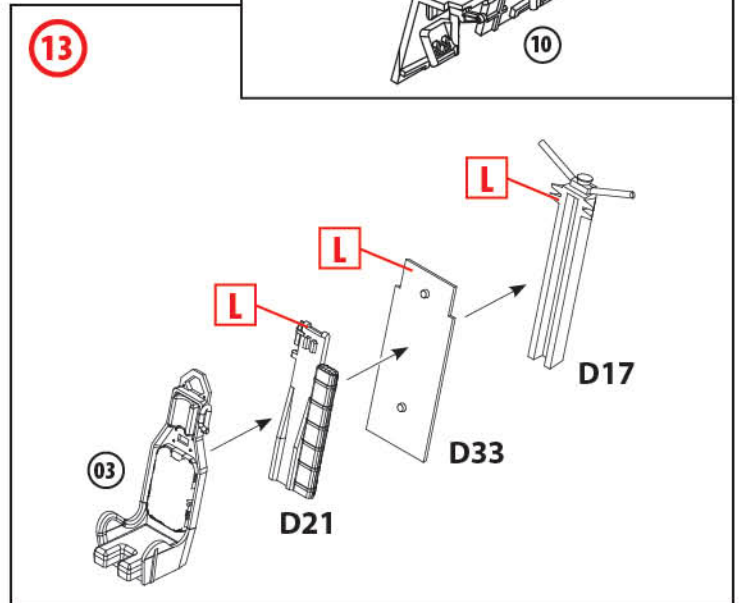
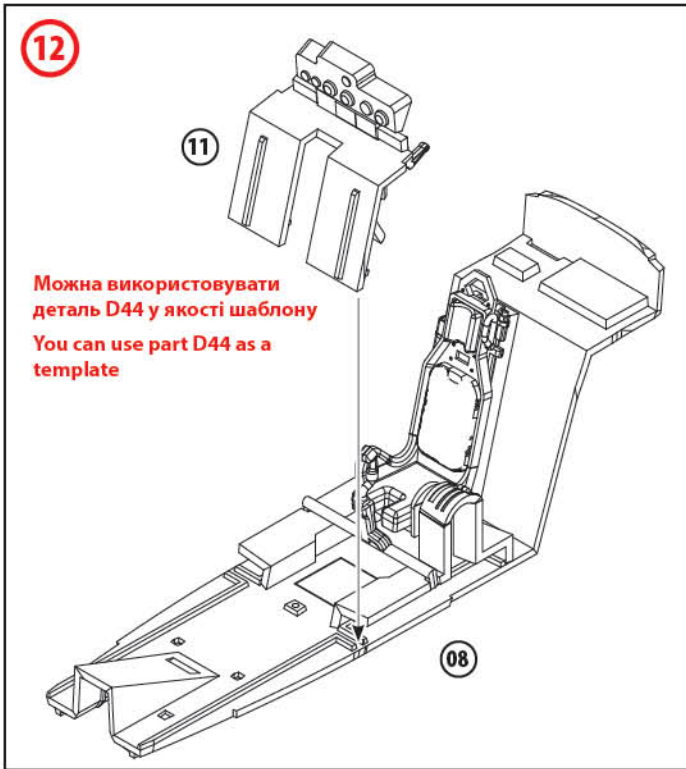
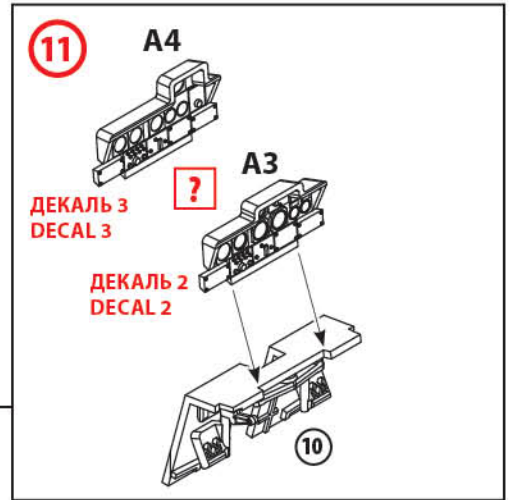
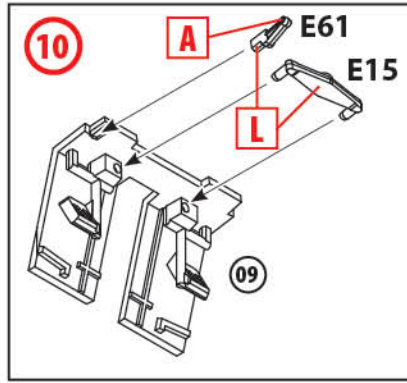
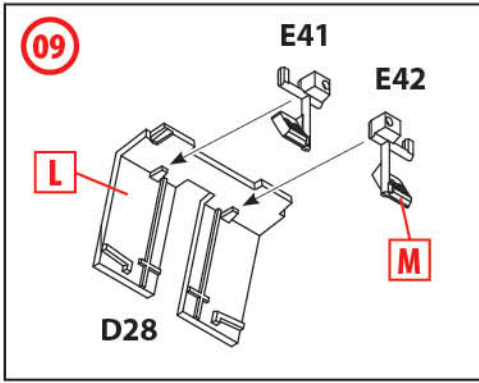

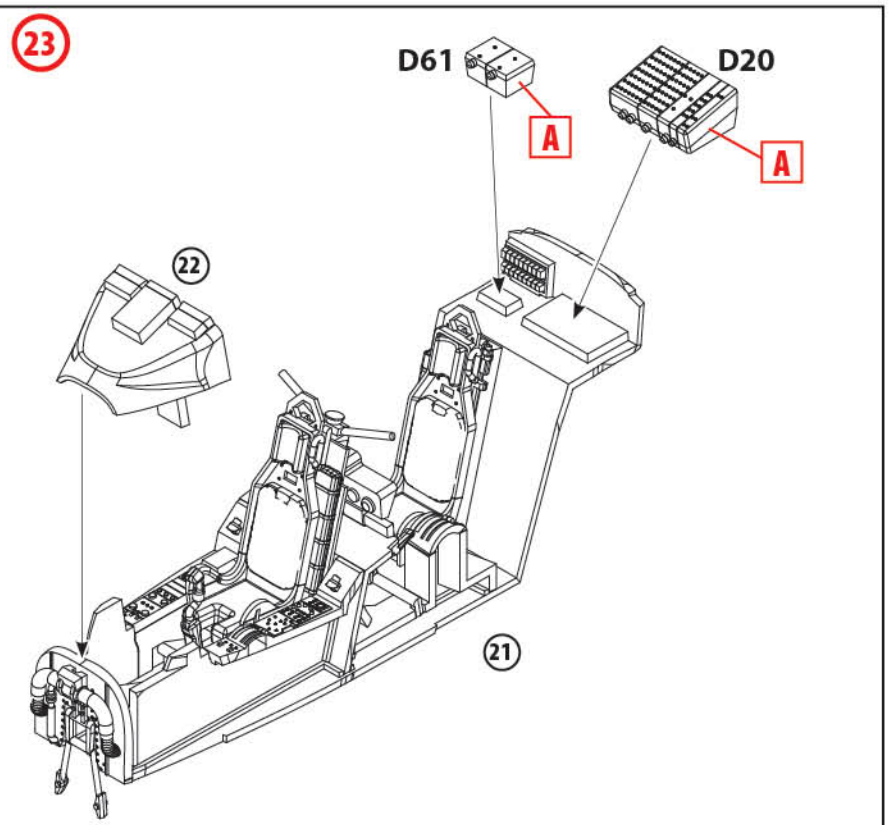
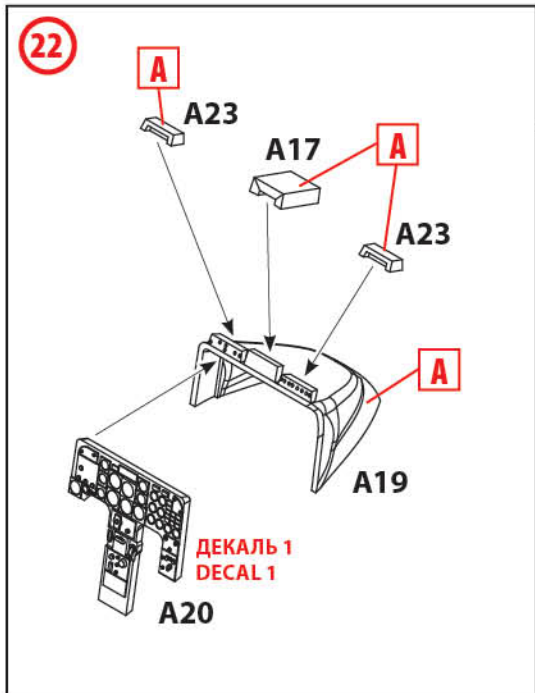
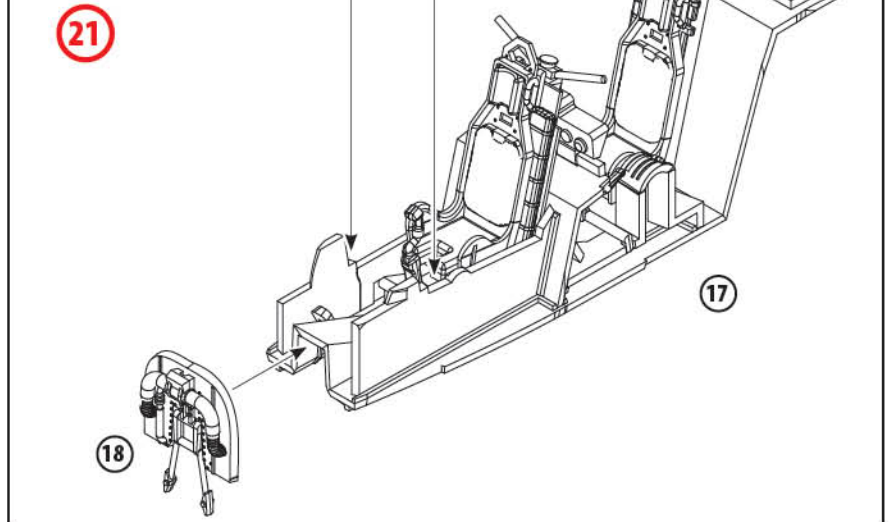
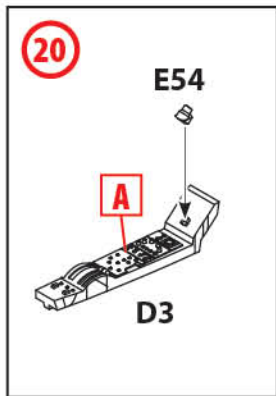
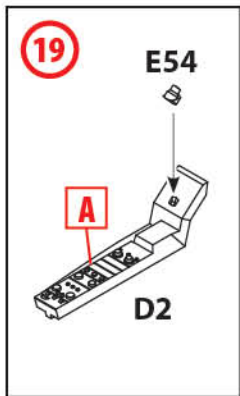
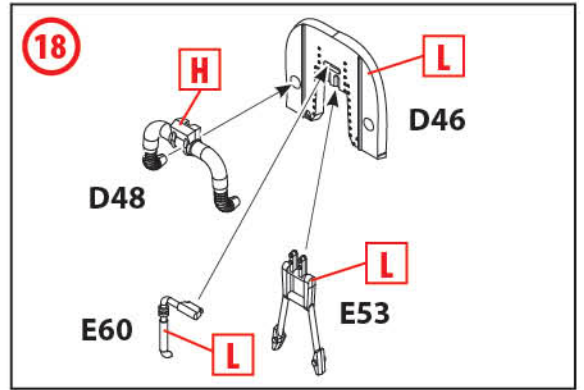
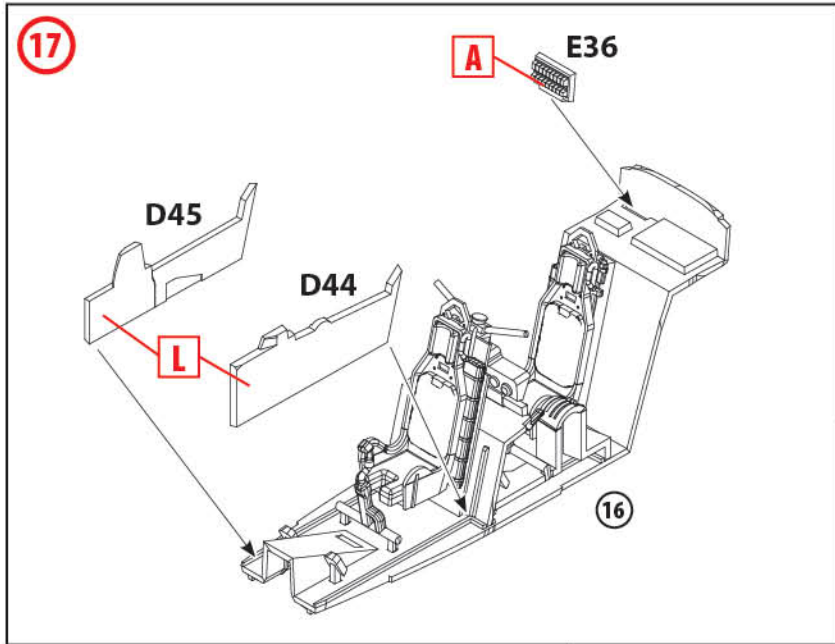

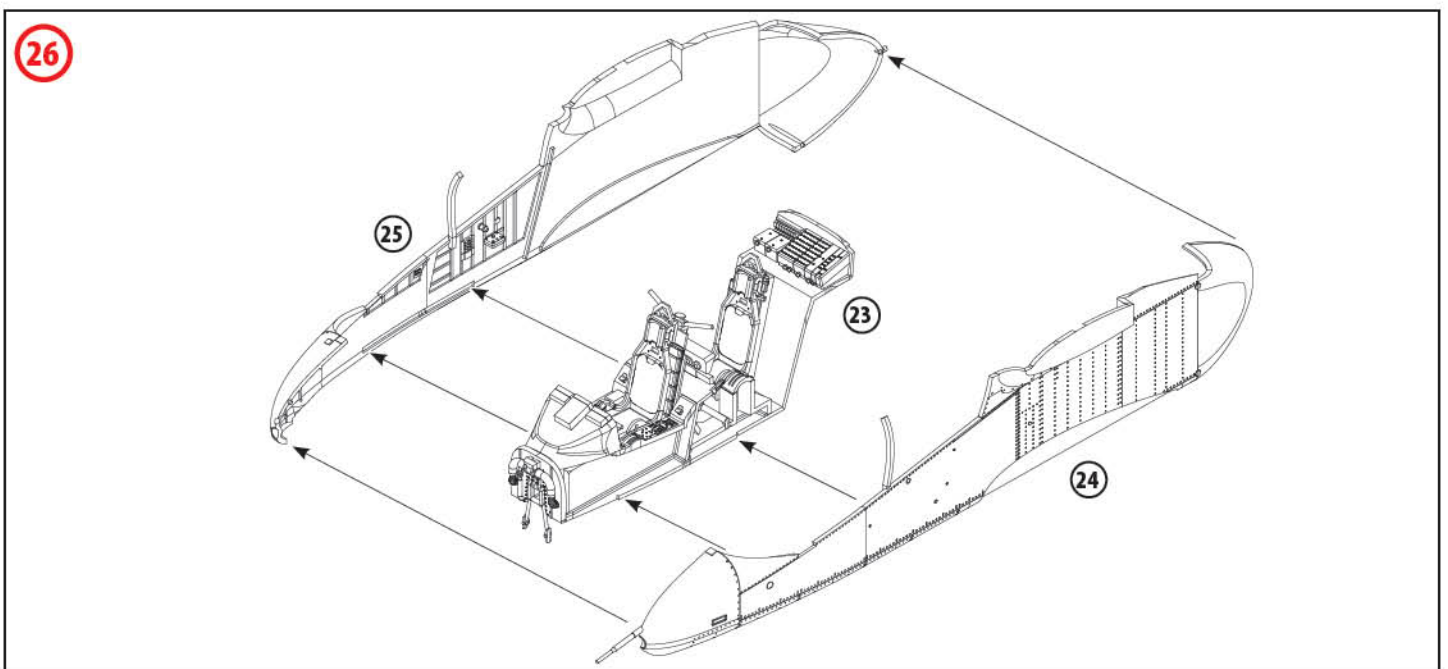
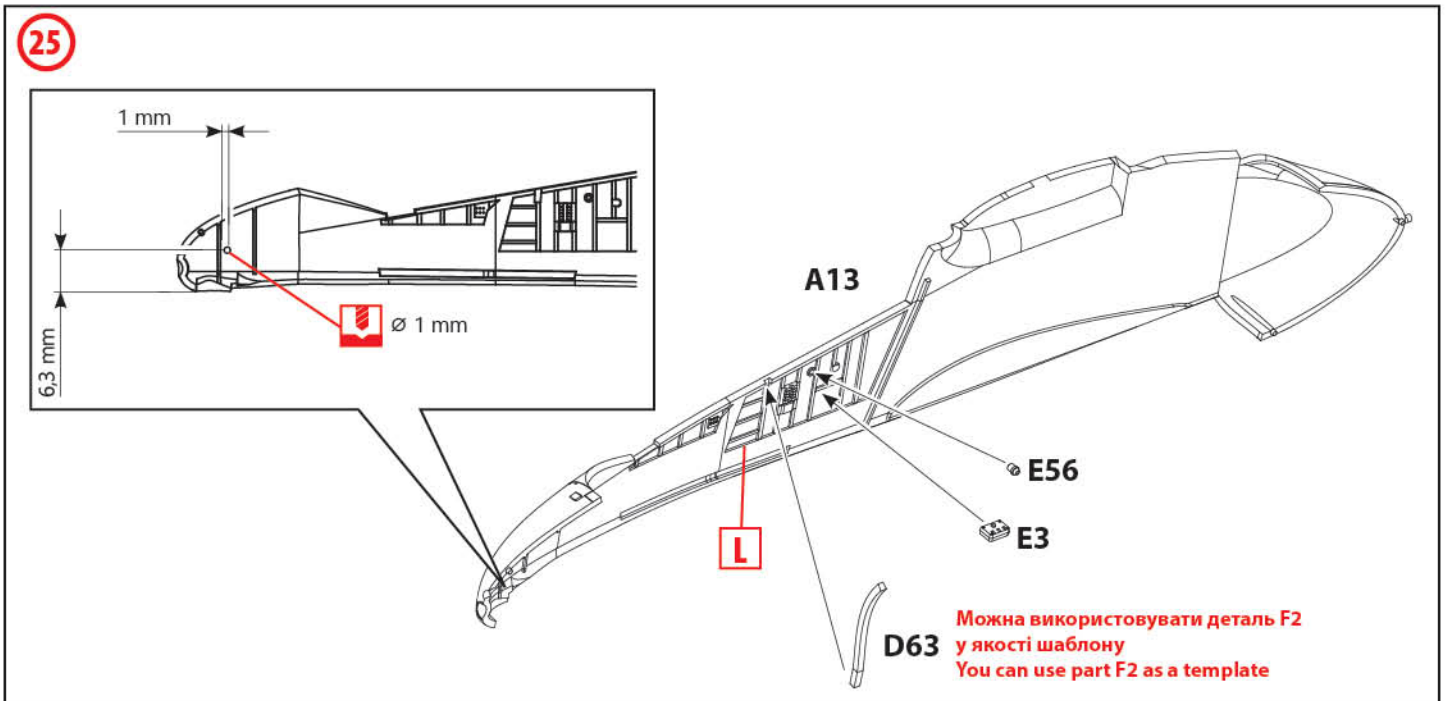
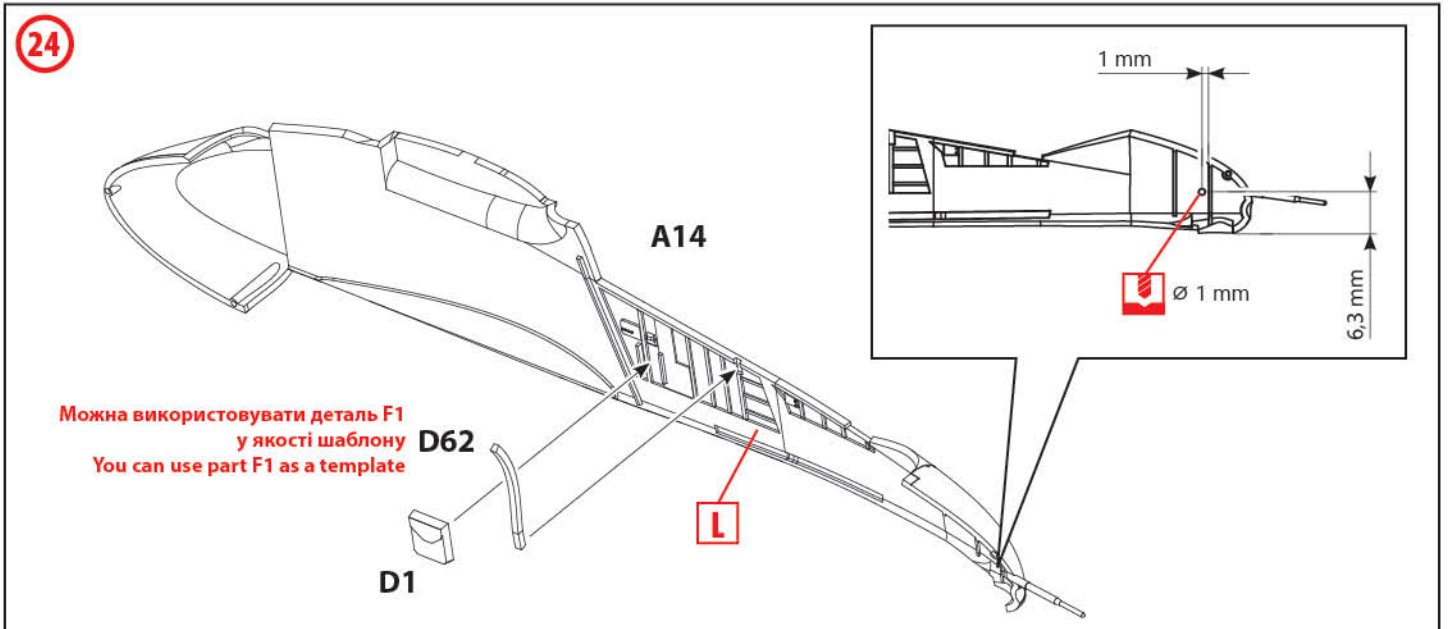



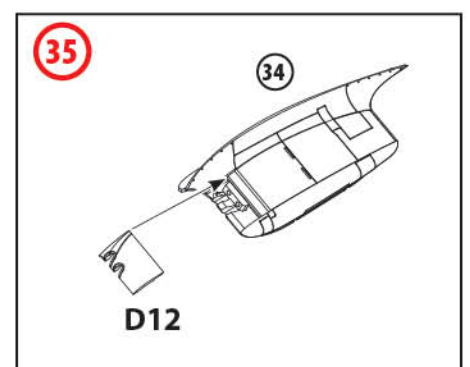
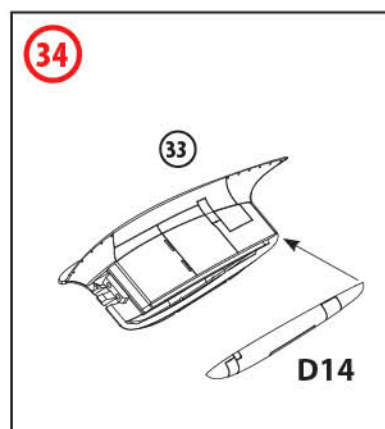
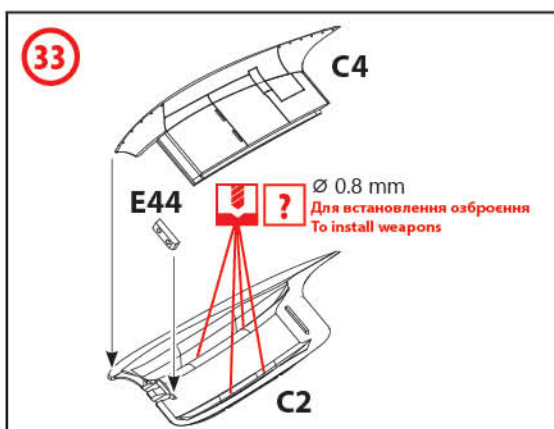
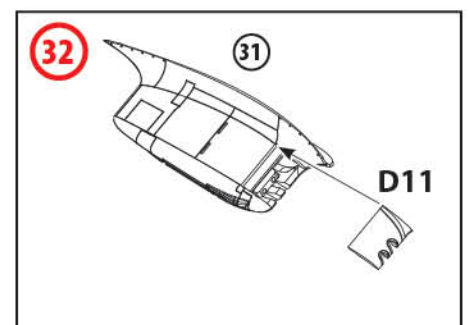
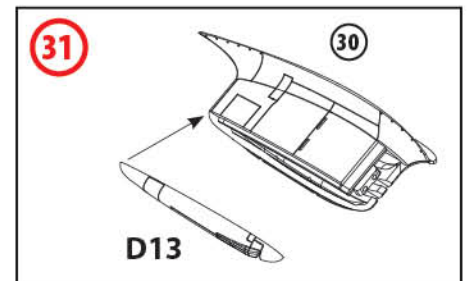
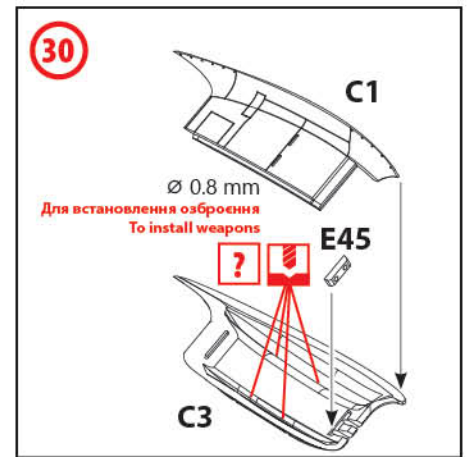
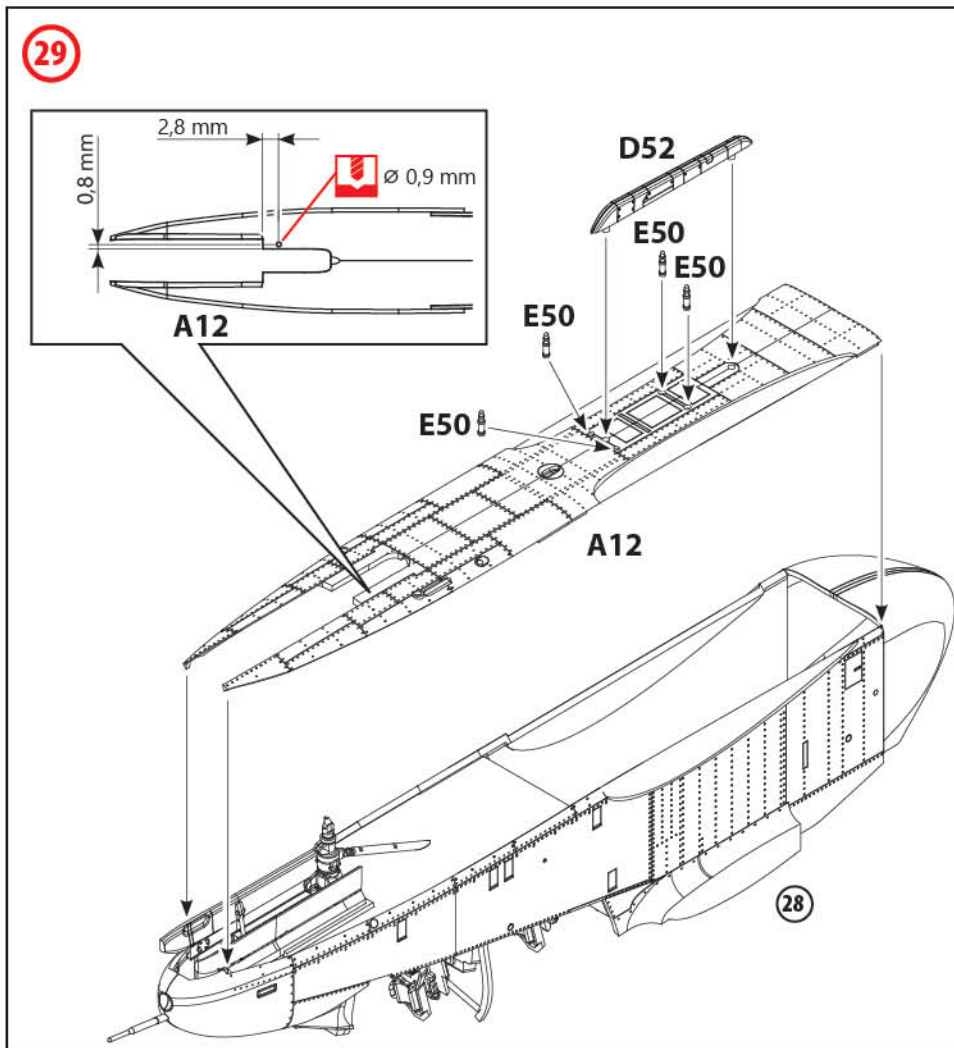
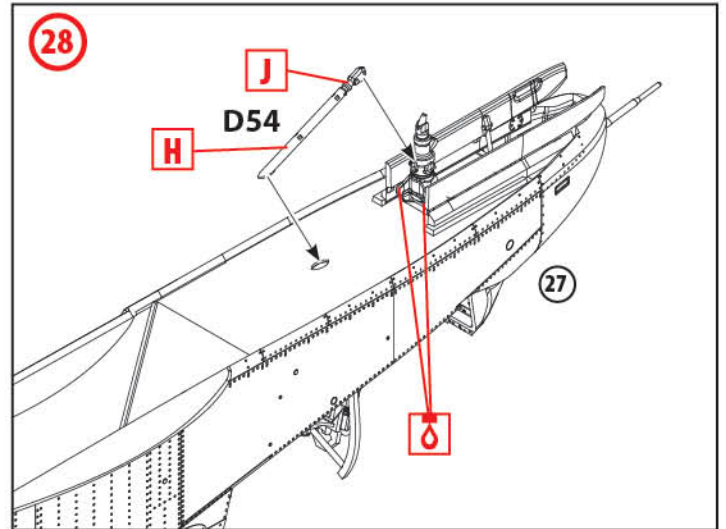
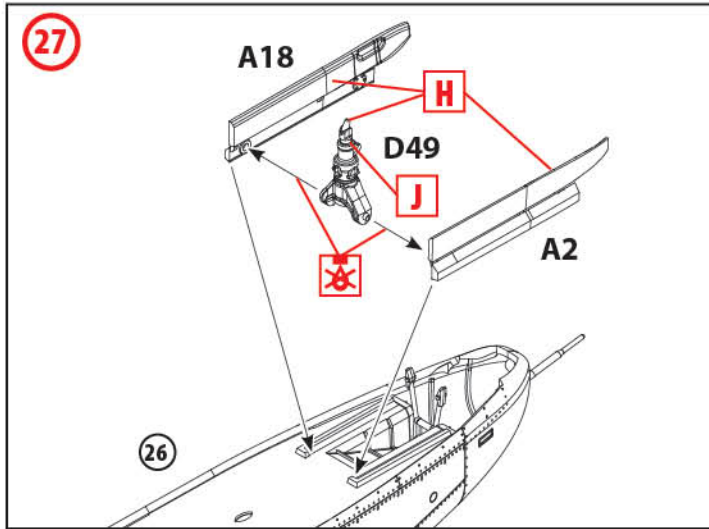

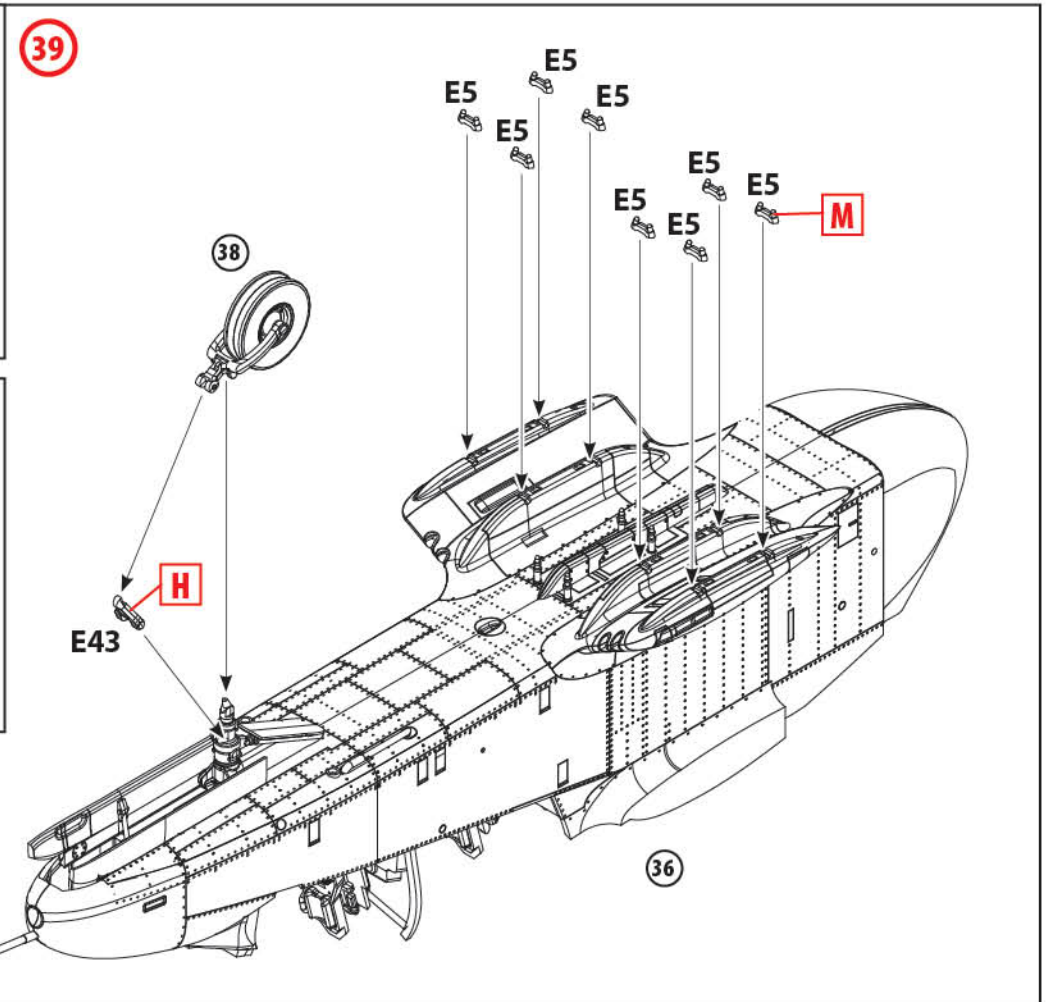
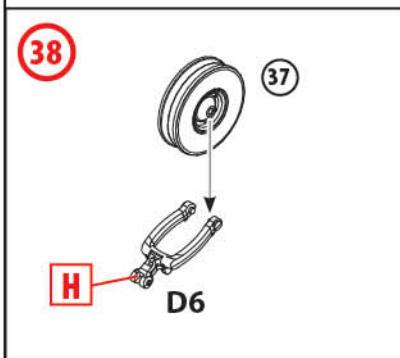
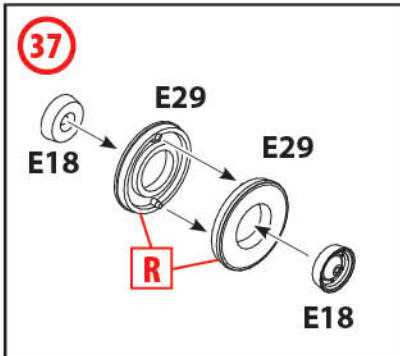
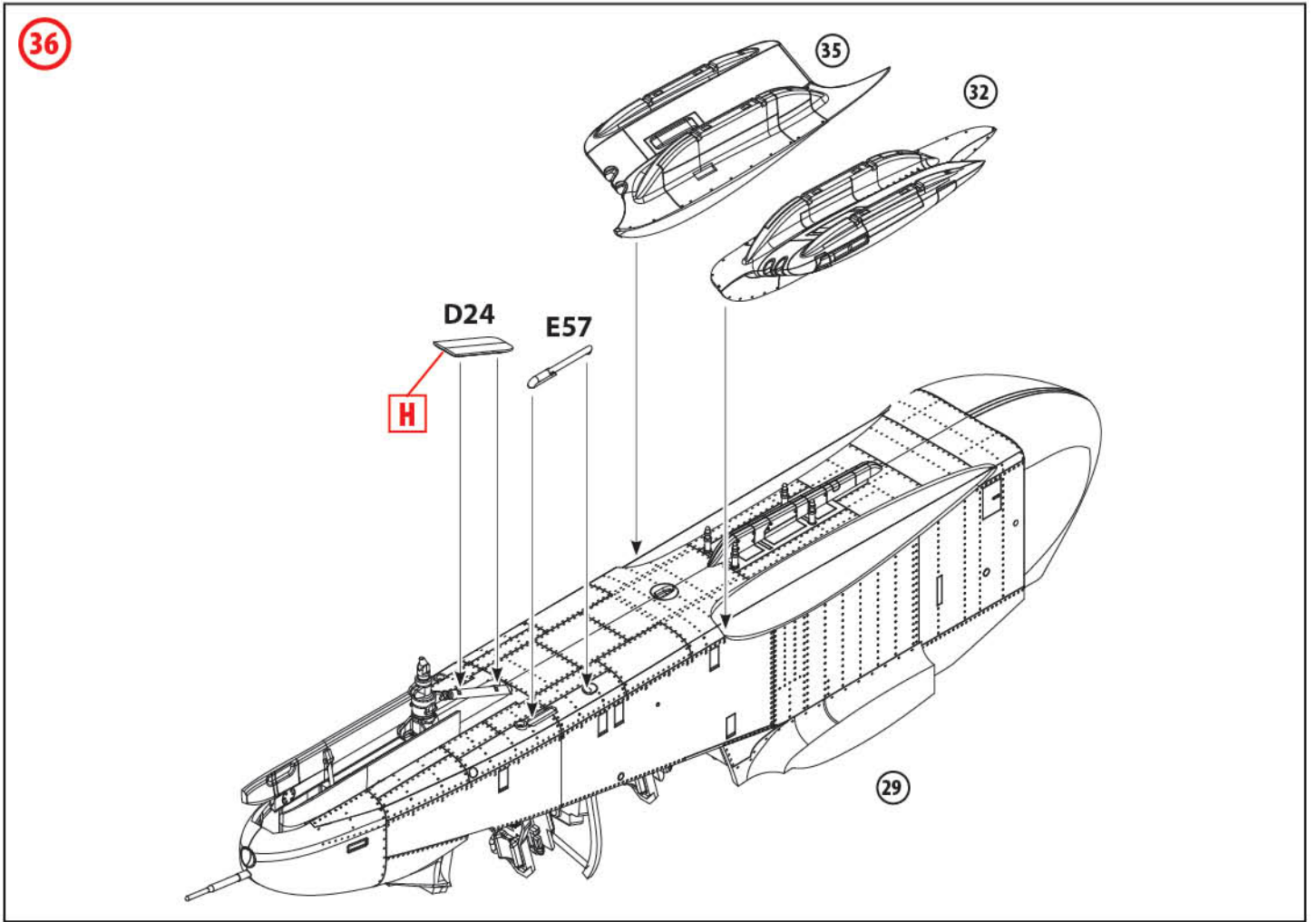

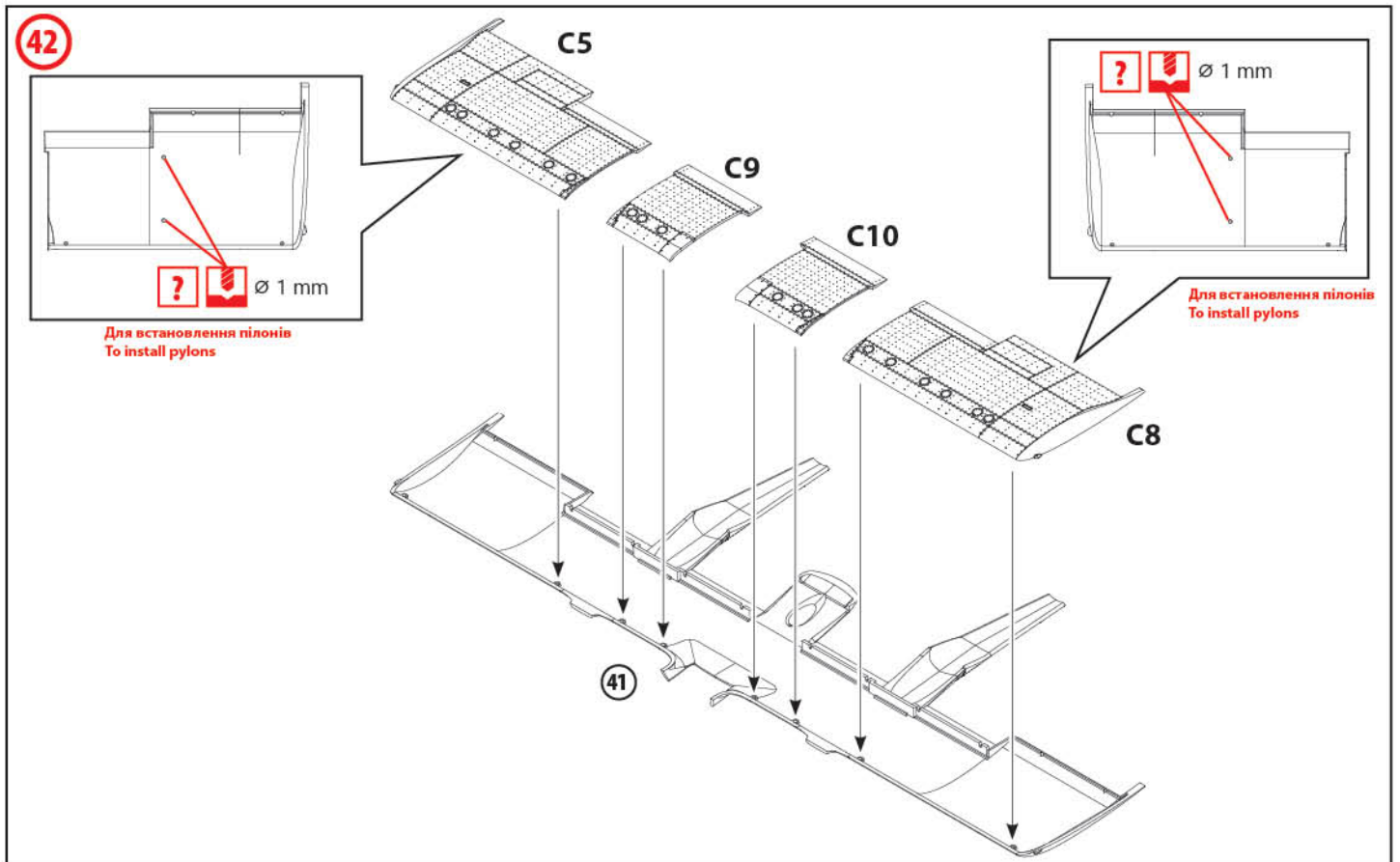
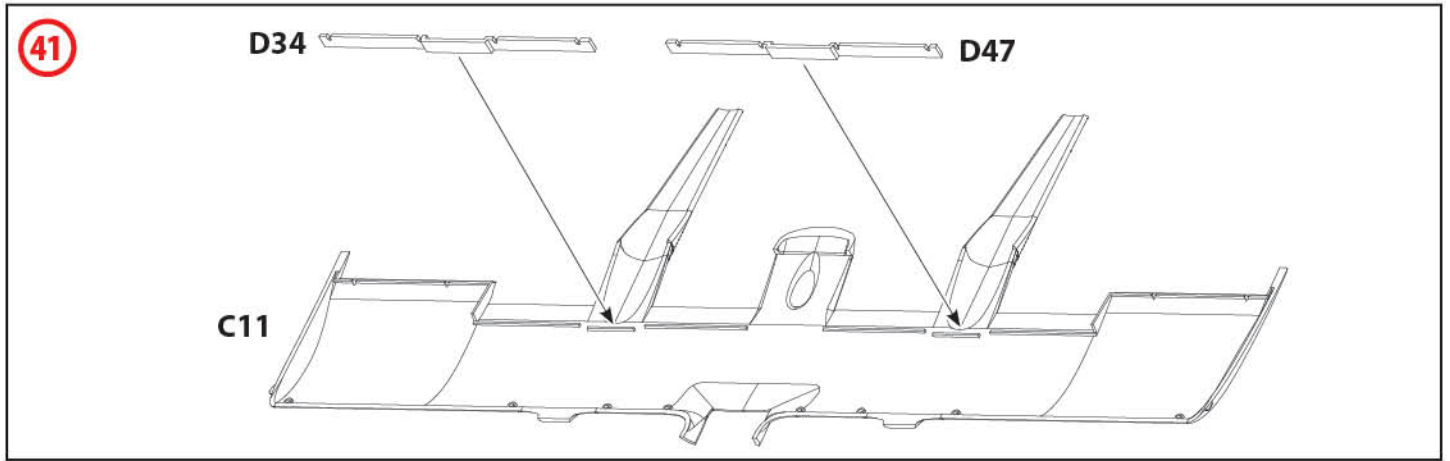
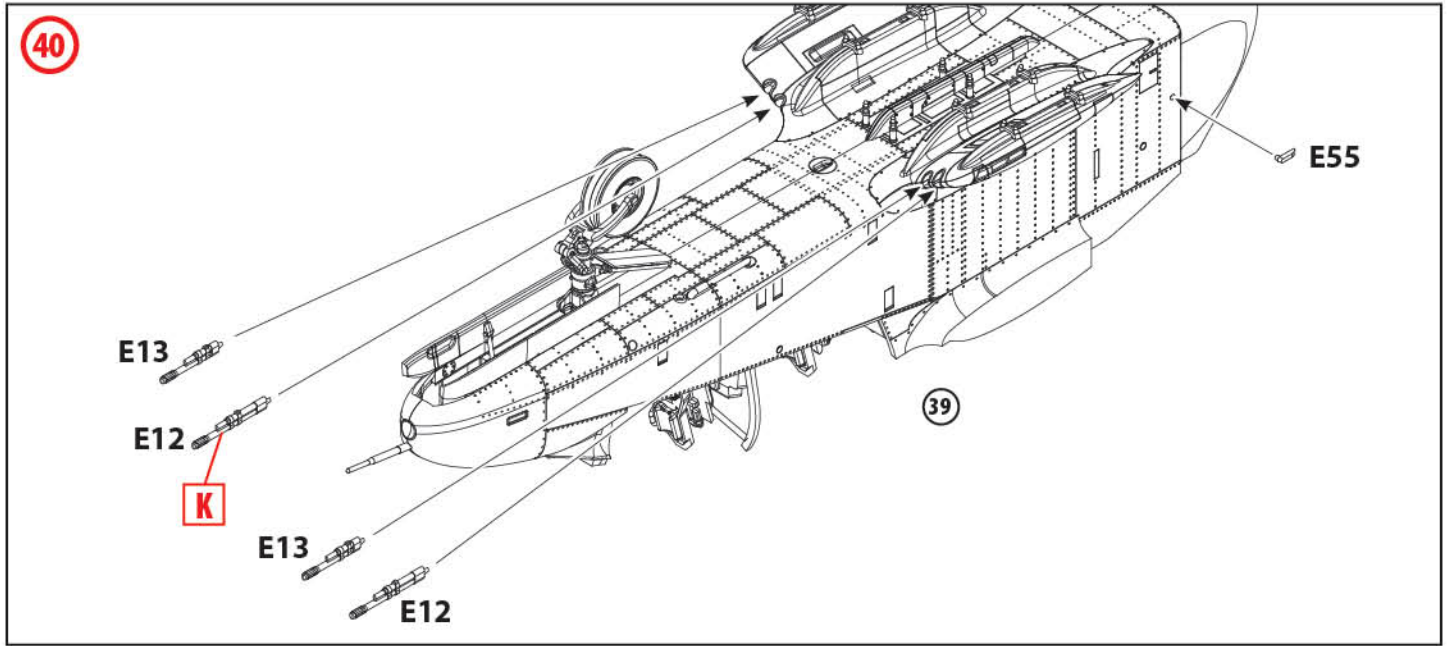

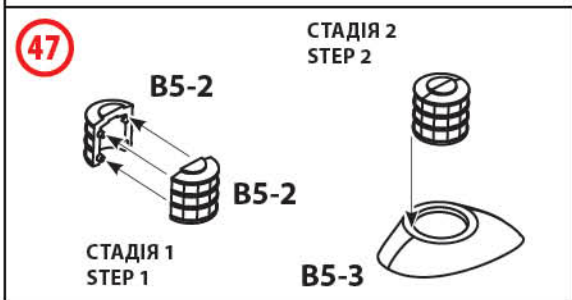
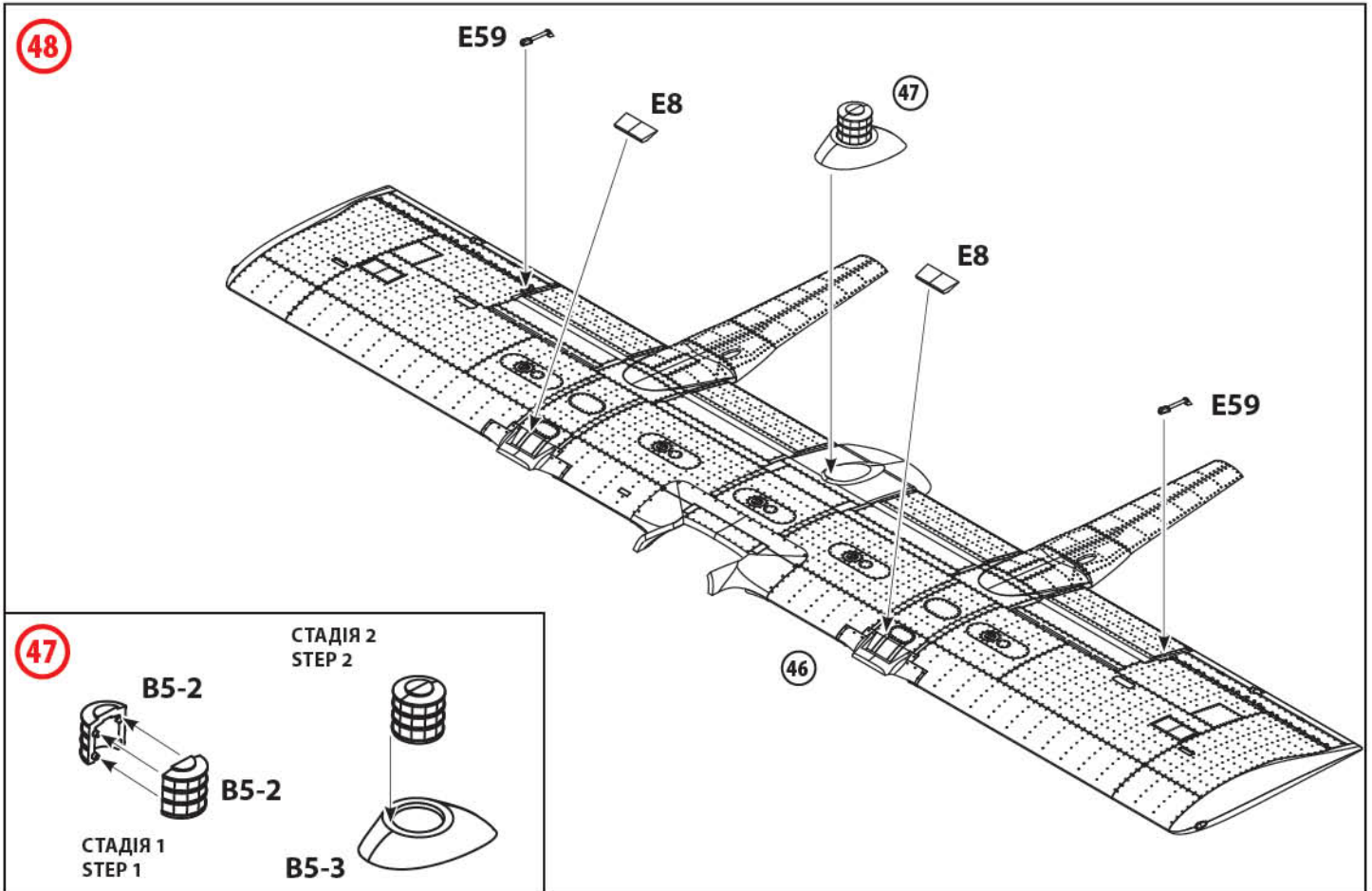
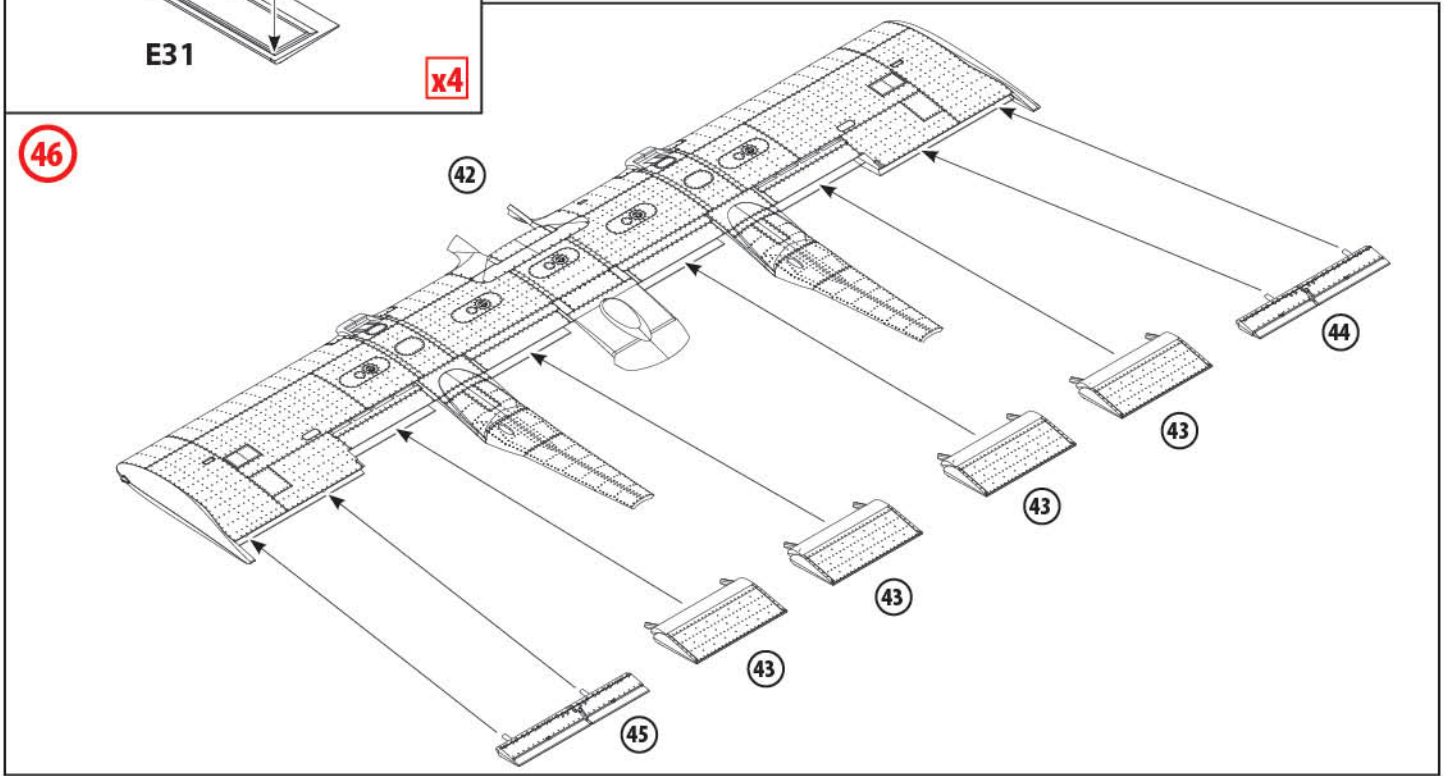
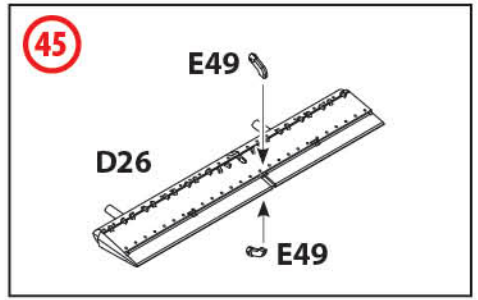
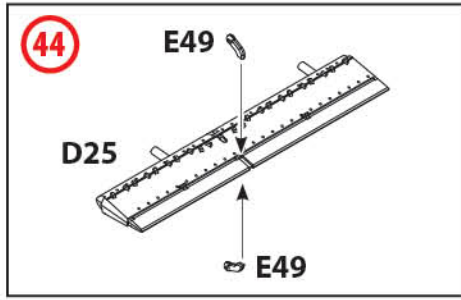
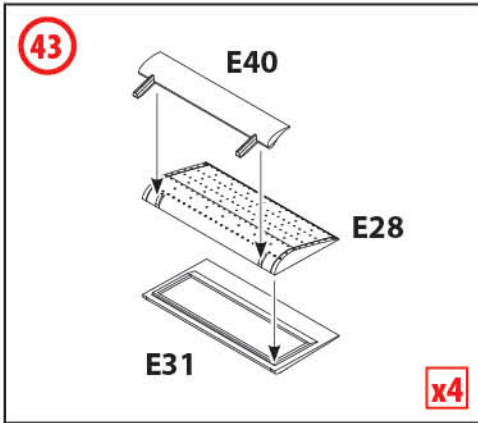

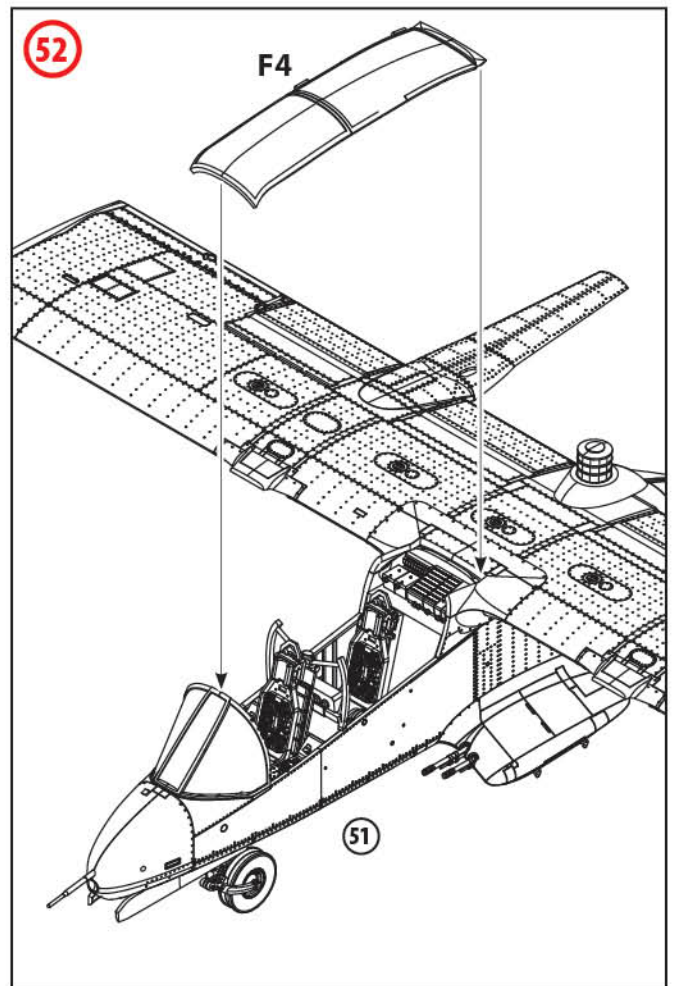
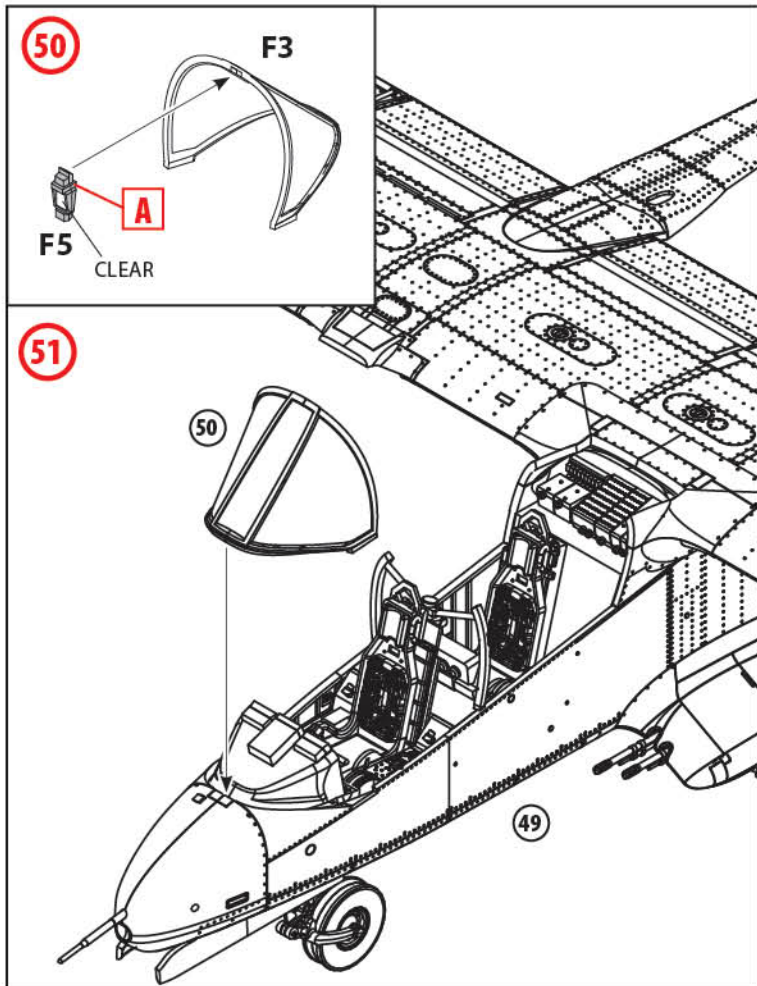
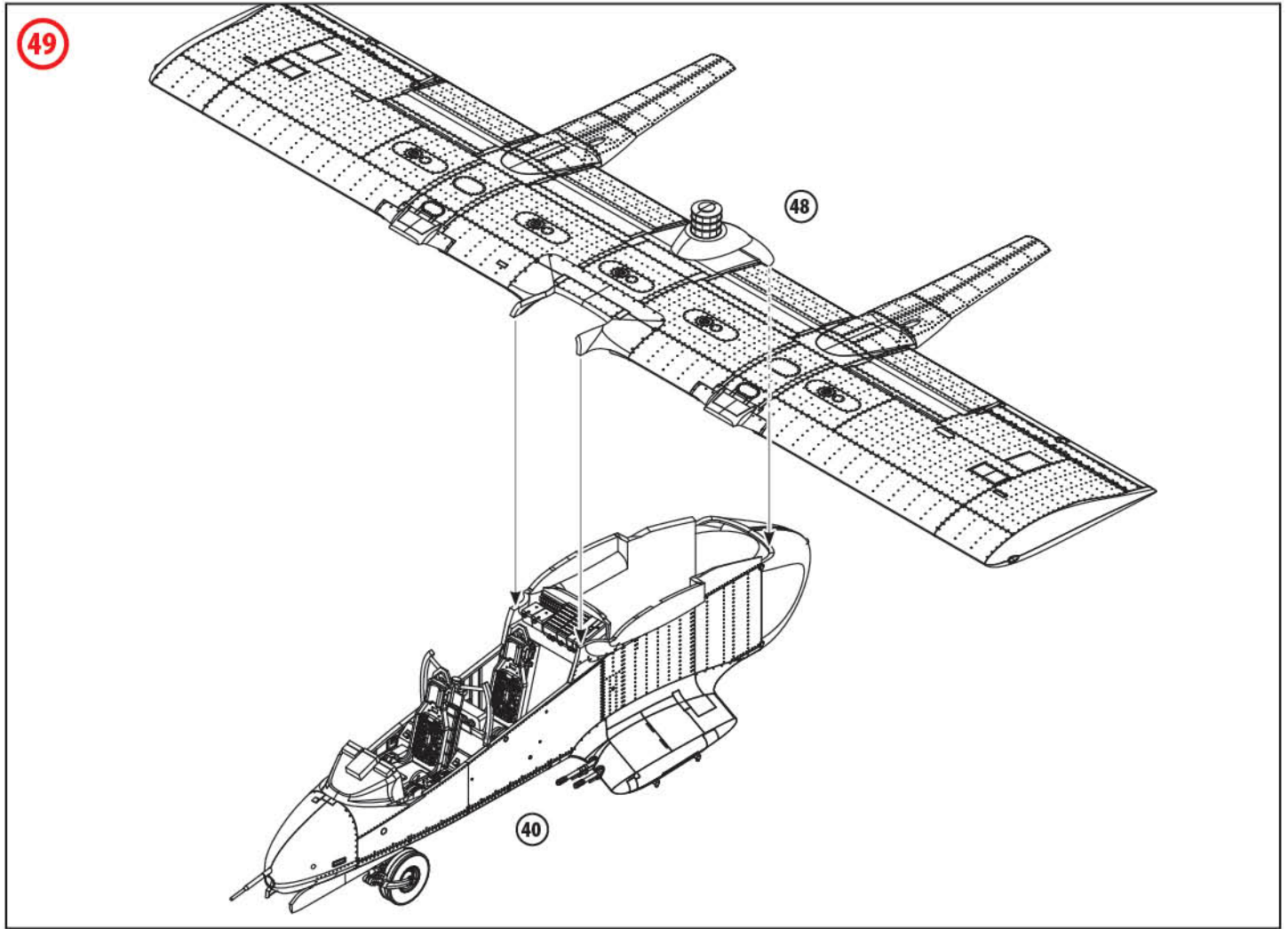

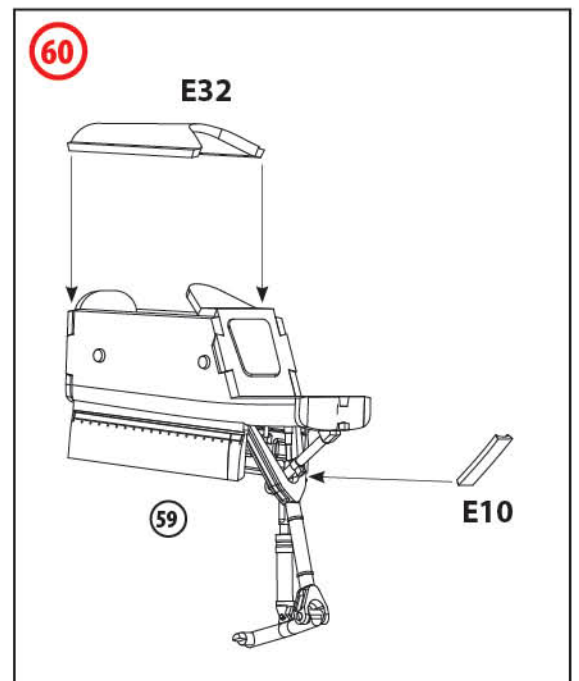
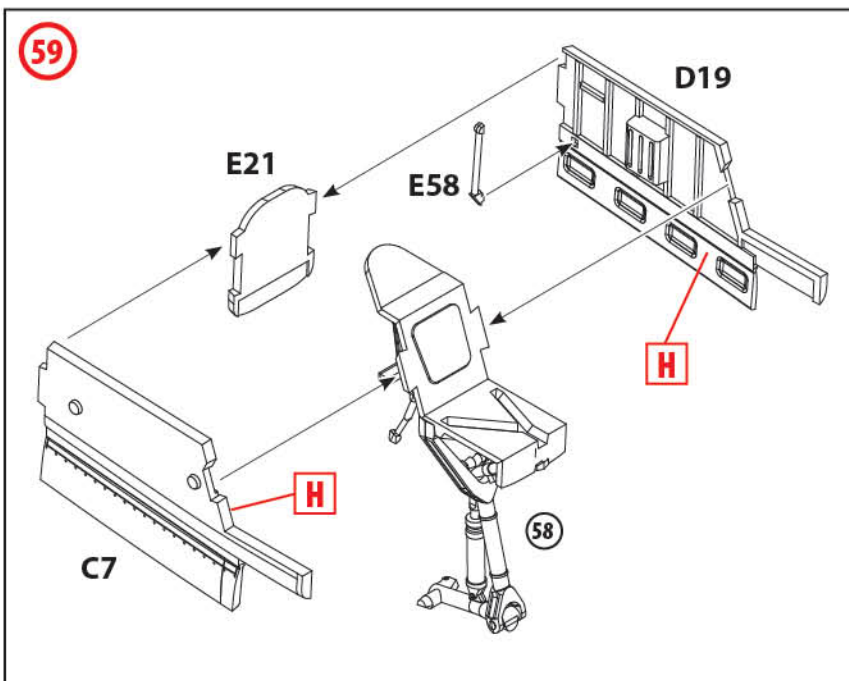
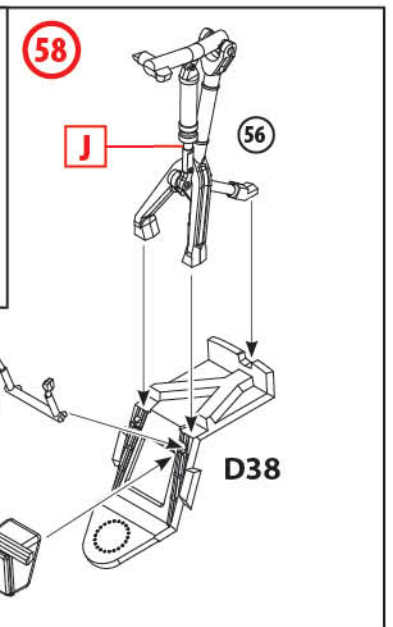
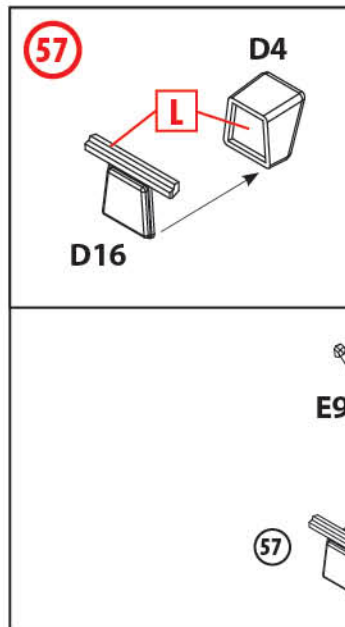
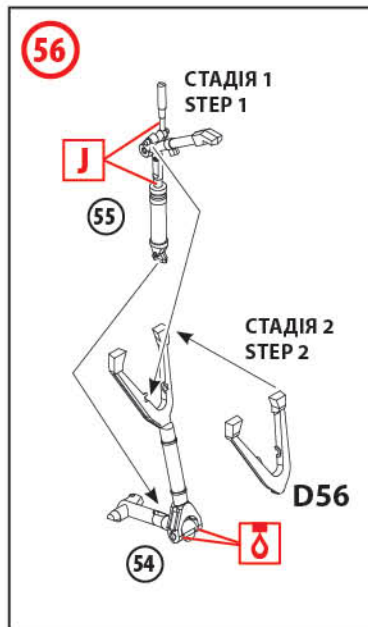
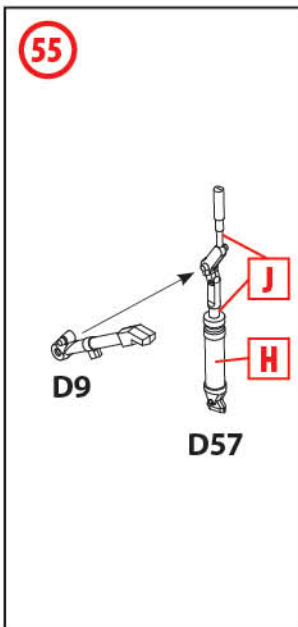
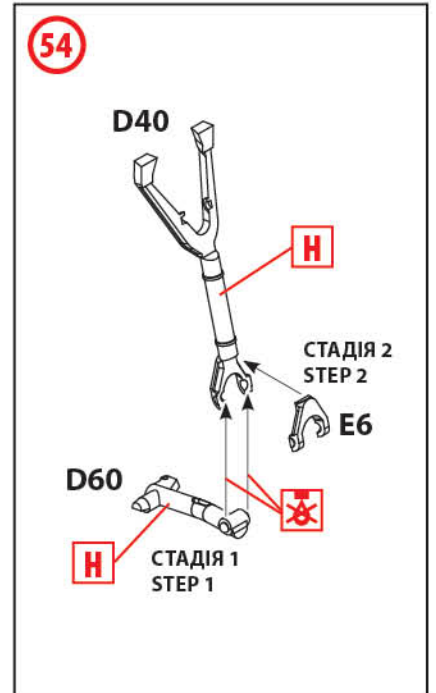
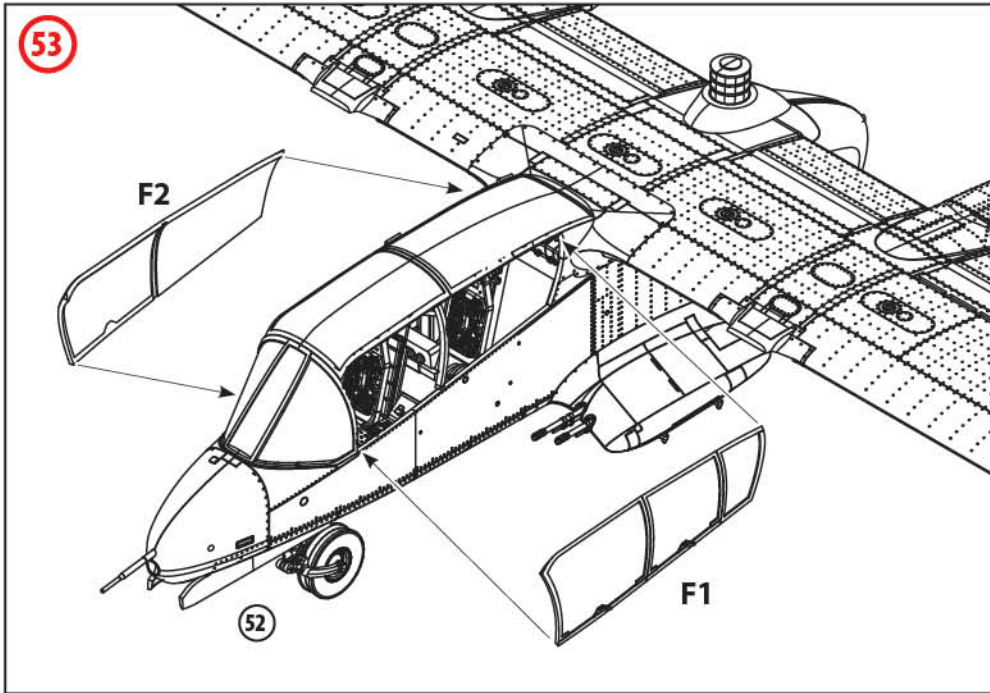

61

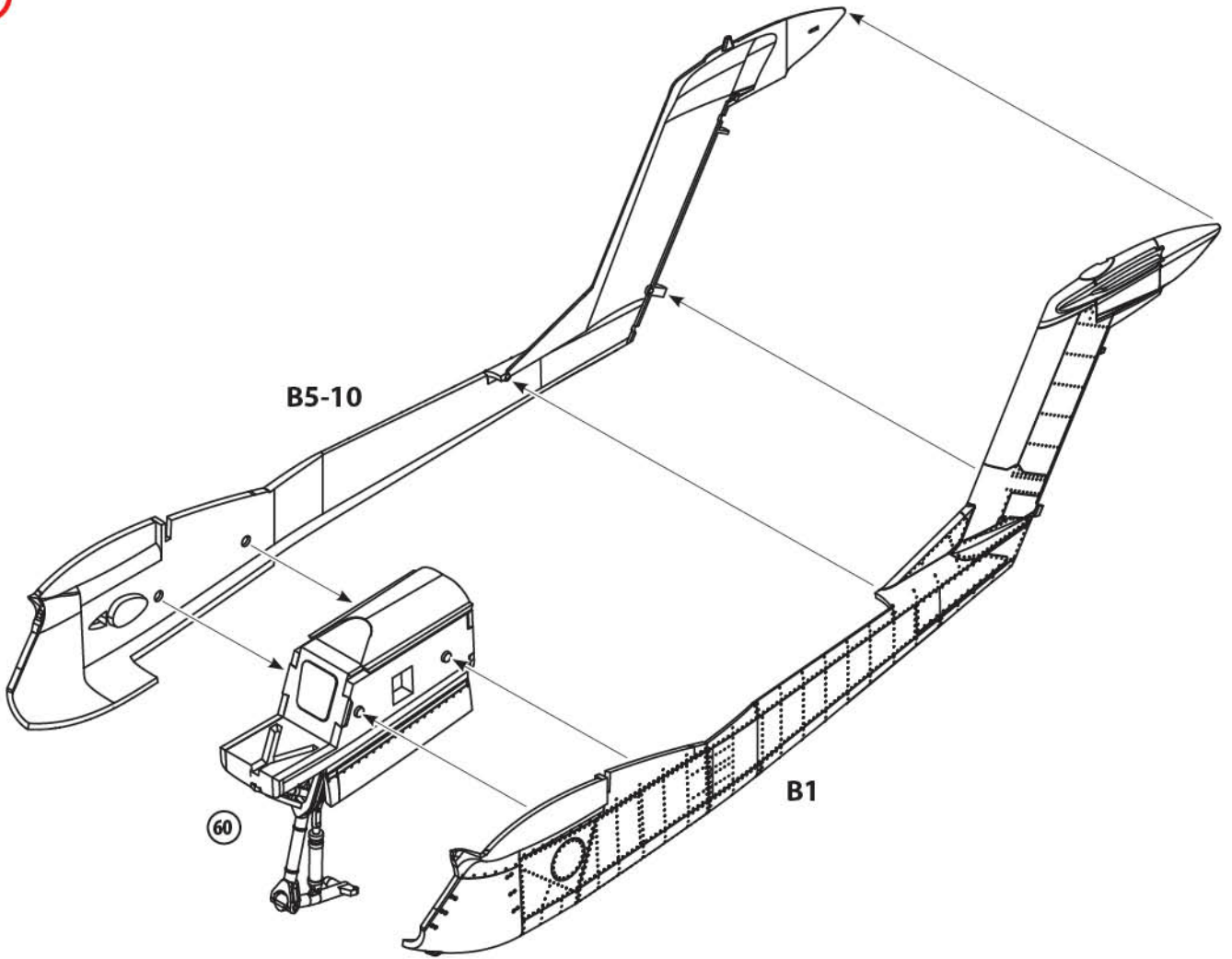

62

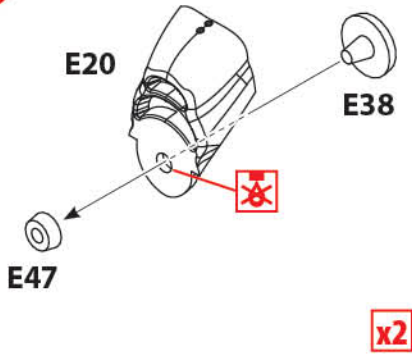

63

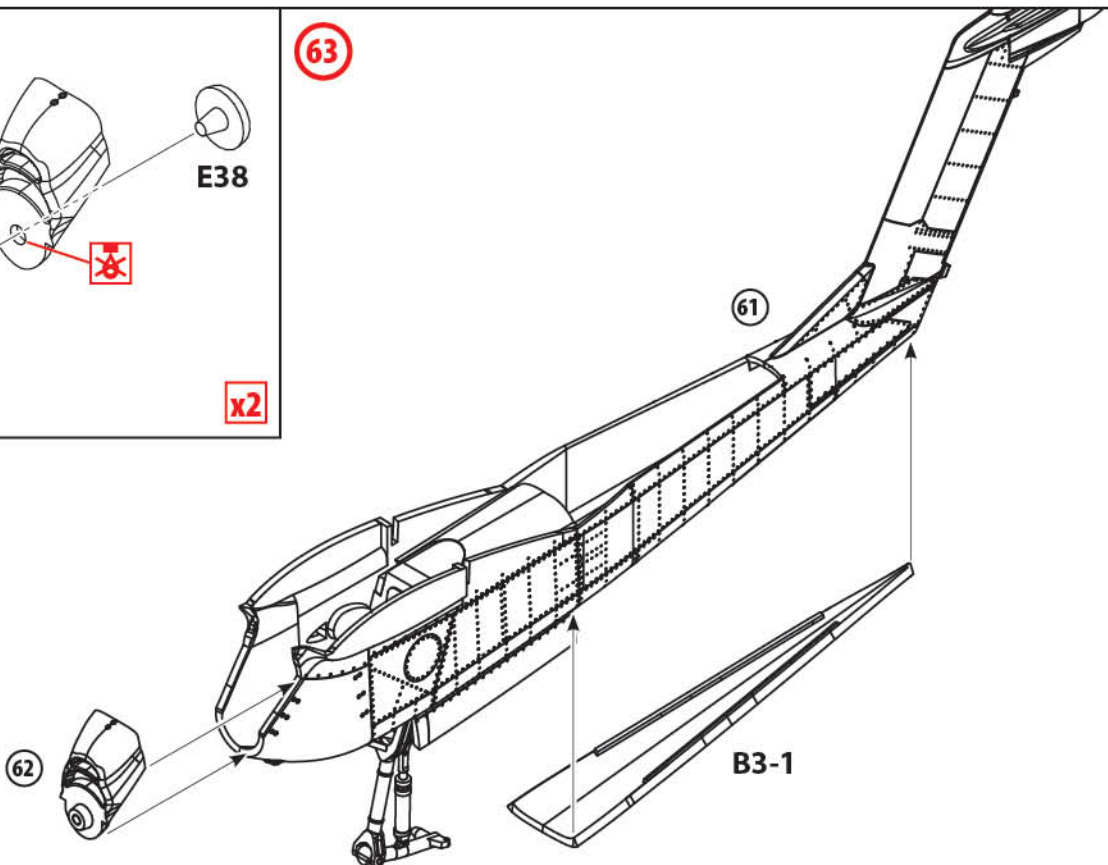

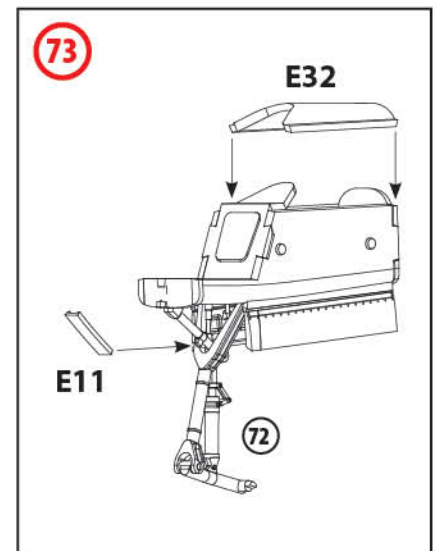
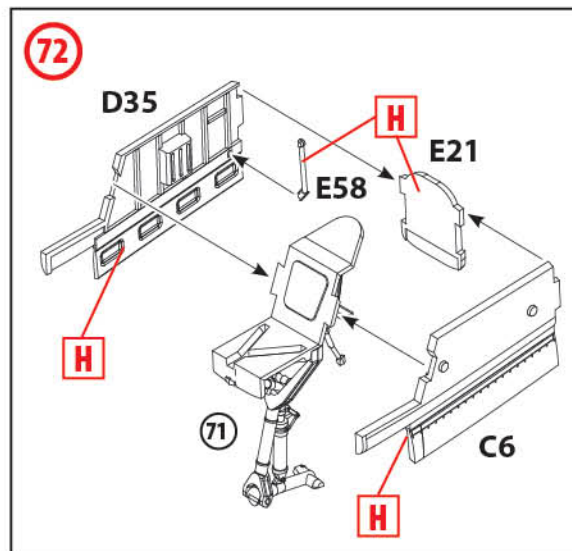
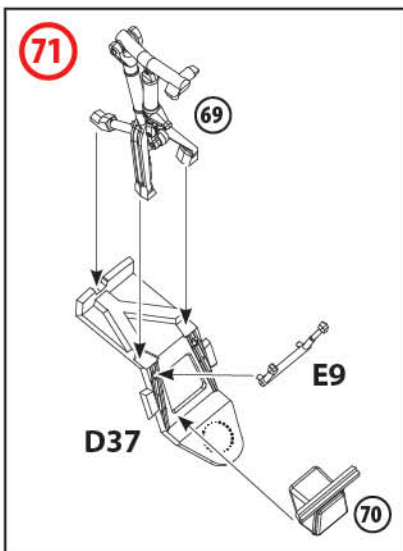
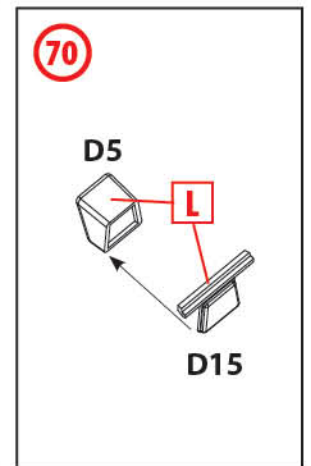
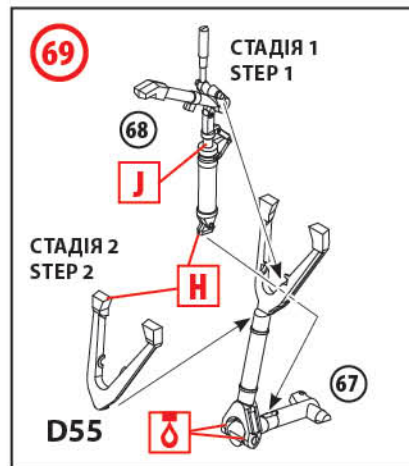
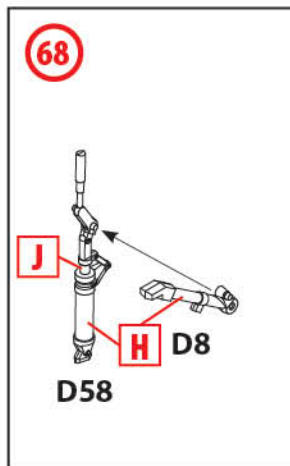
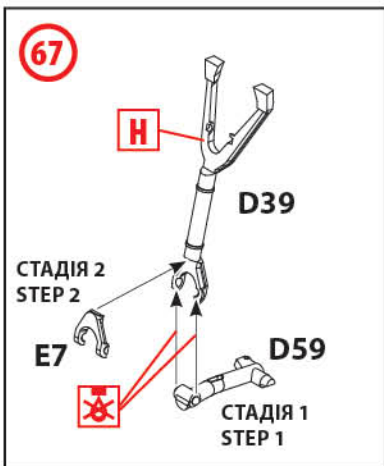
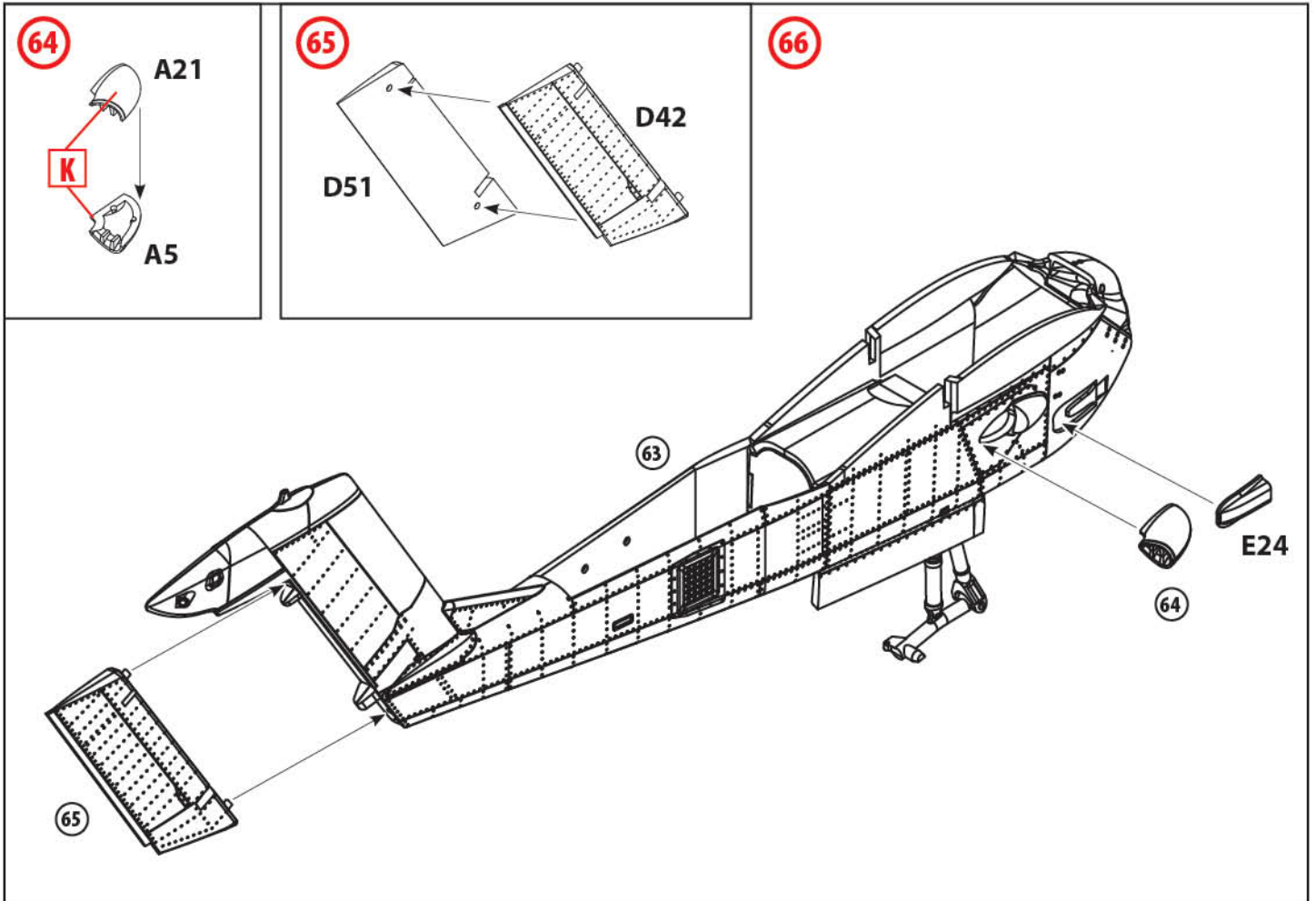



74

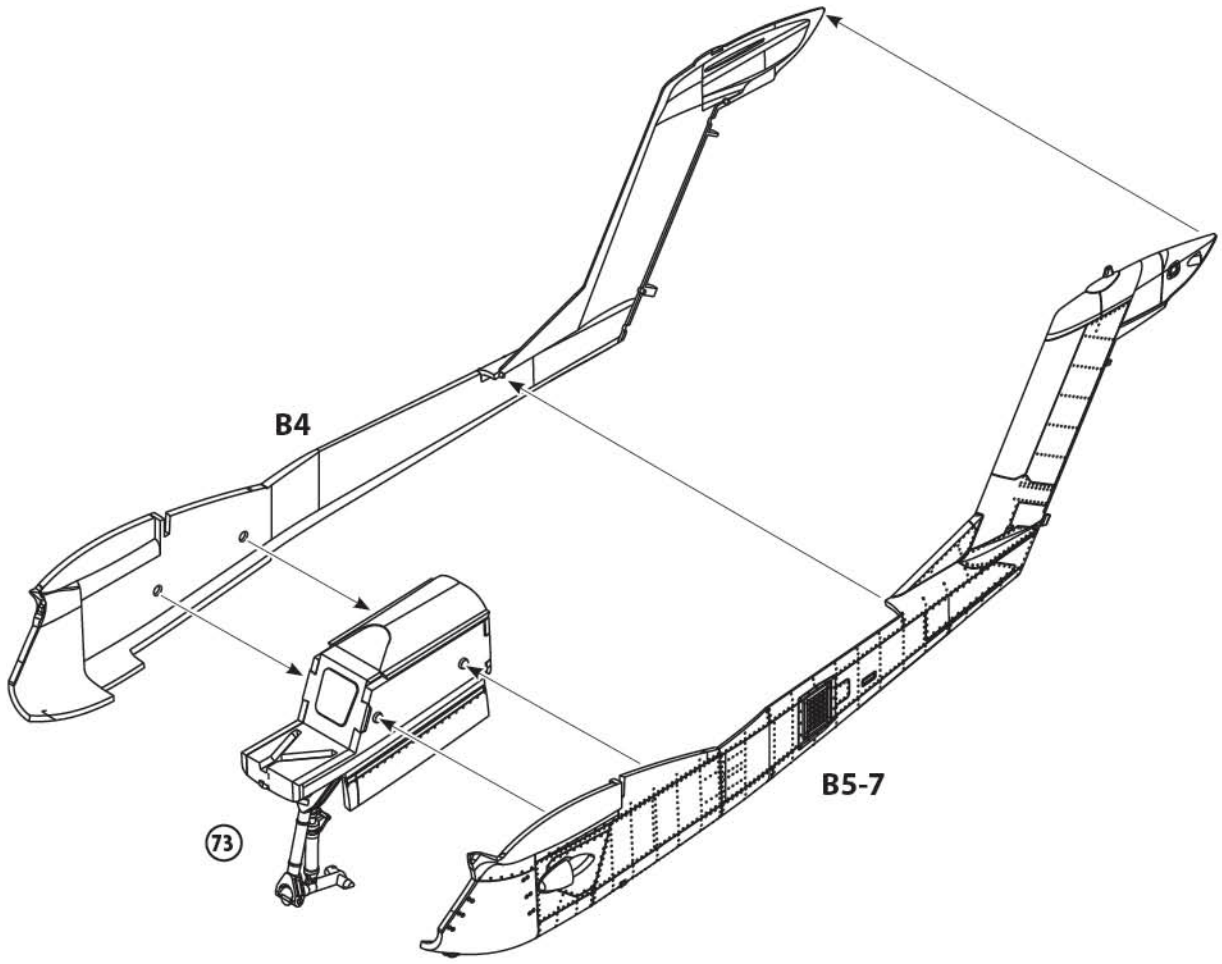

75

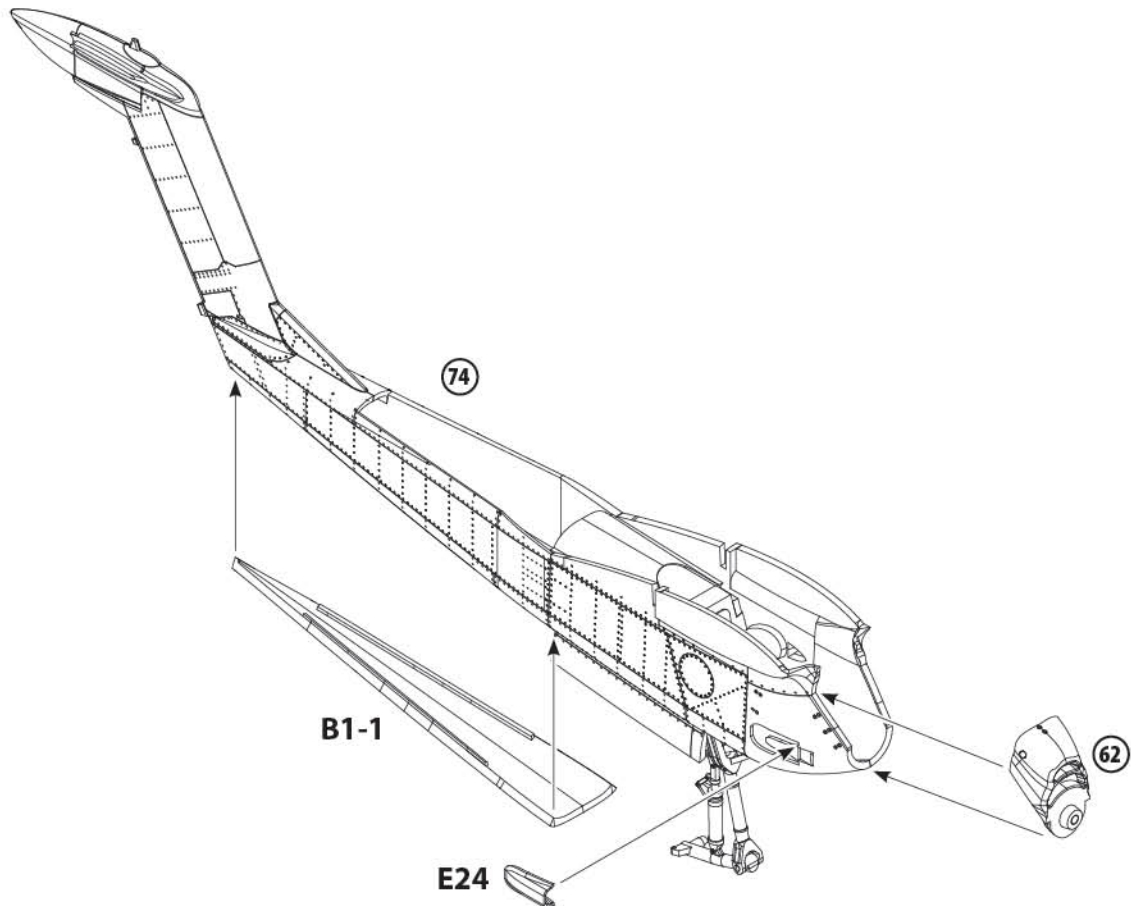

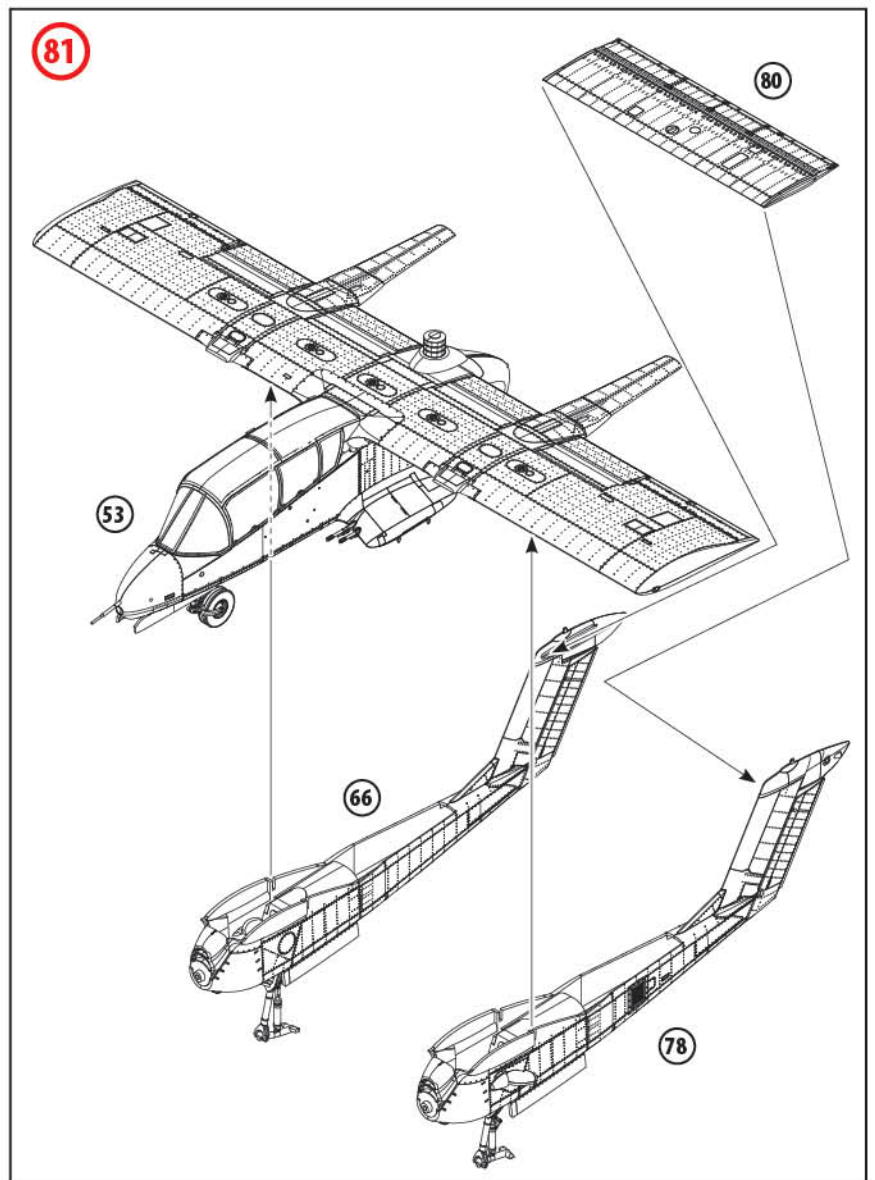
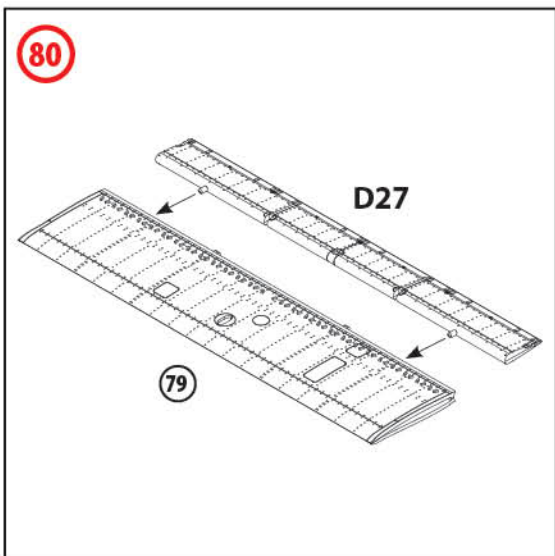
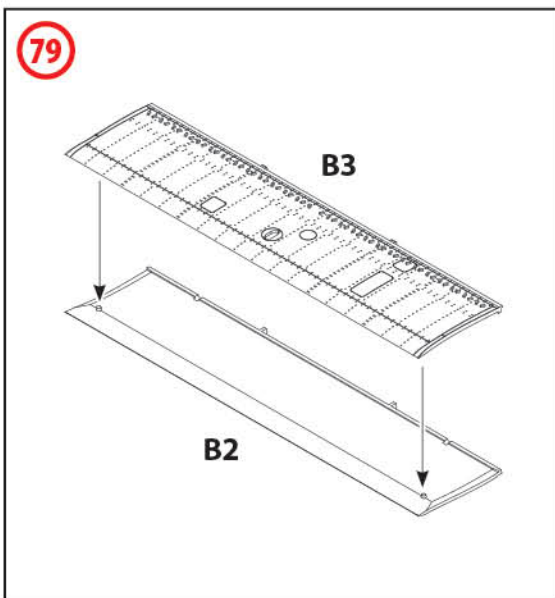
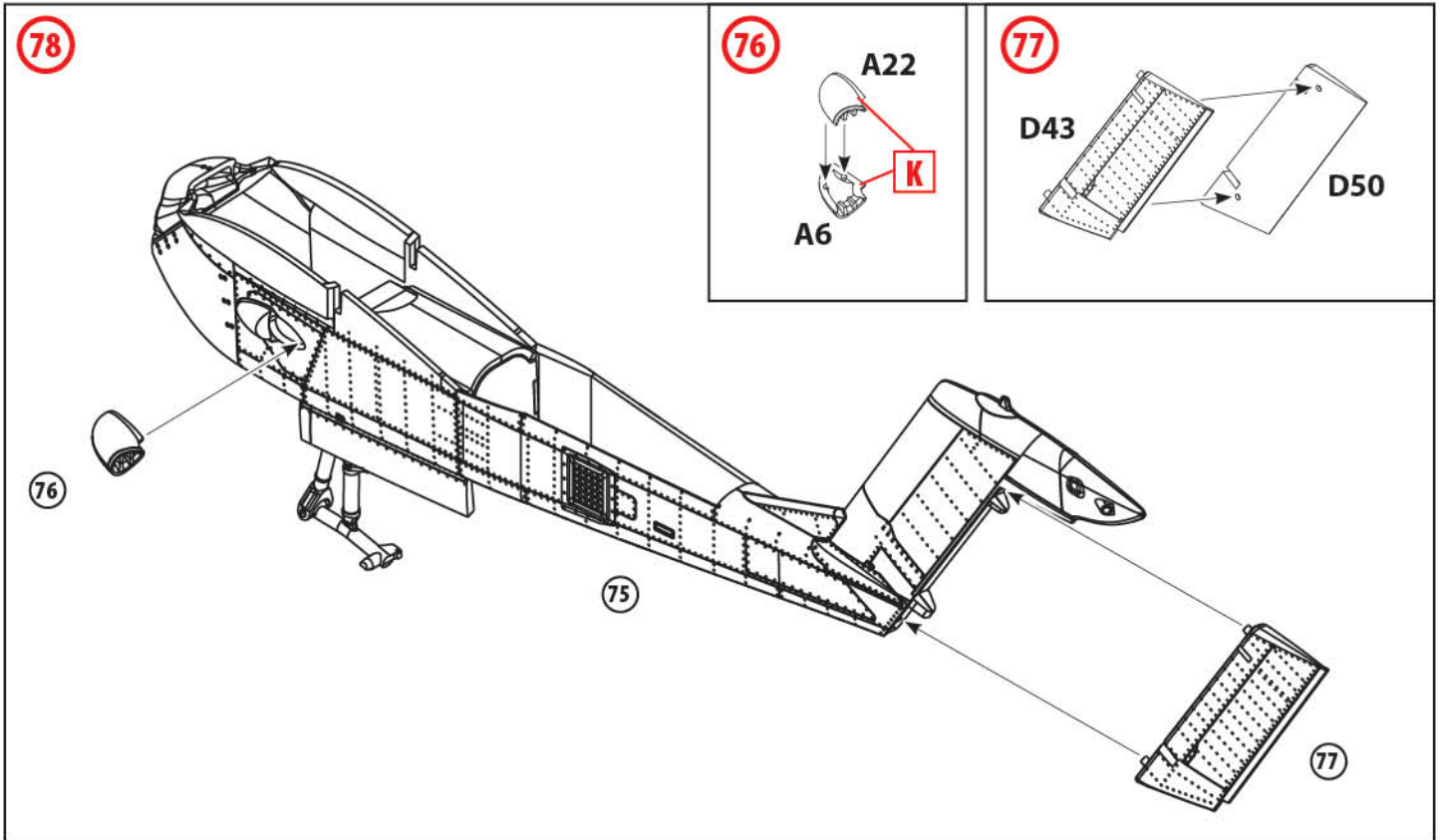

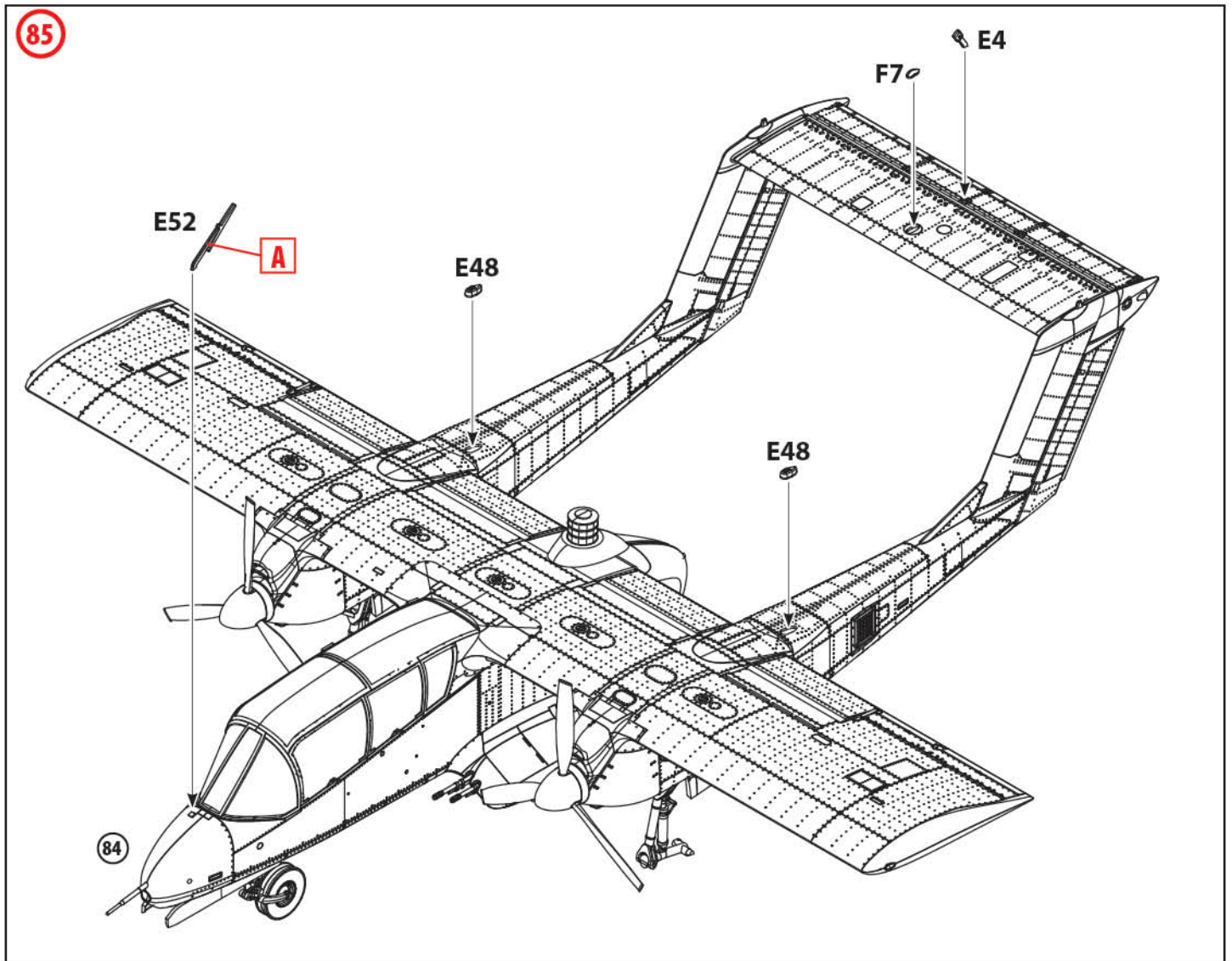
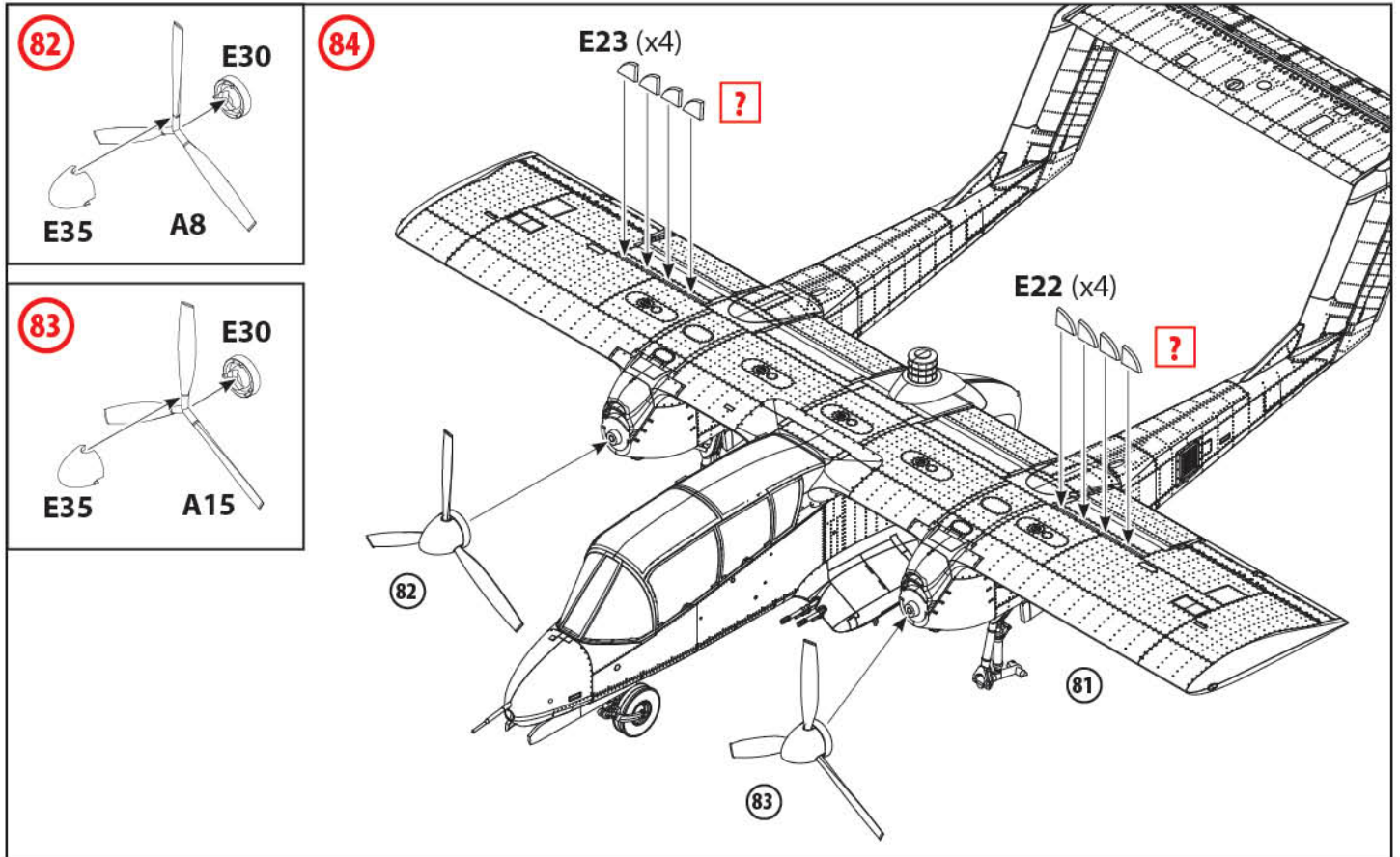

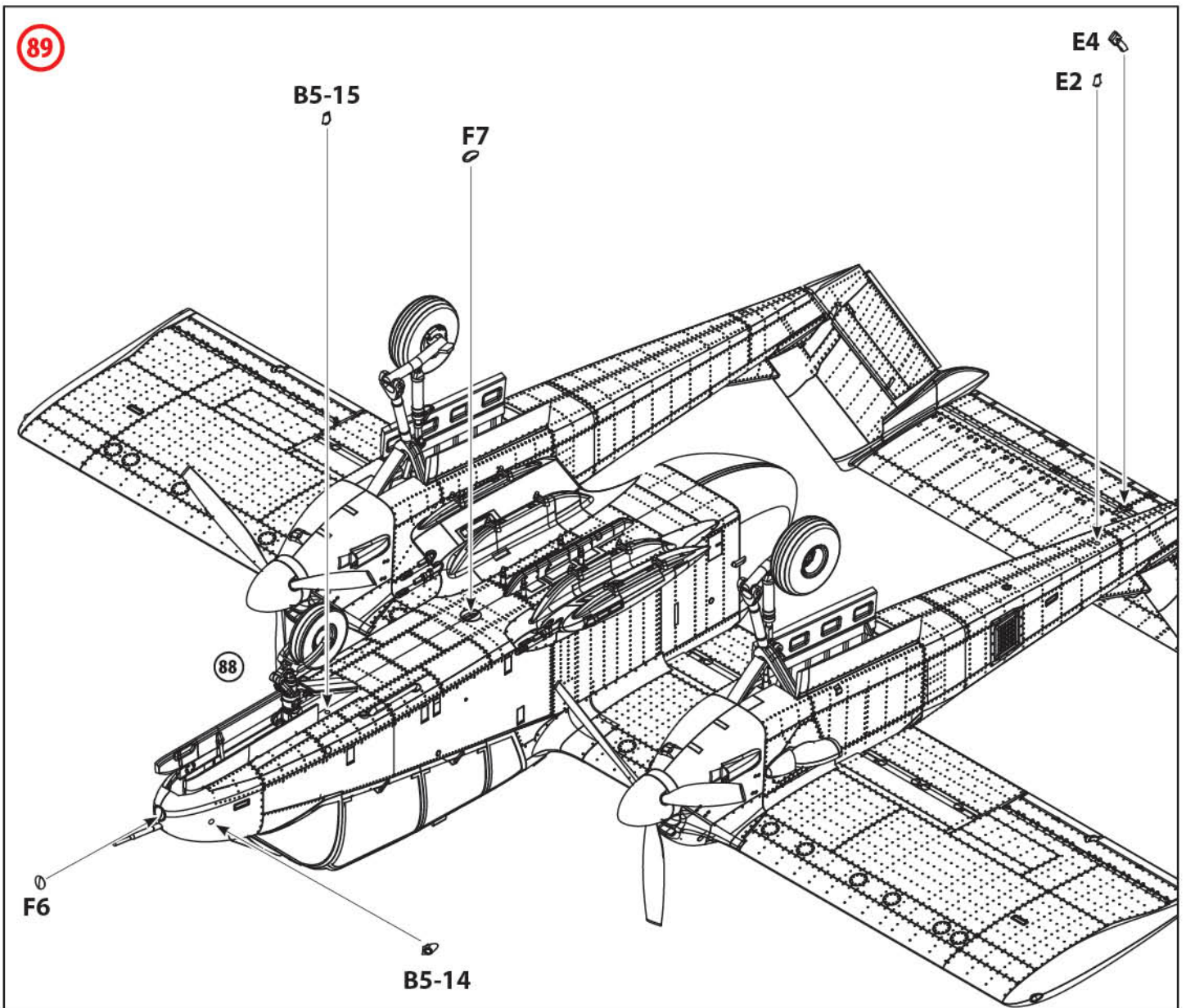
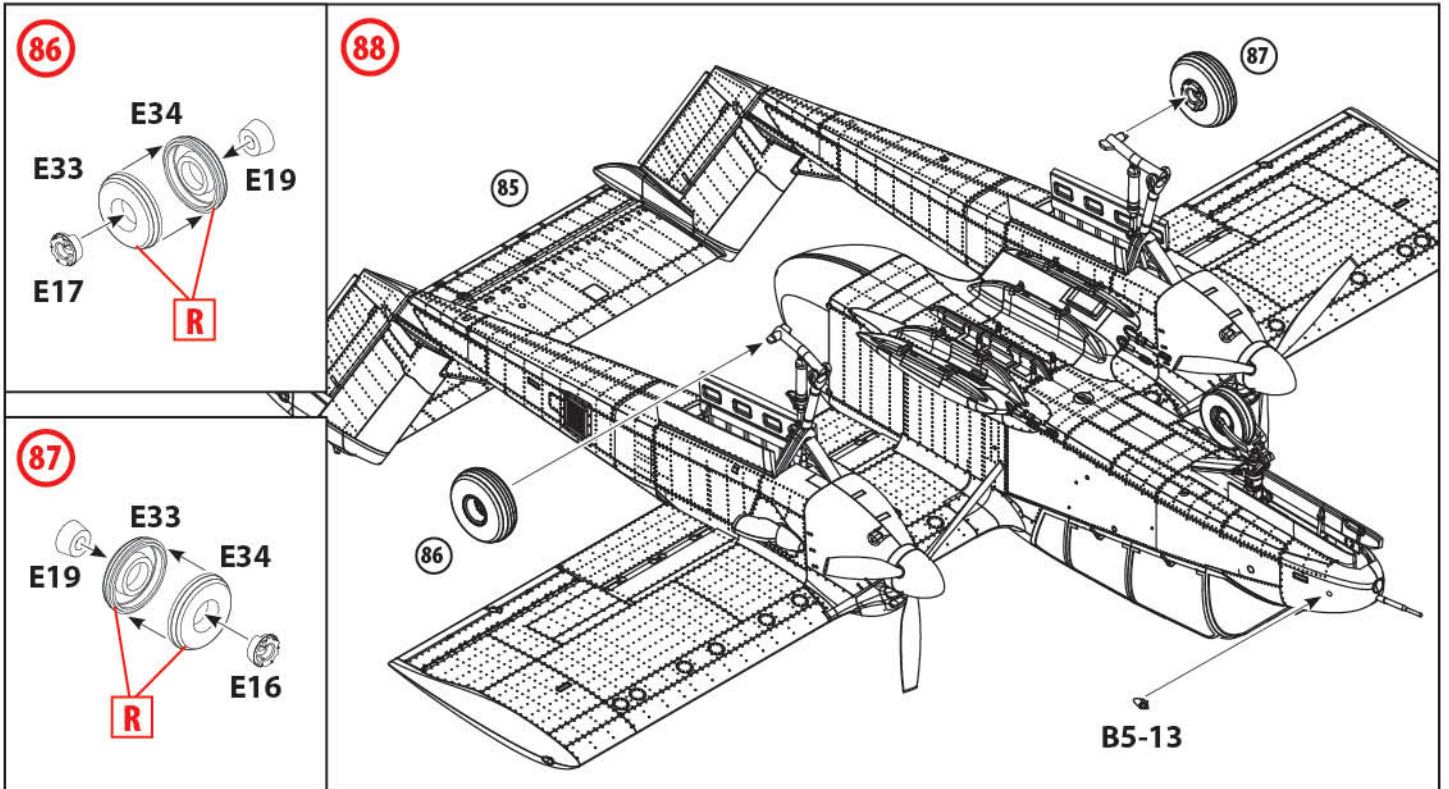

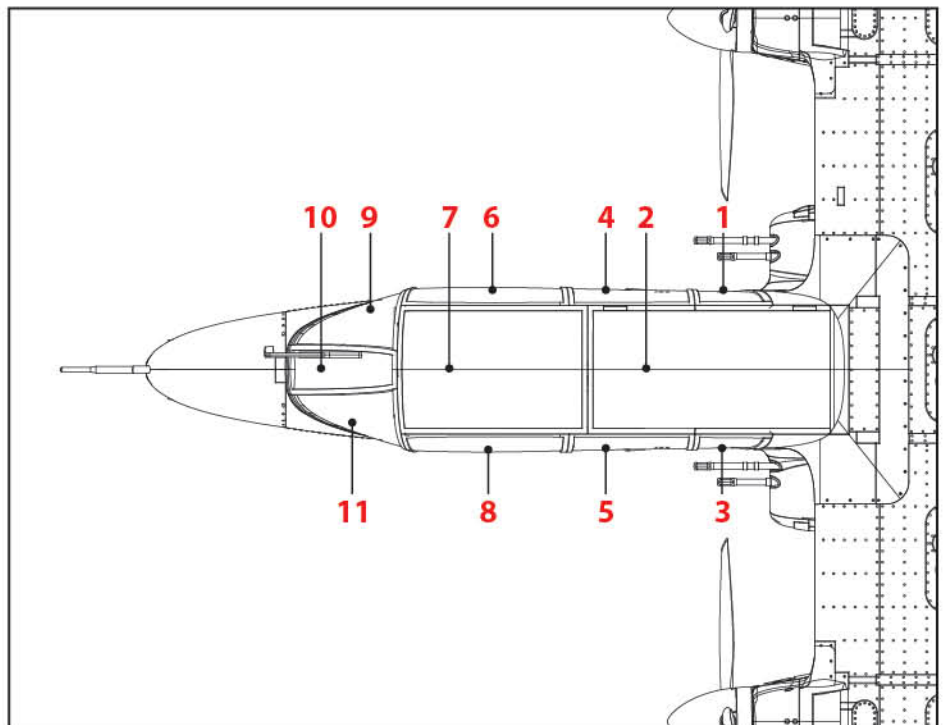
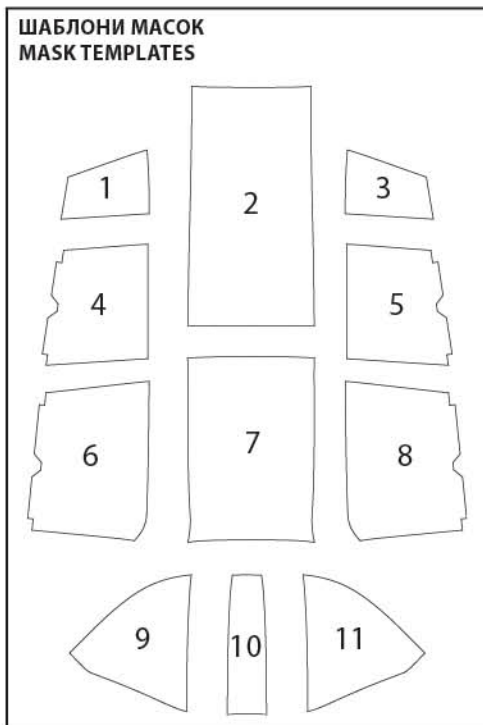
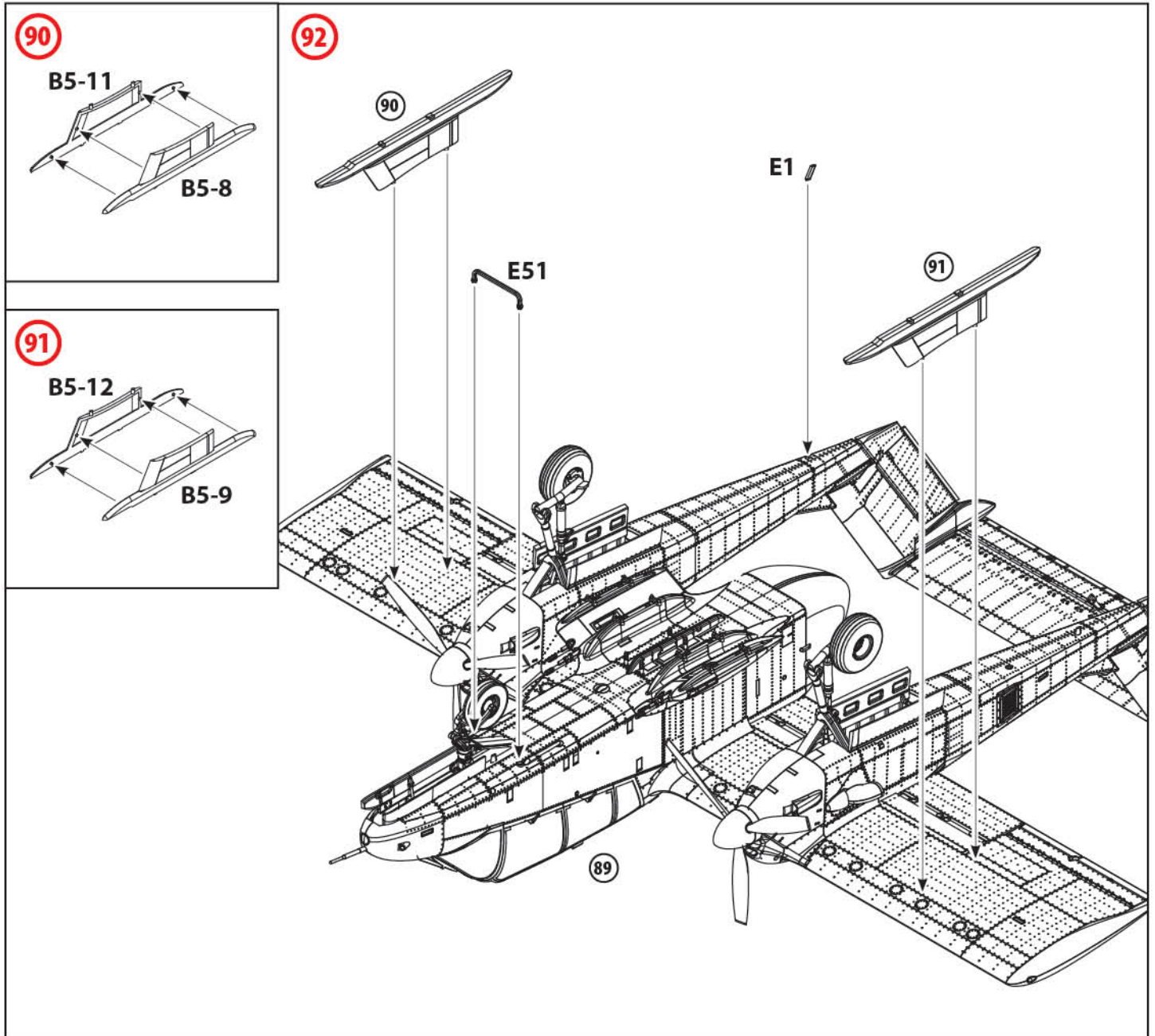

# OV-10D+ Bronco

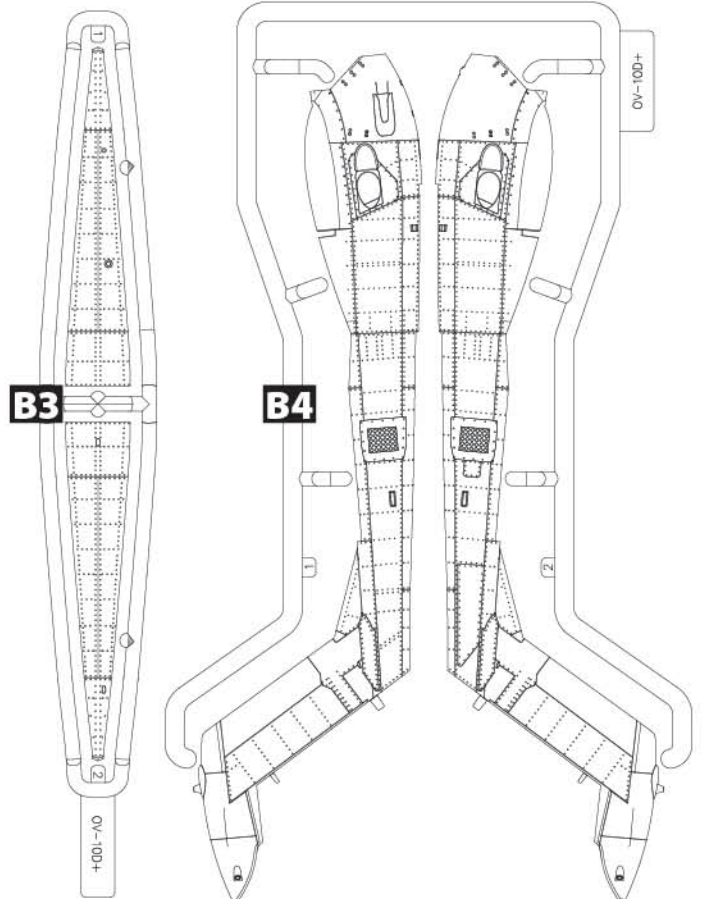
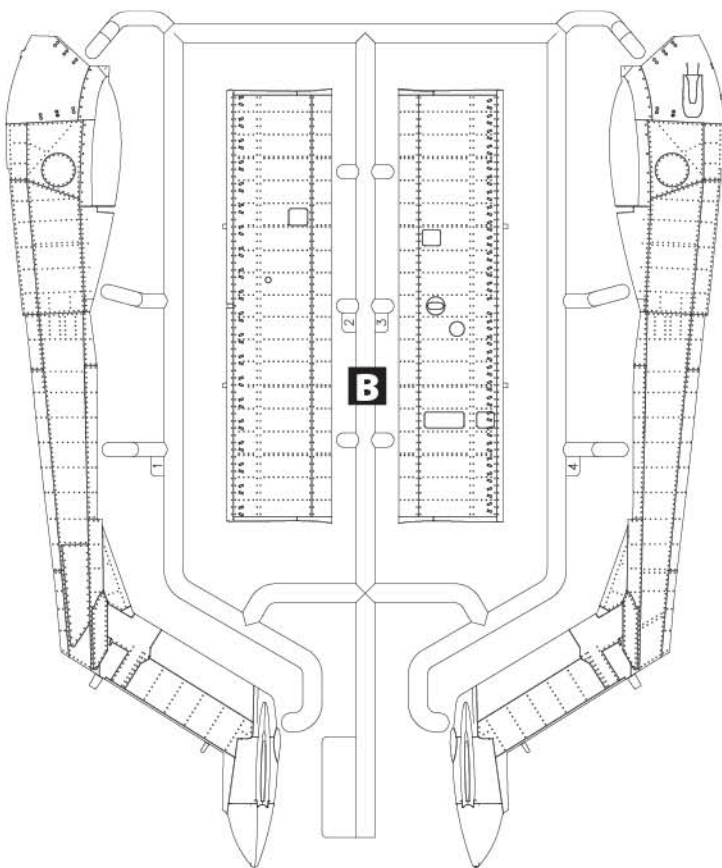
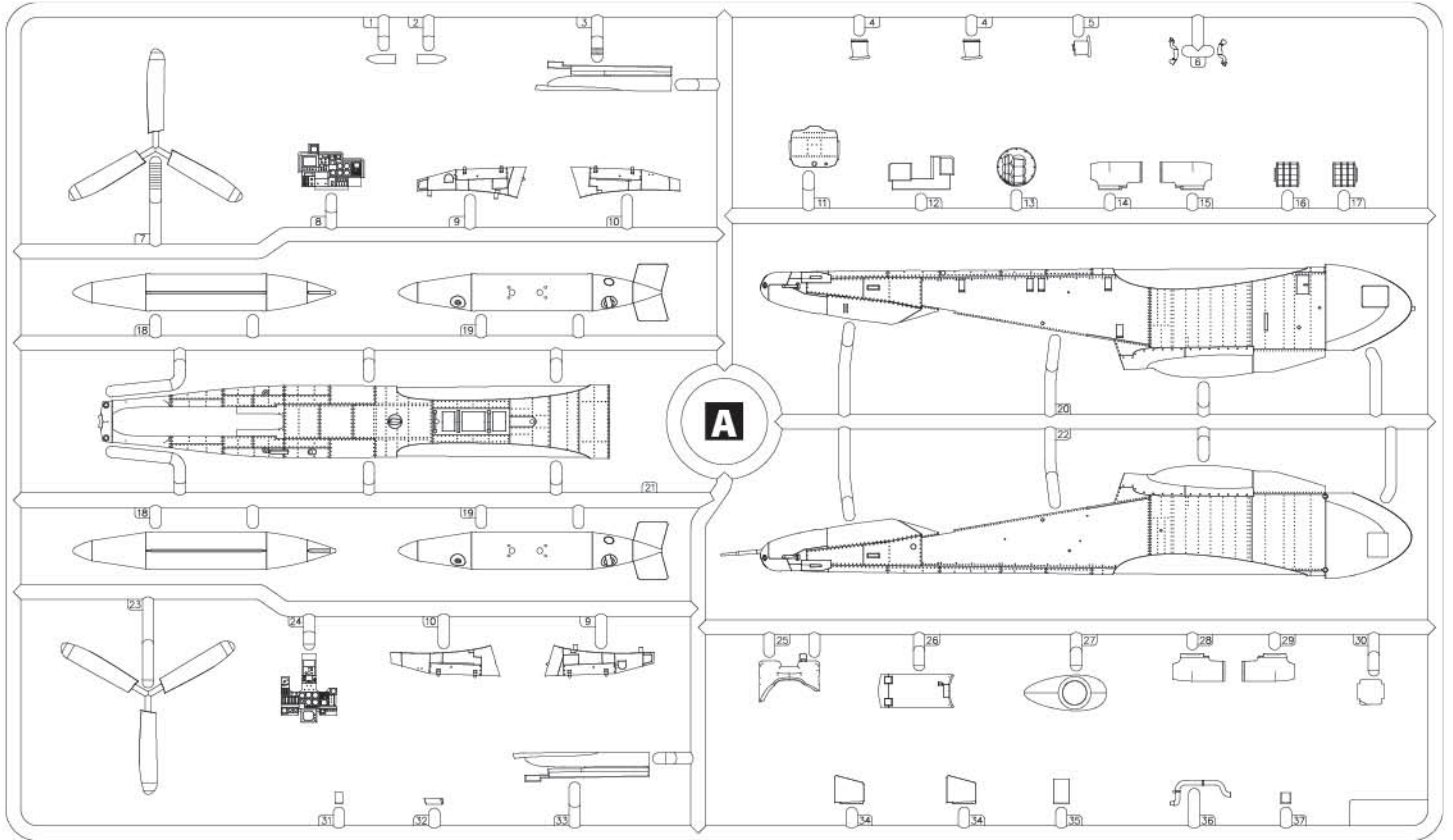

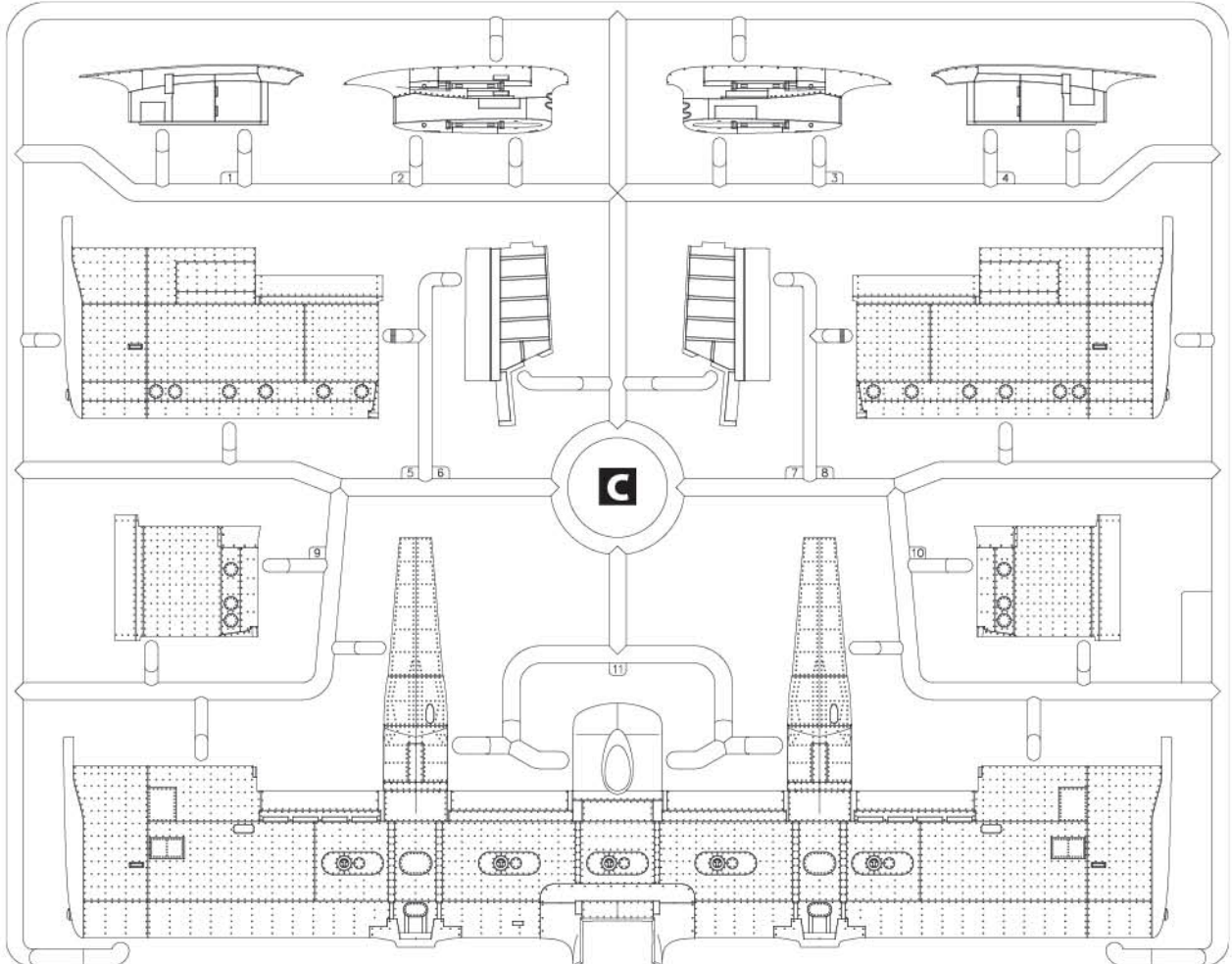
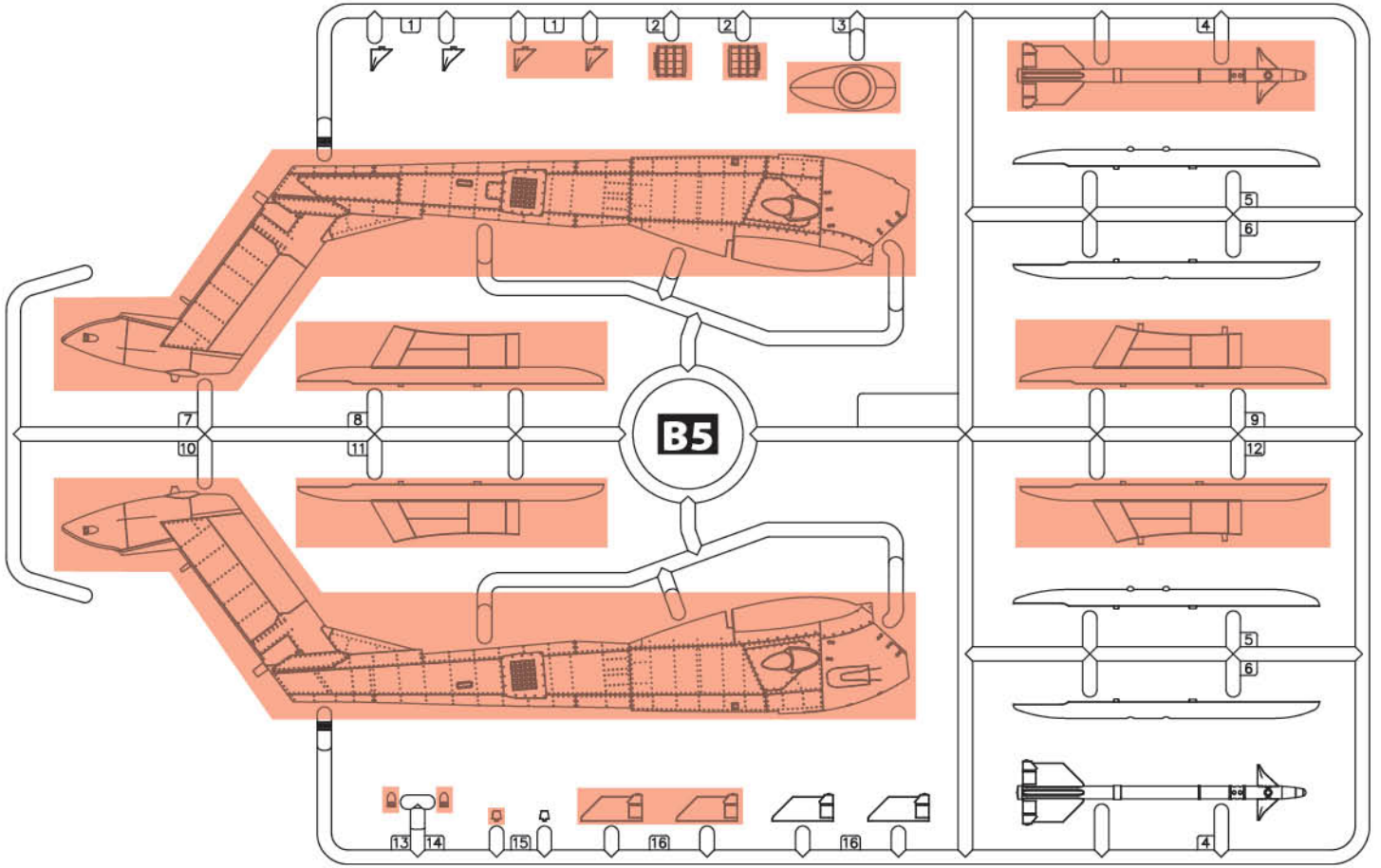

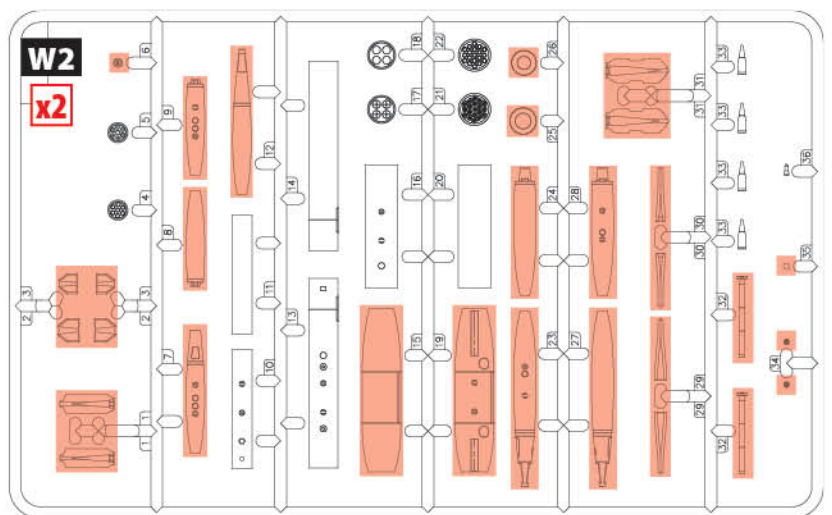
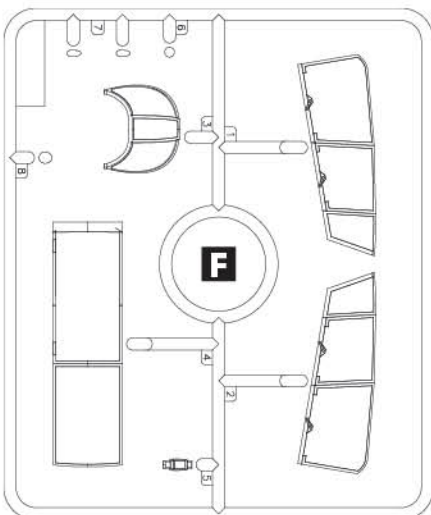
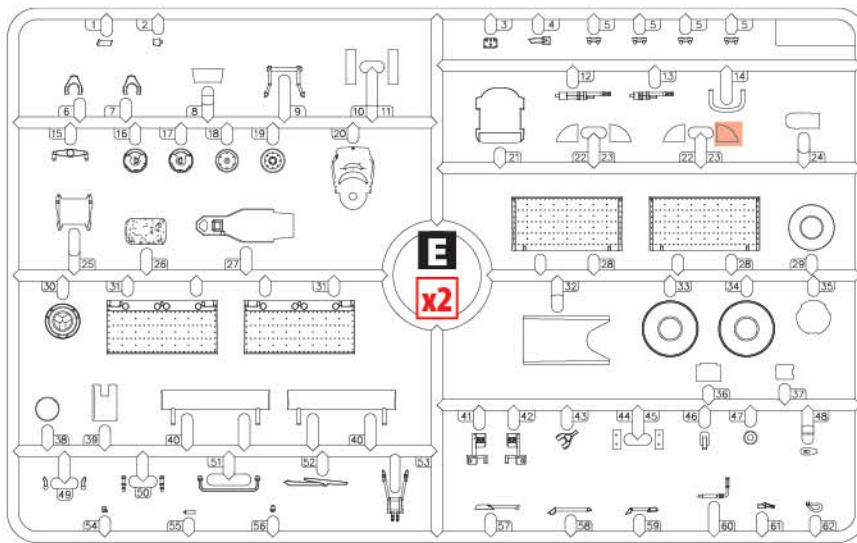
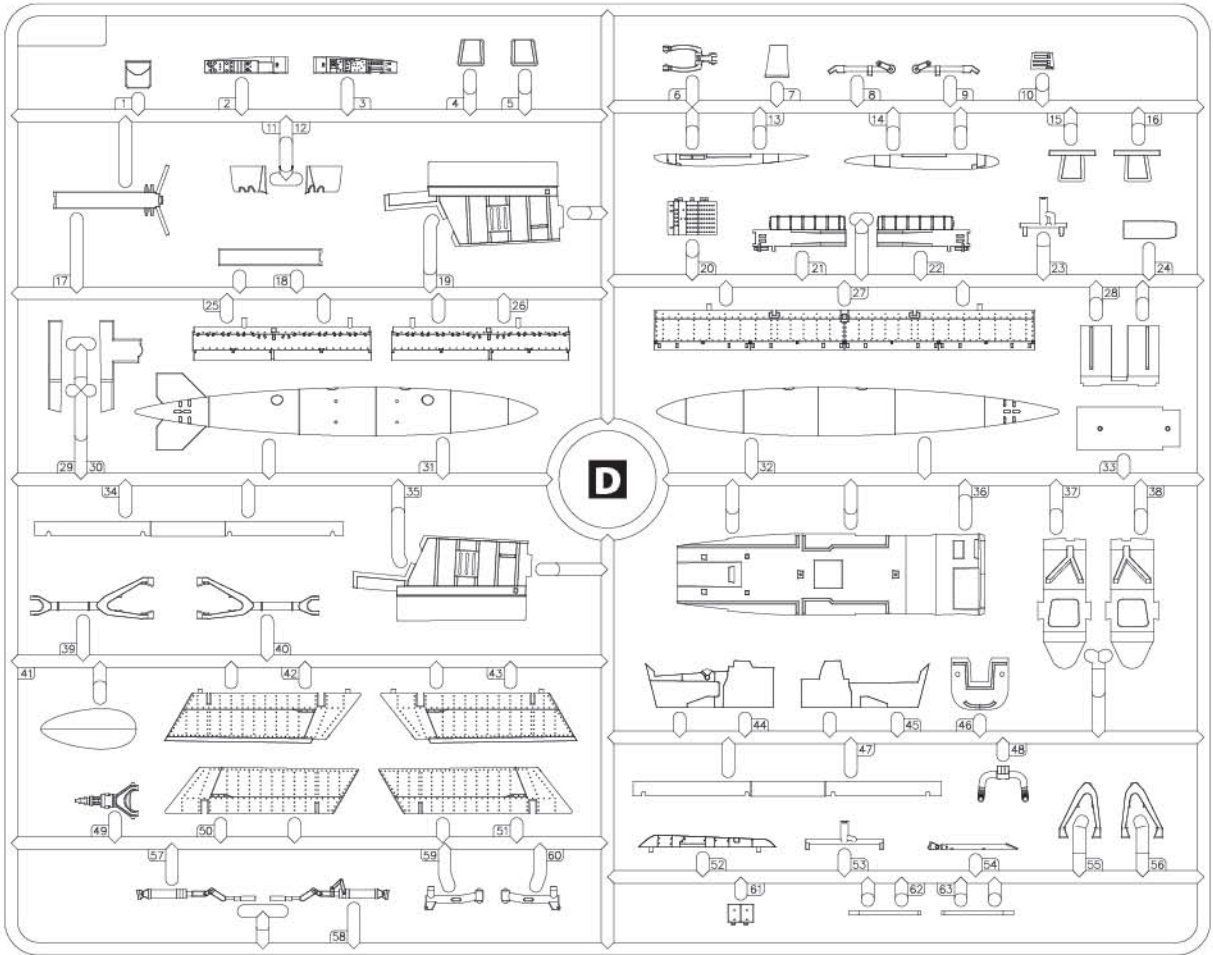



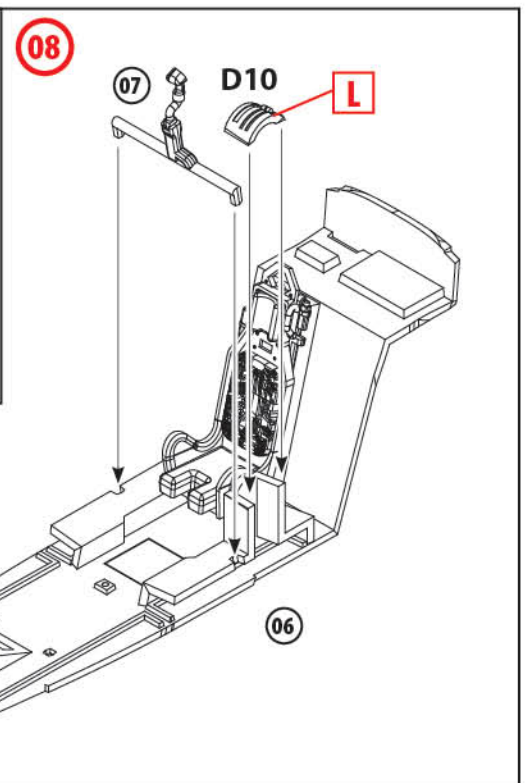
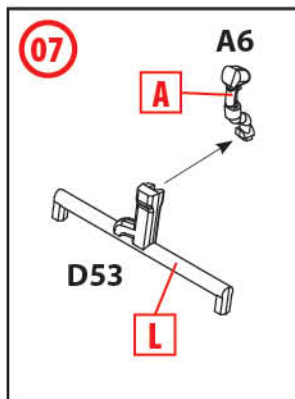
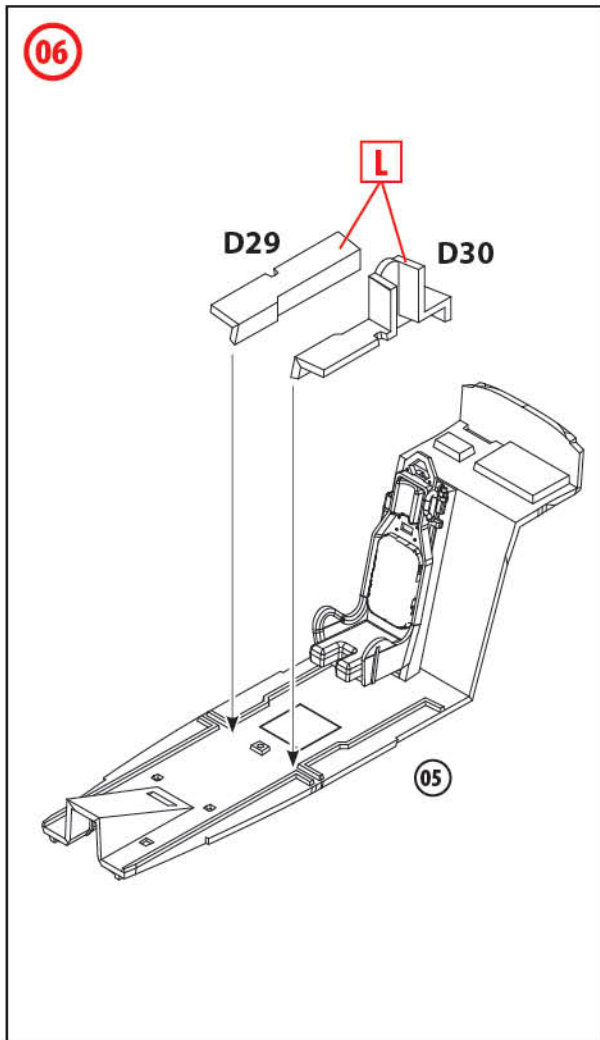
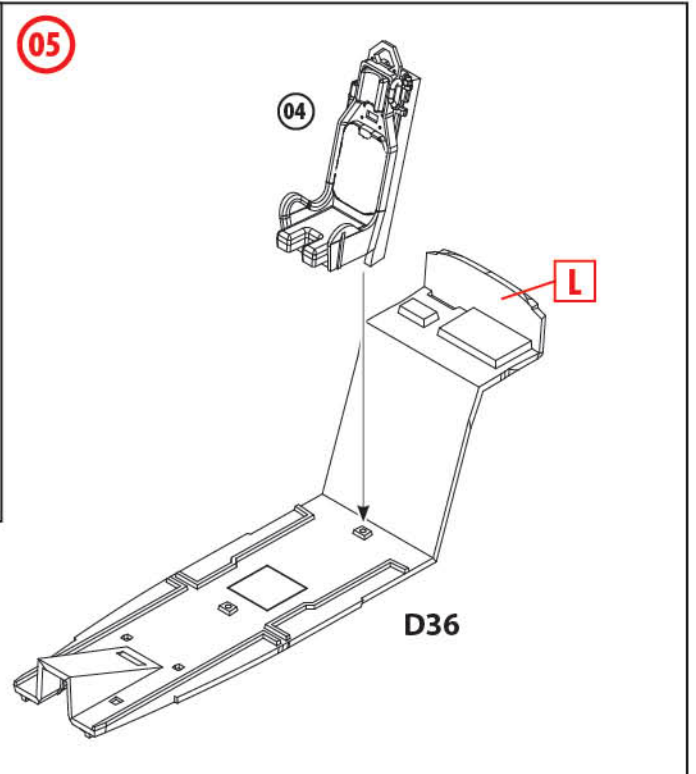
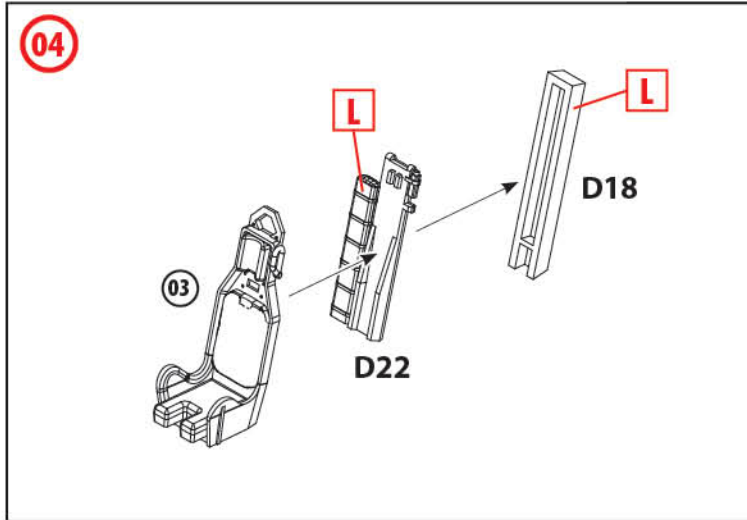
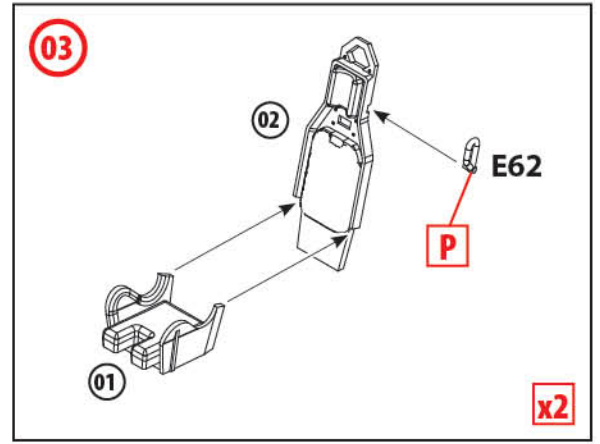
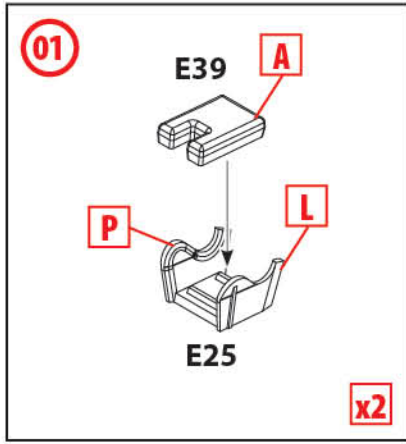

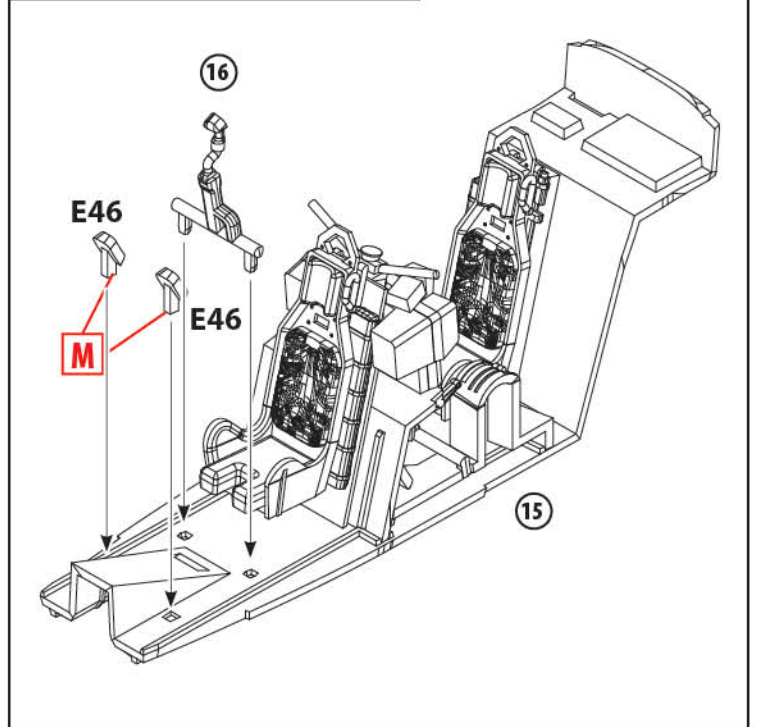
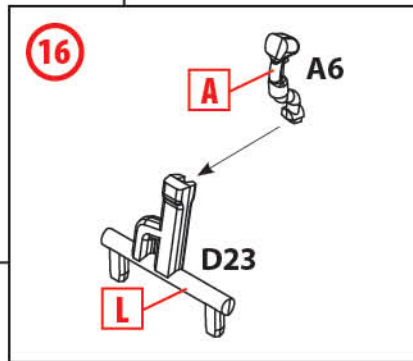
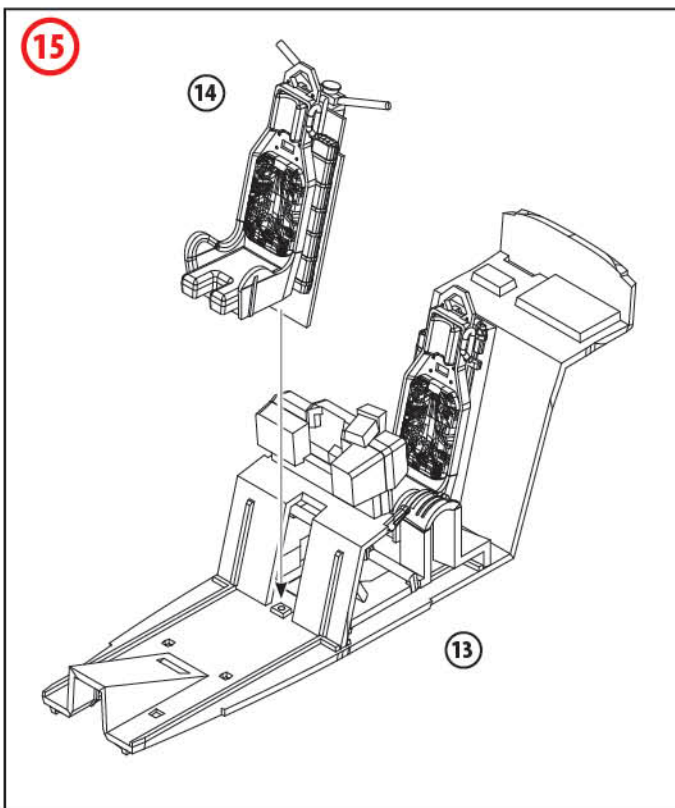
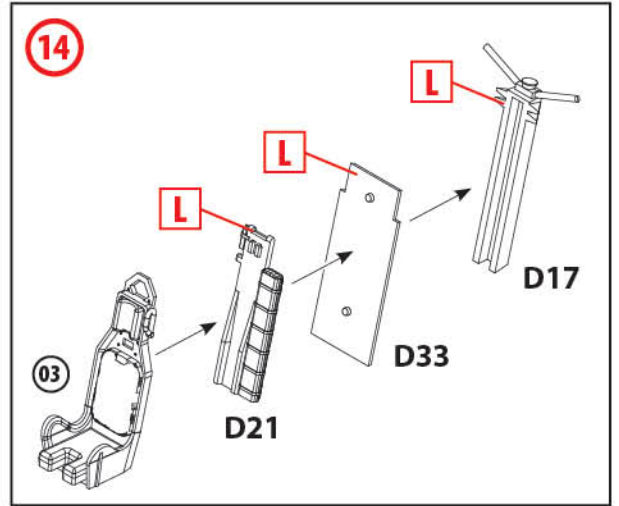
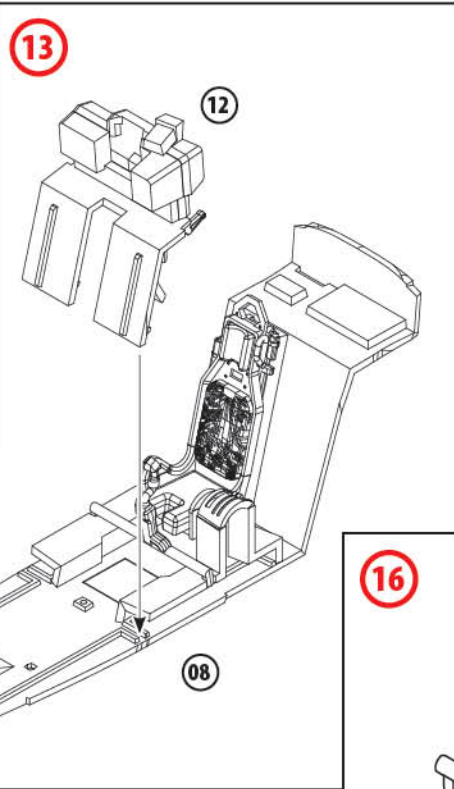
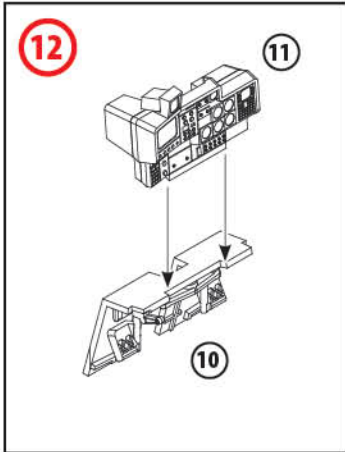
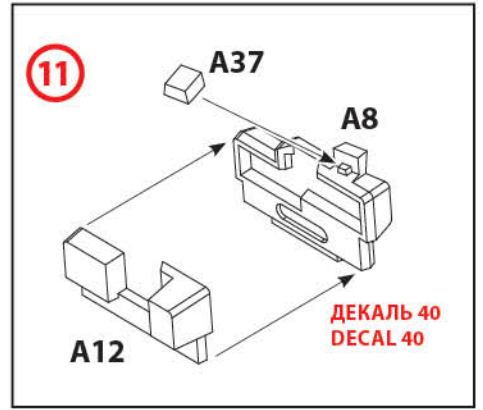
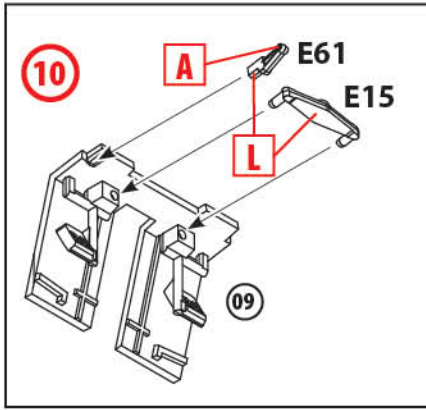
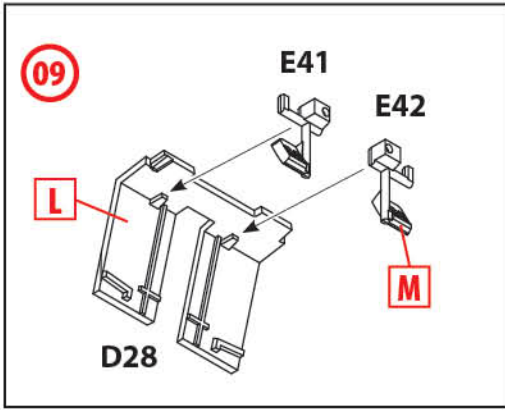

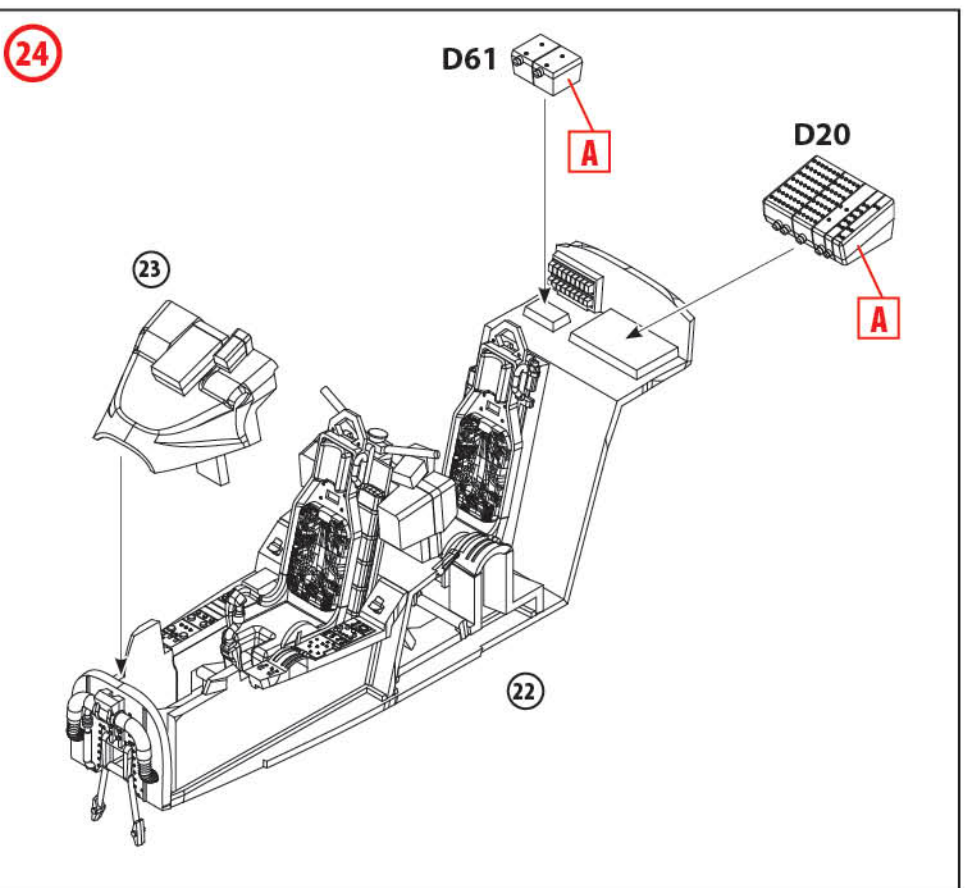
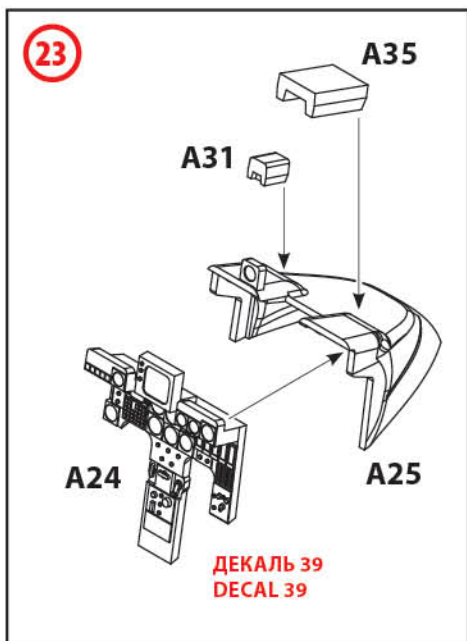
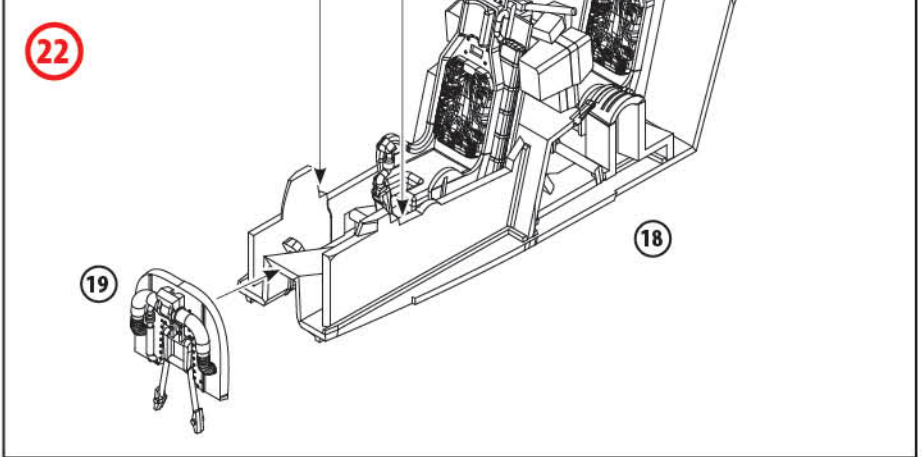
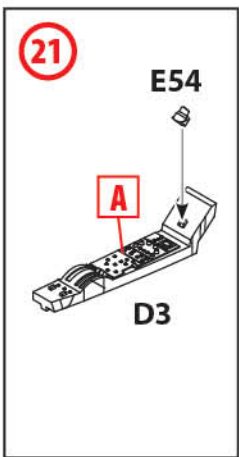
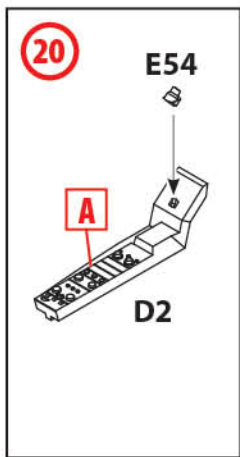
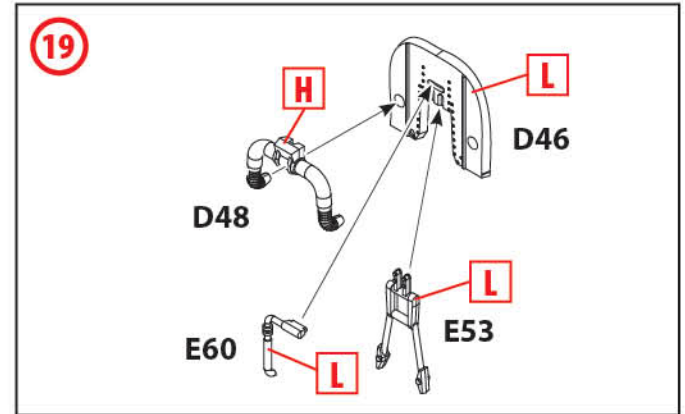
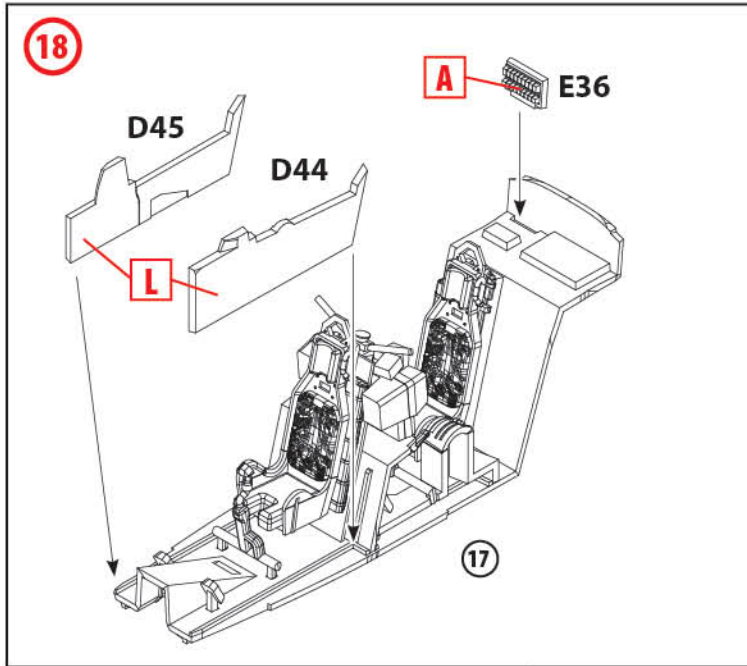

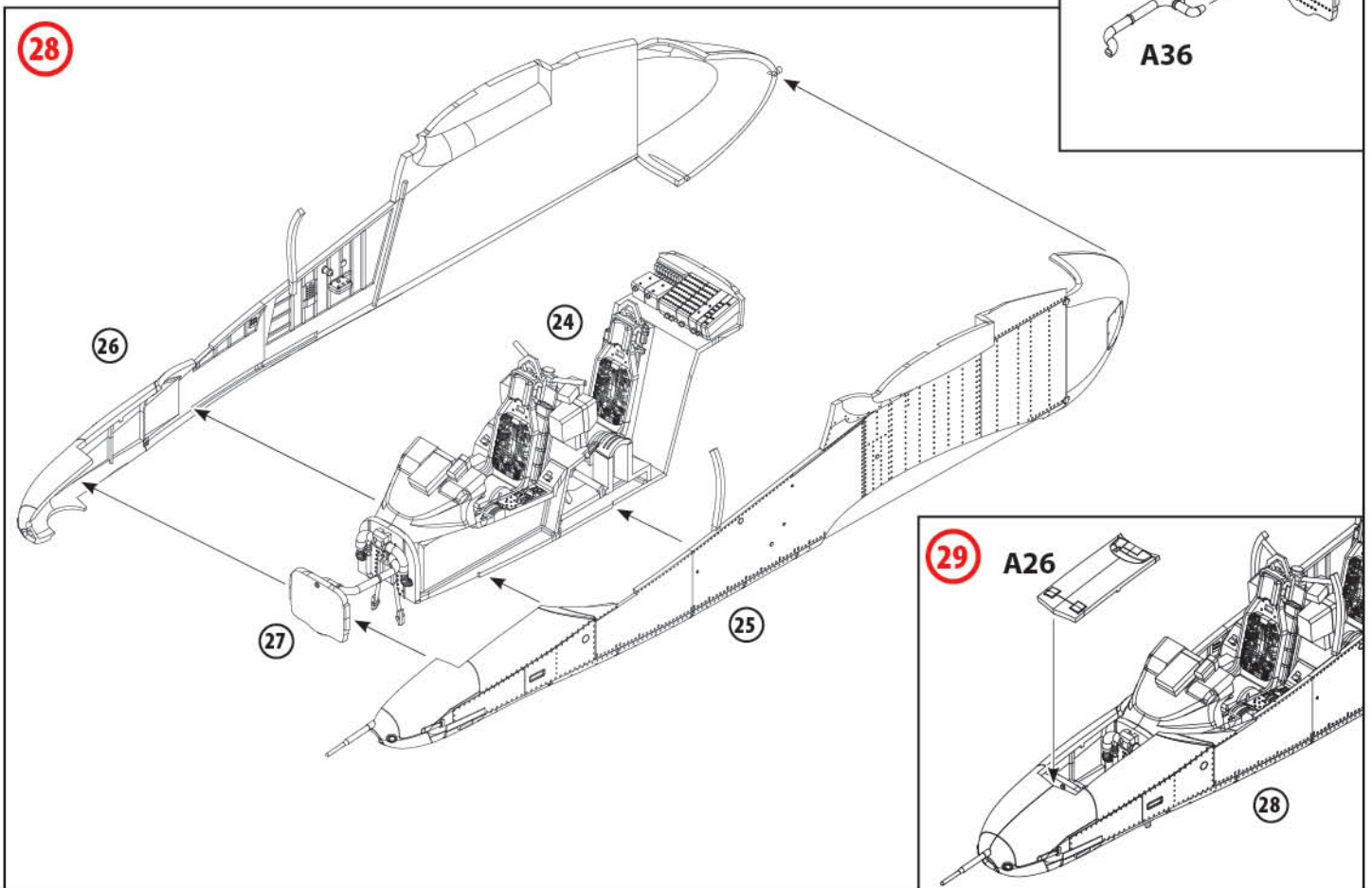
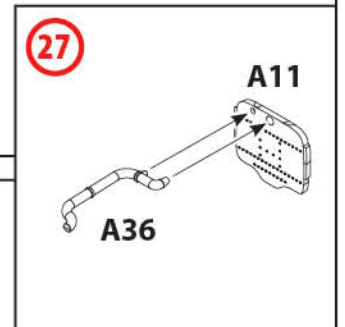
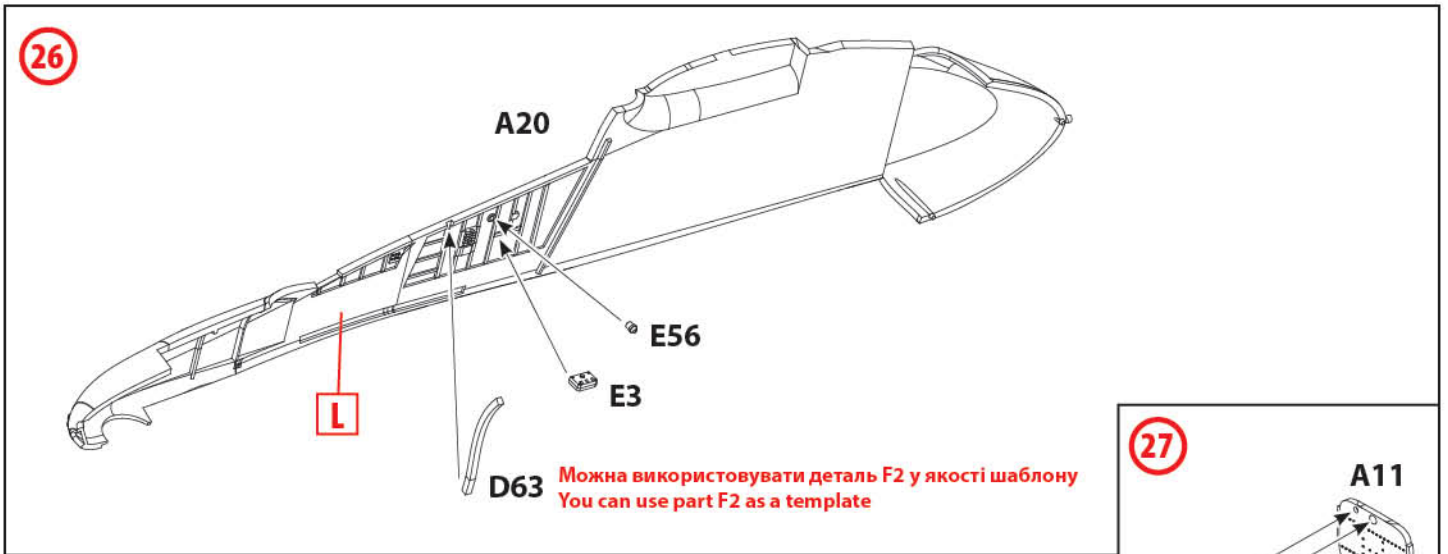
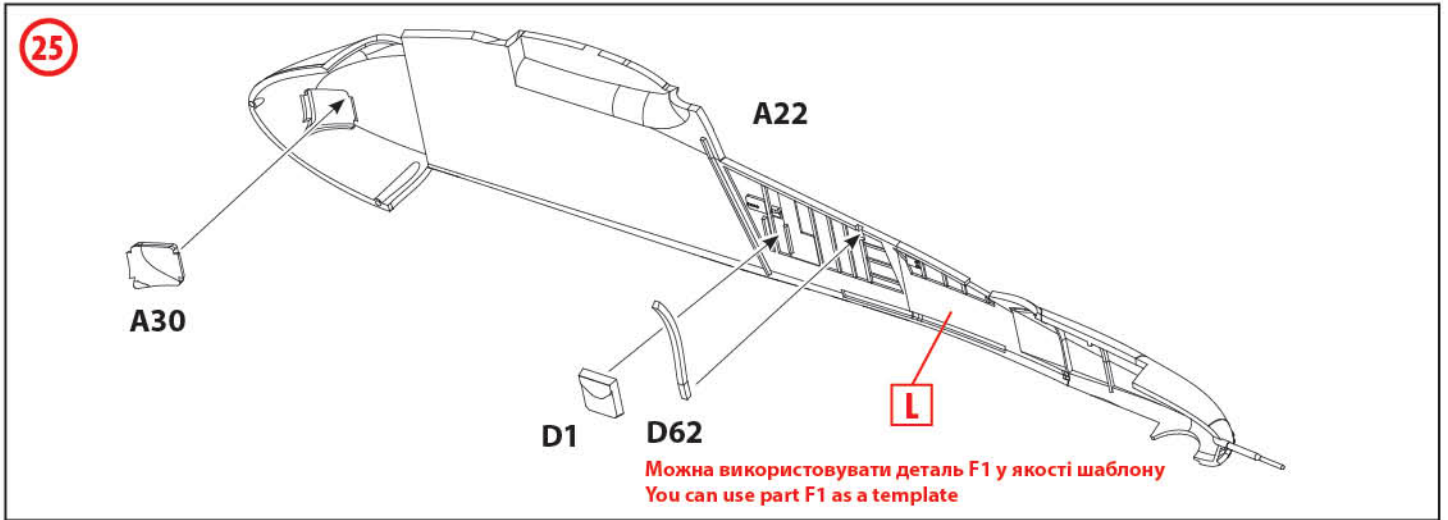

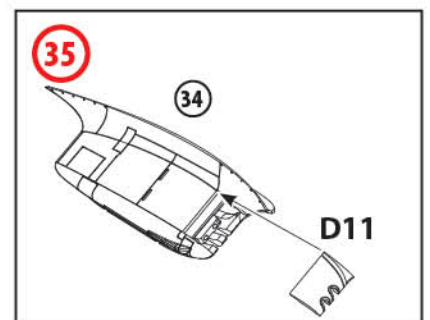
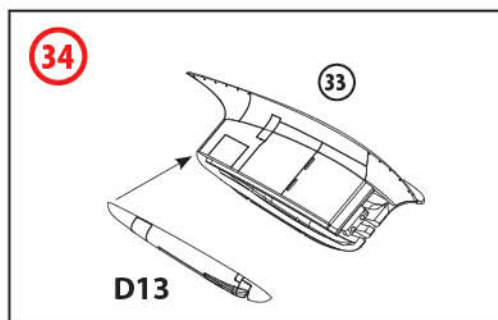
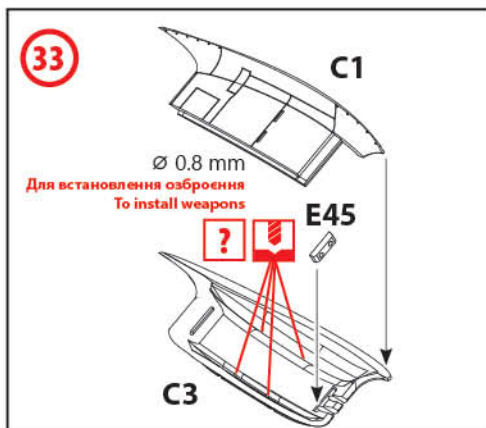
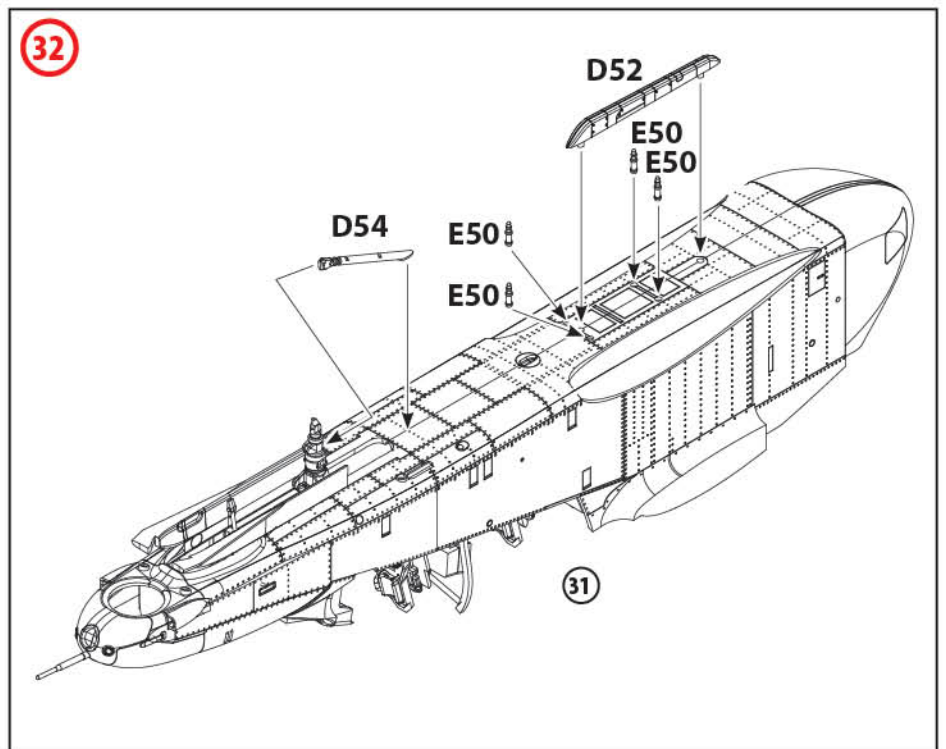
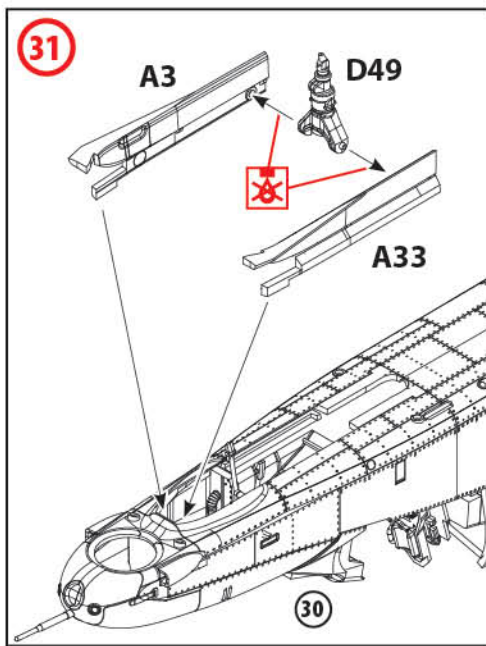
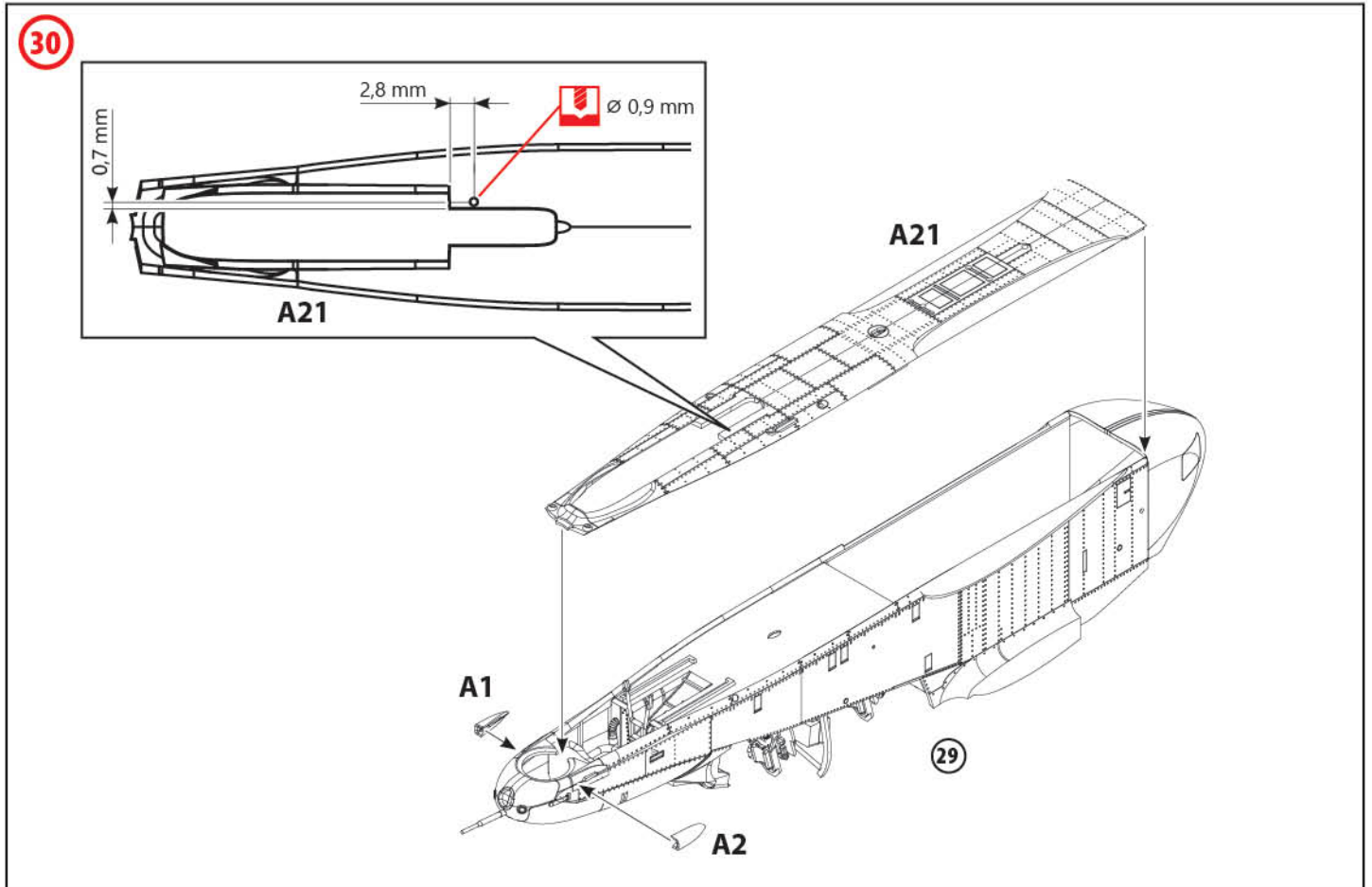

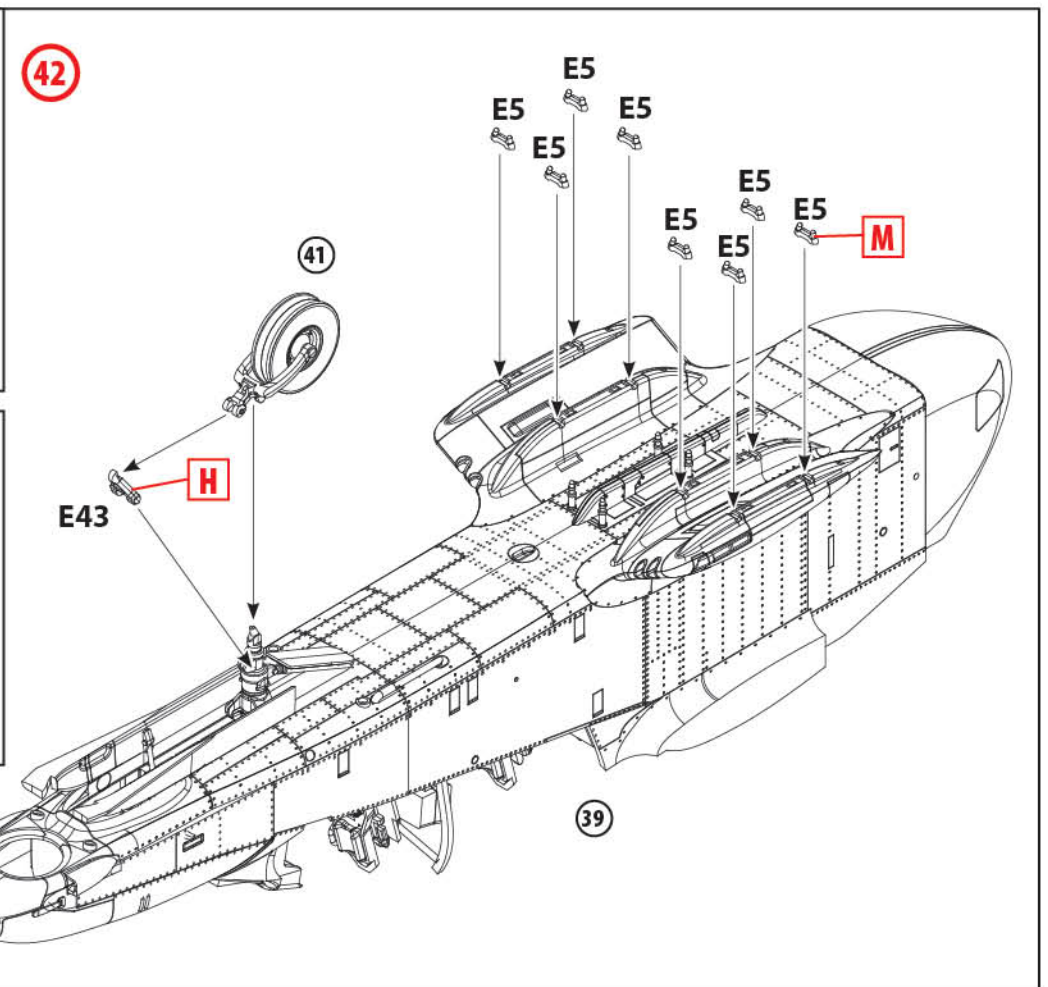
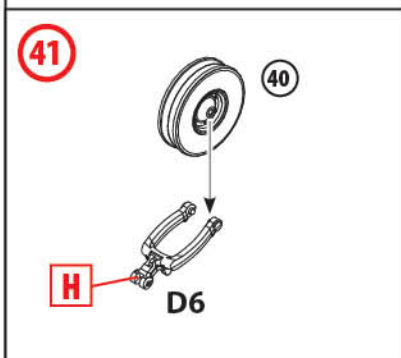
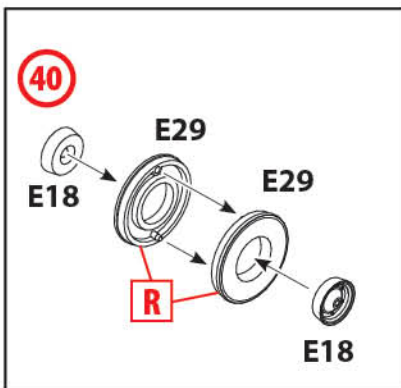
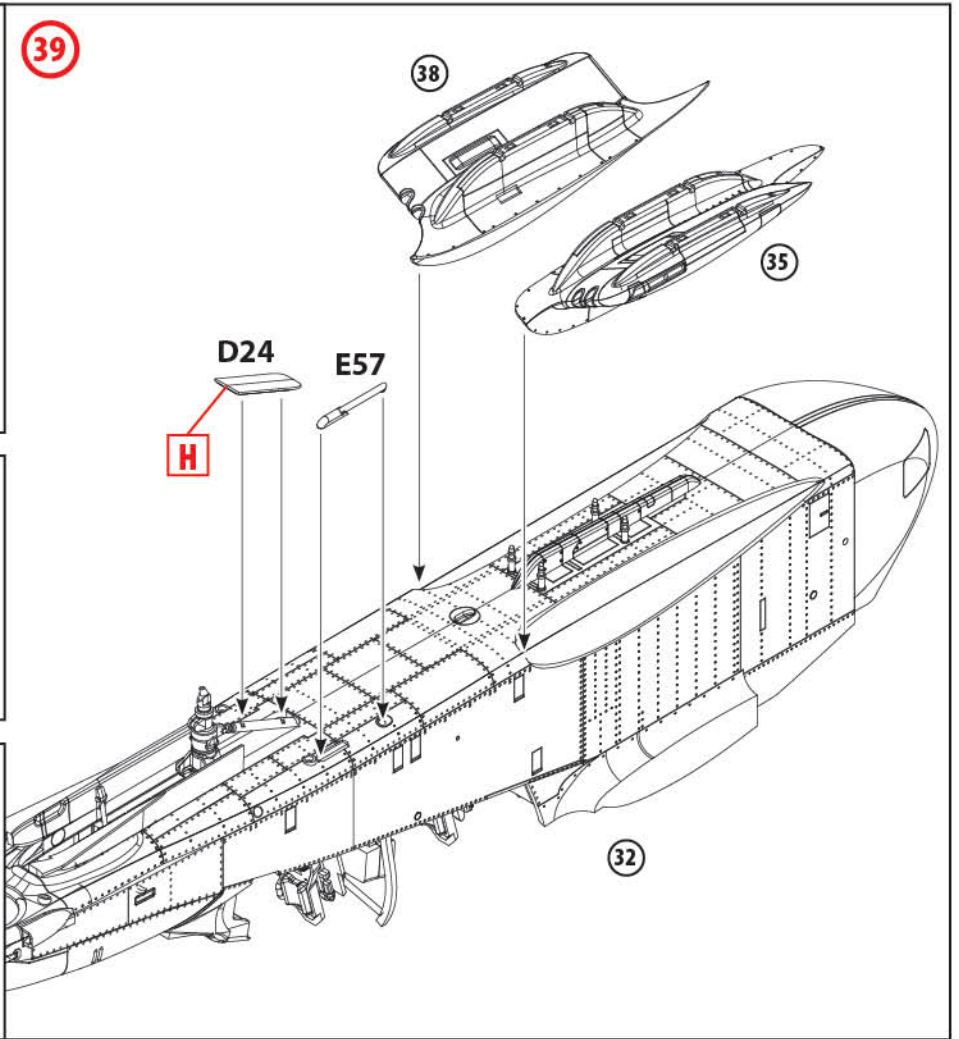
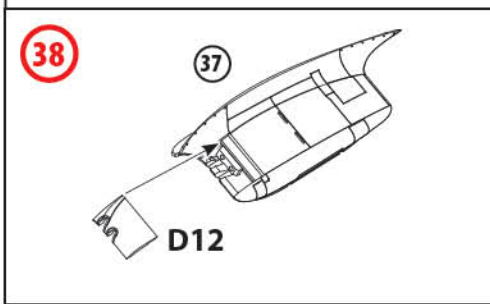
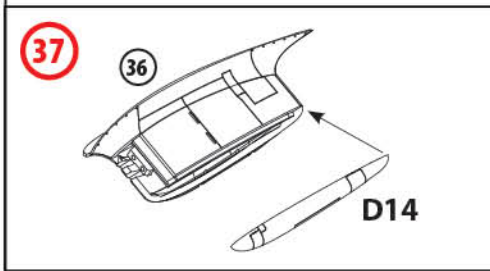
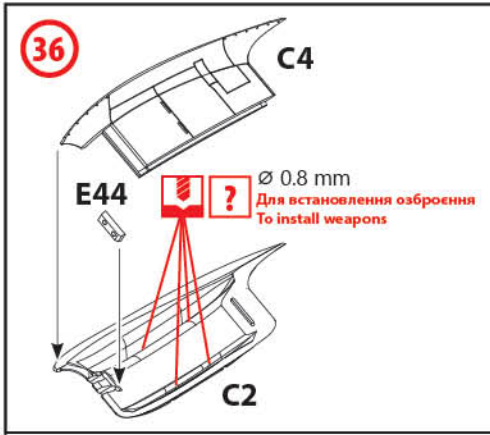

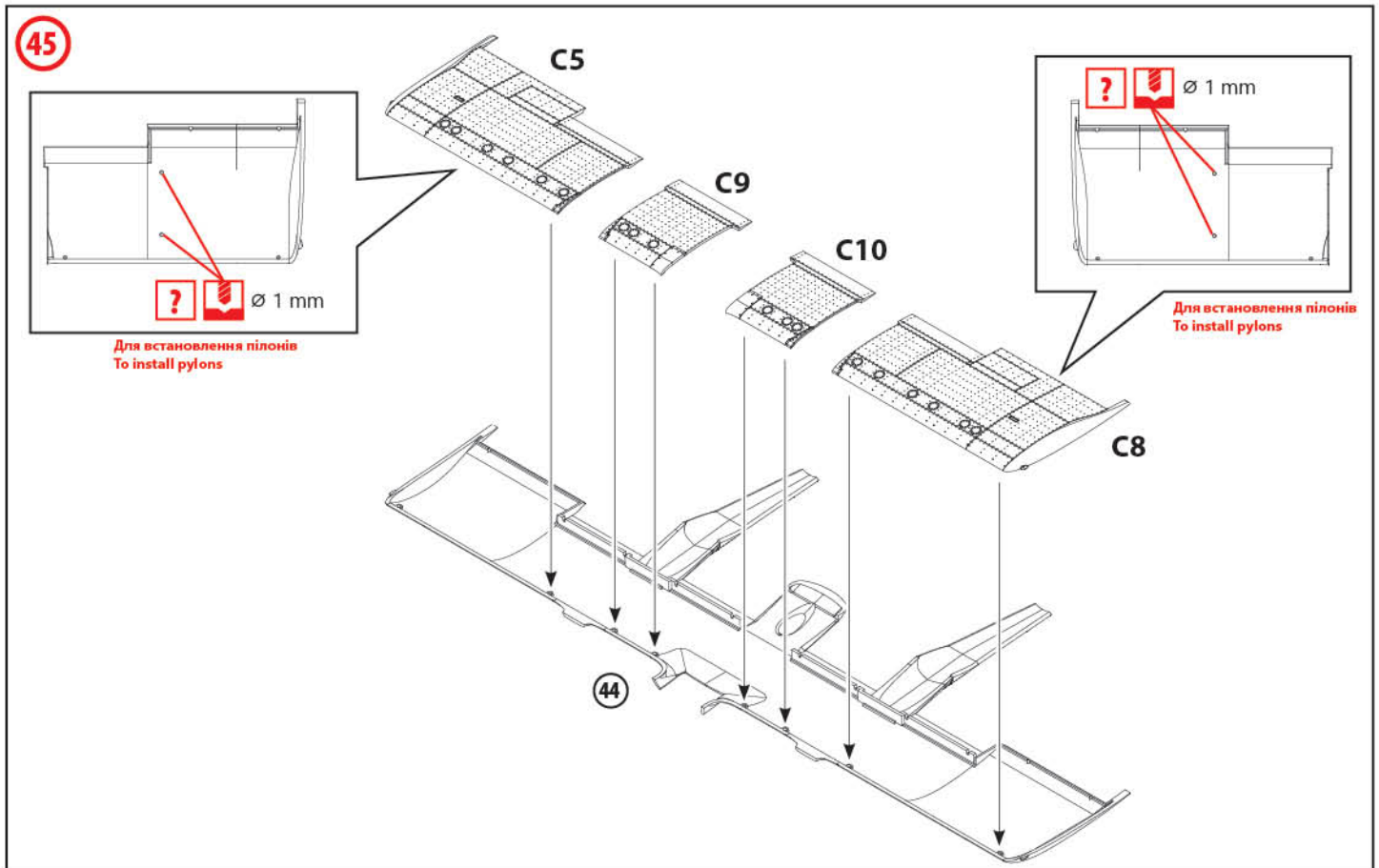
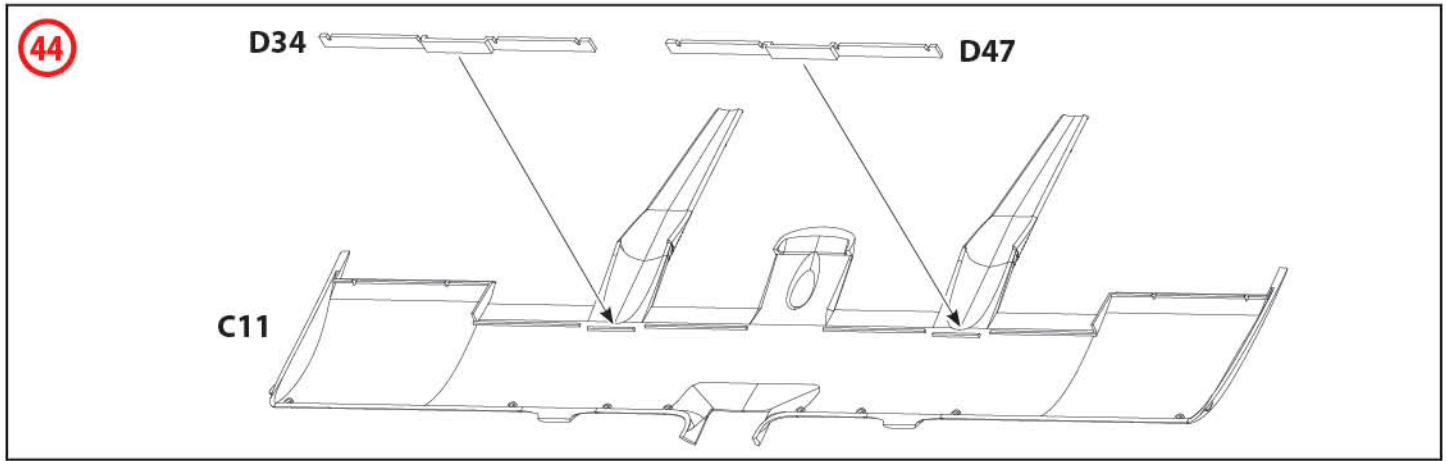
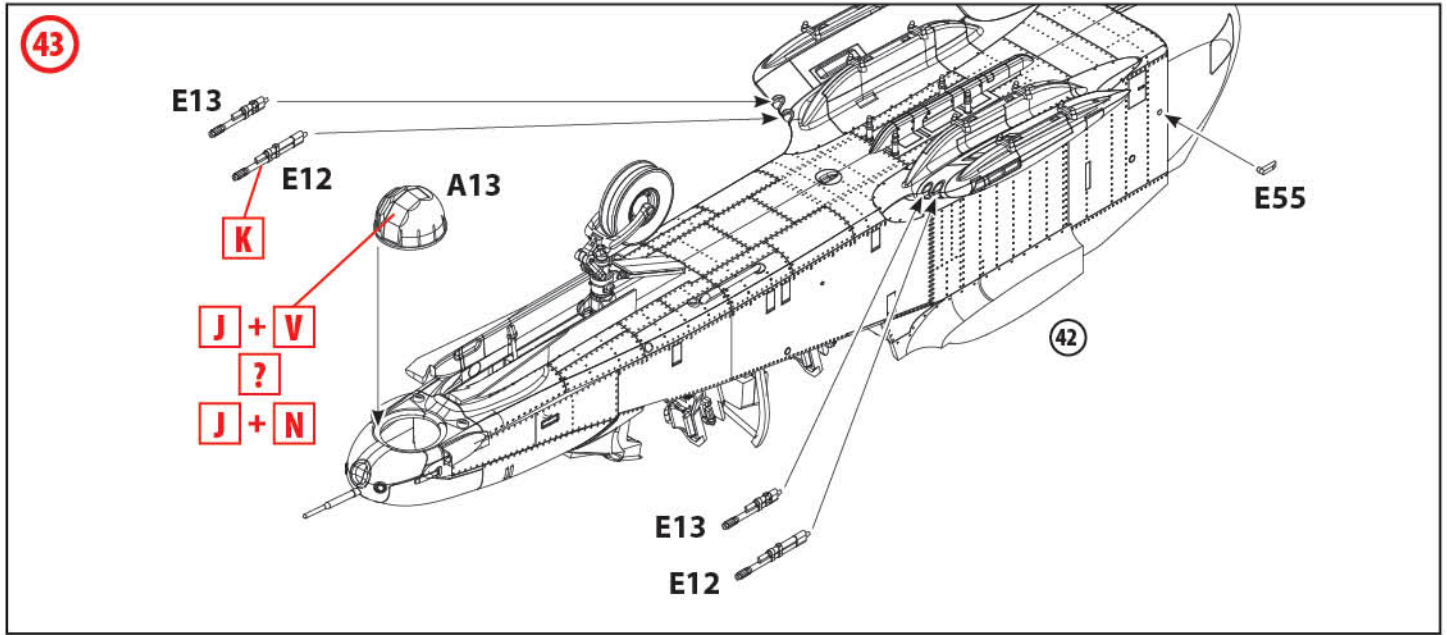

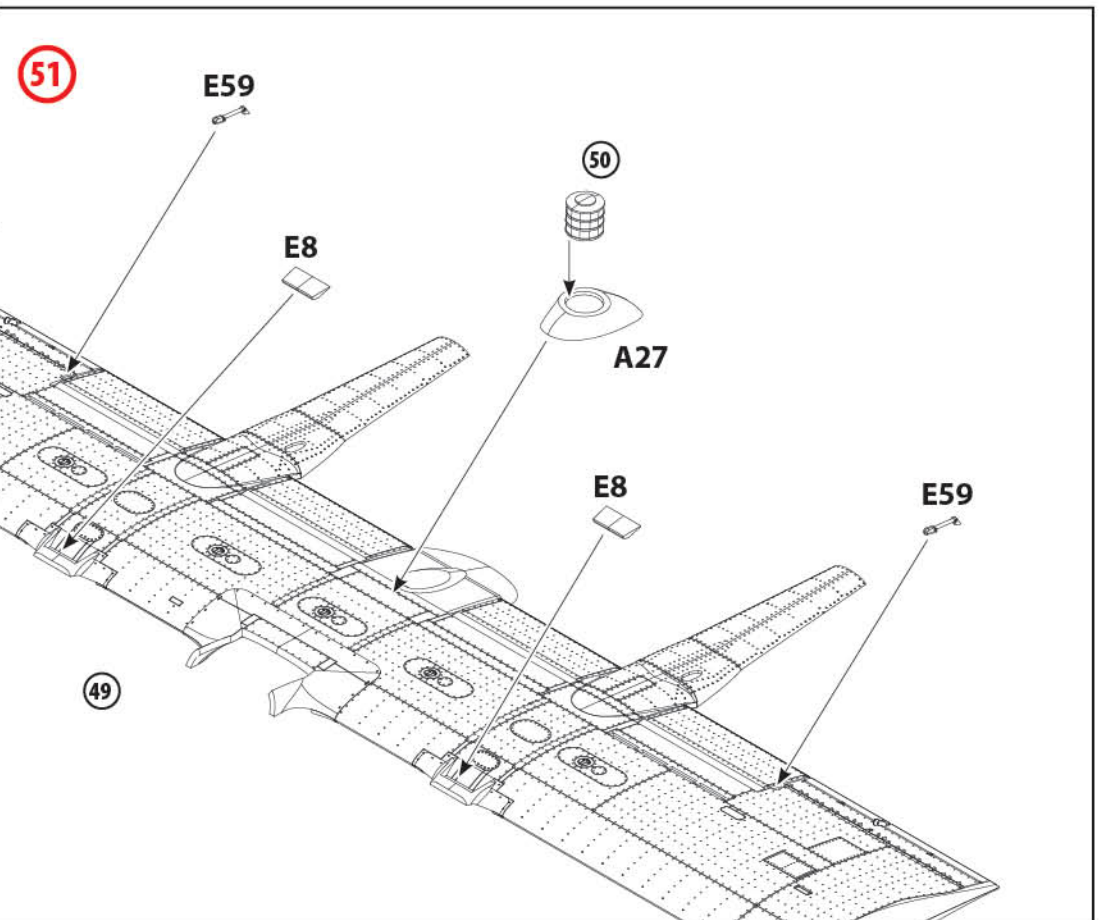
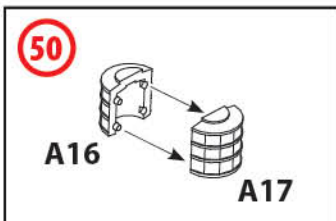
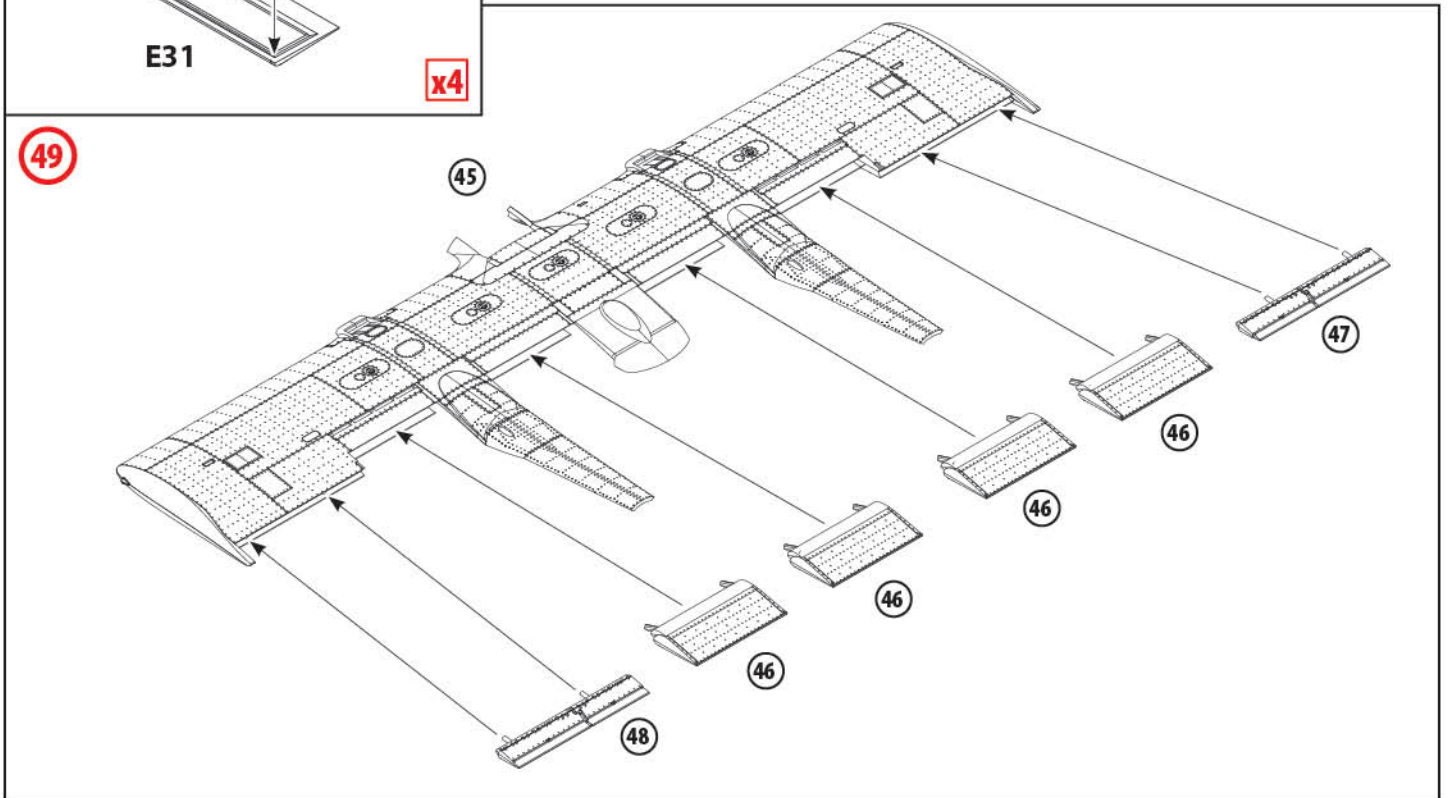
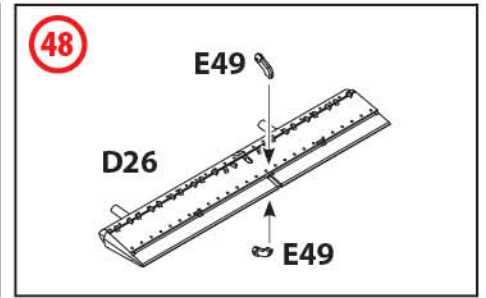
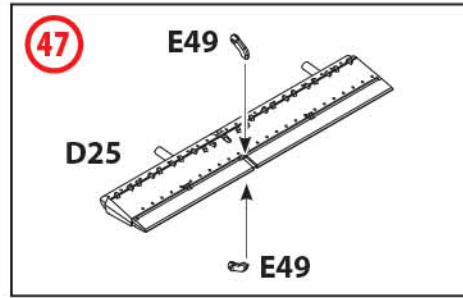
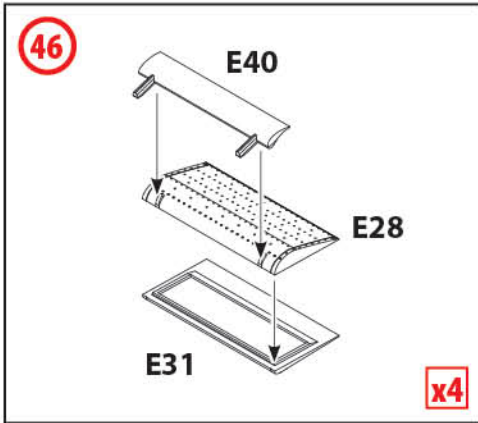



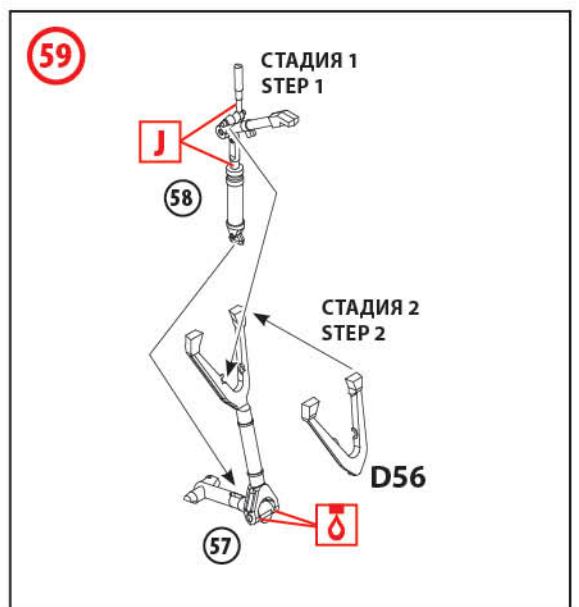
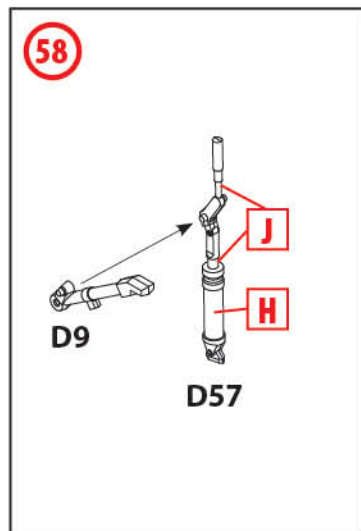
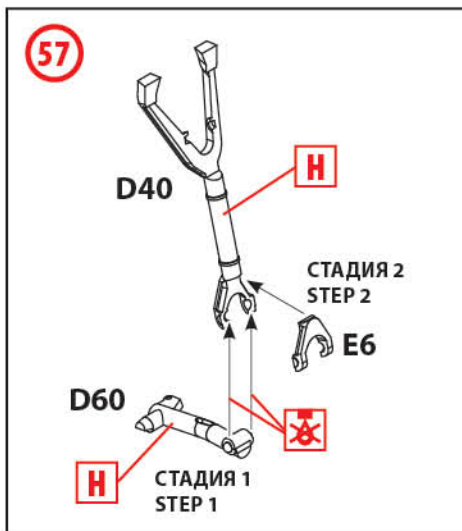
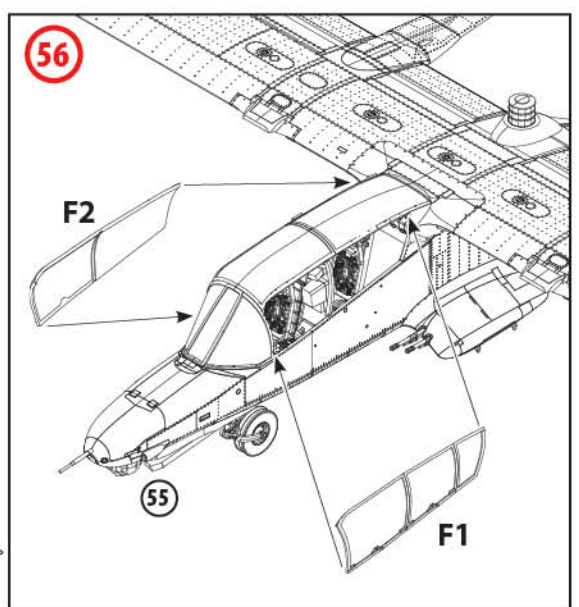
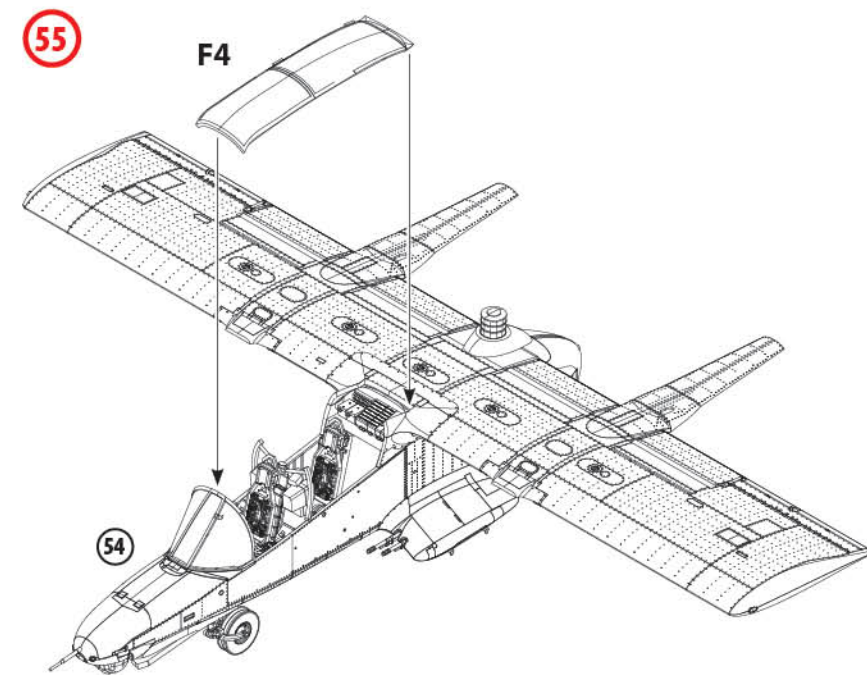
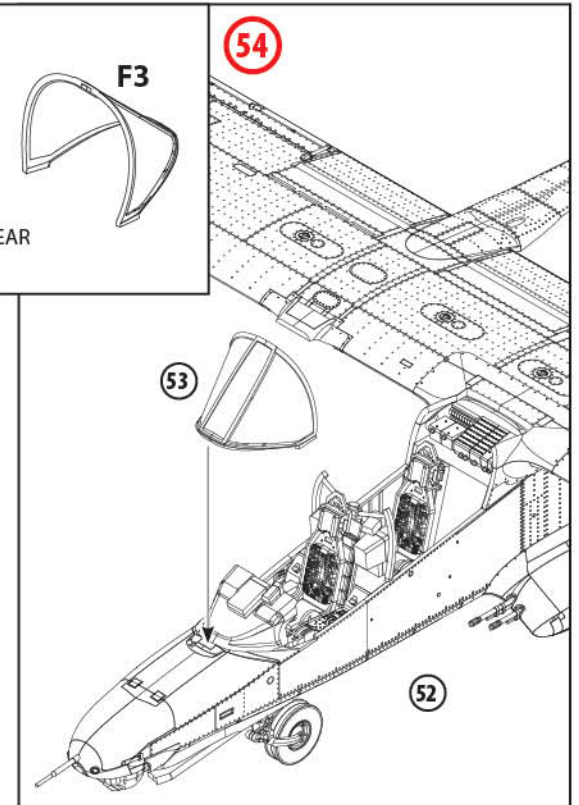
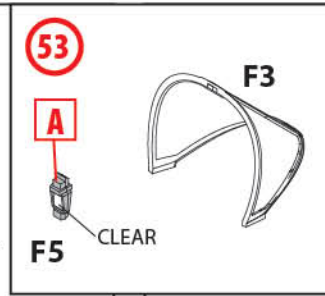
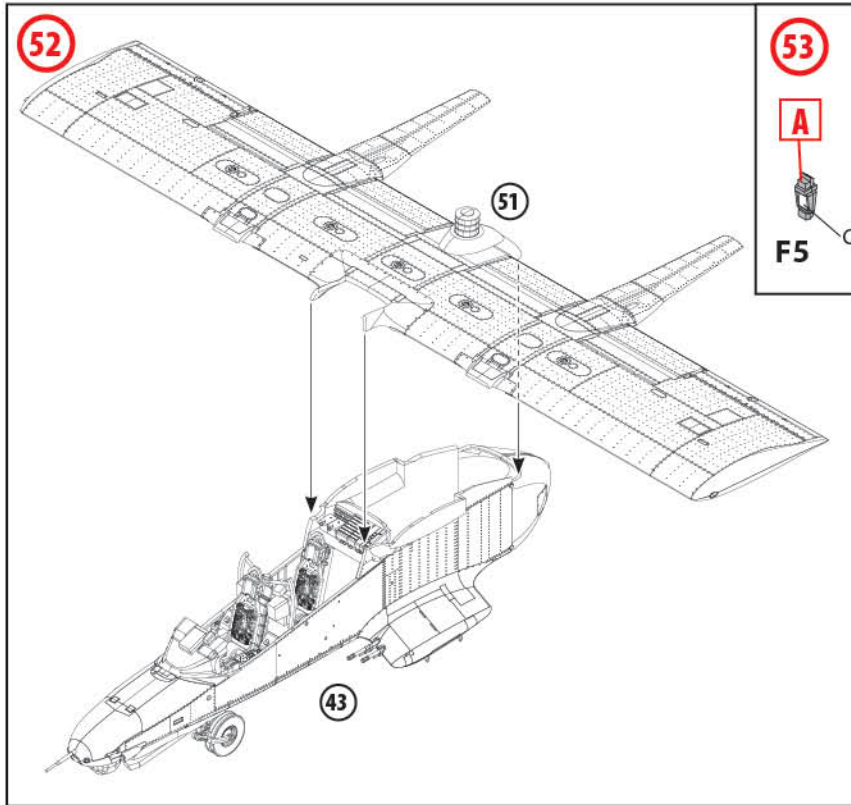

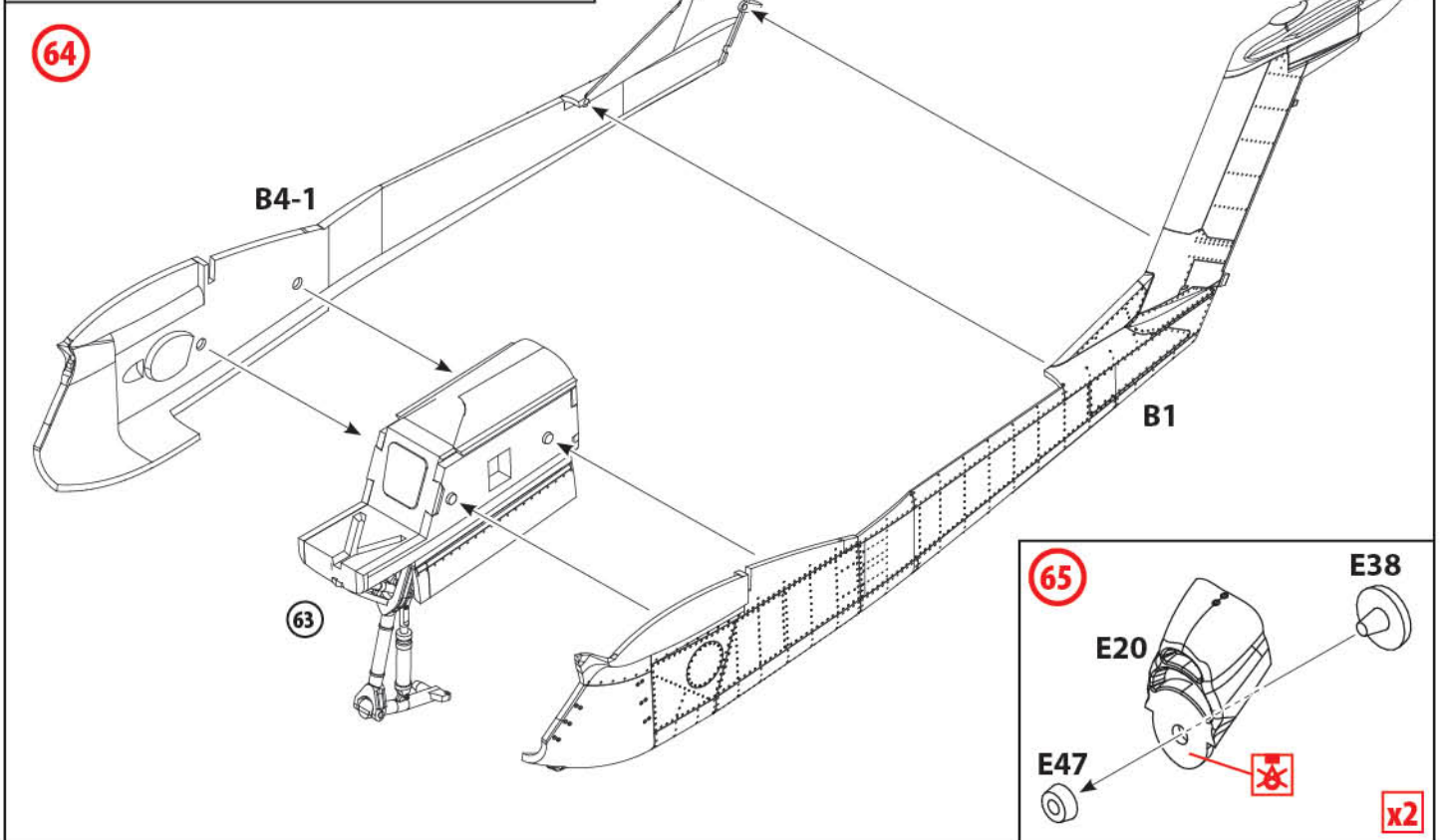
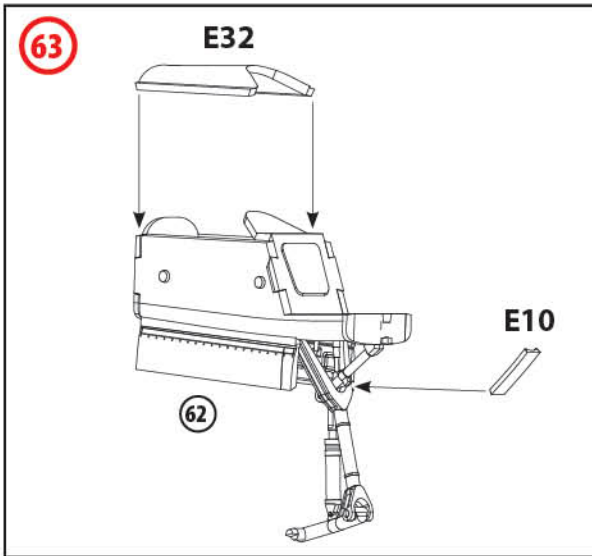
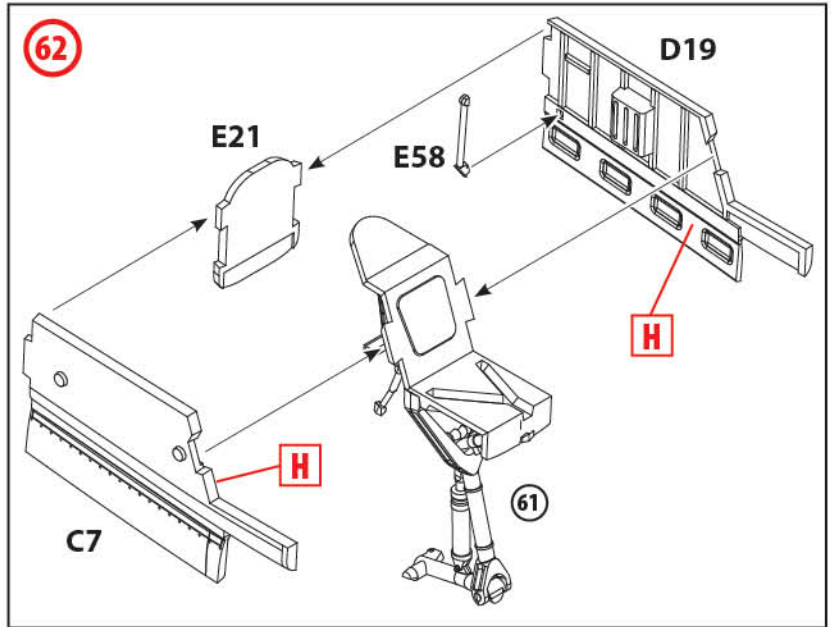
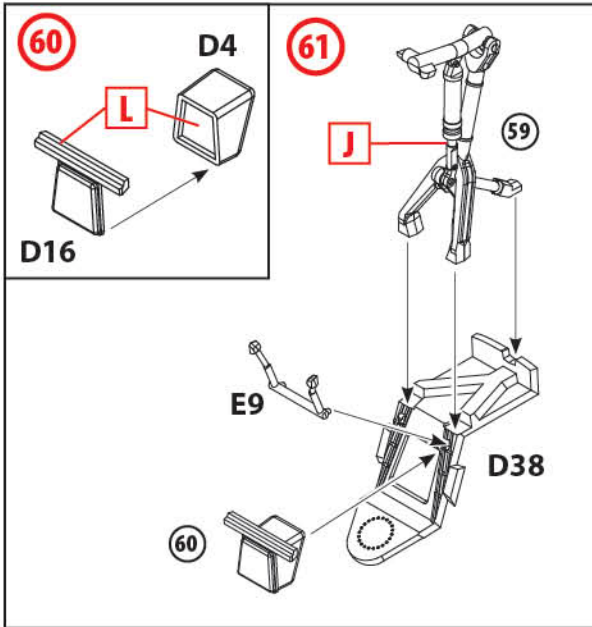

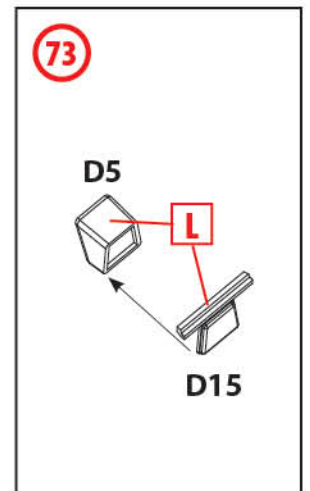
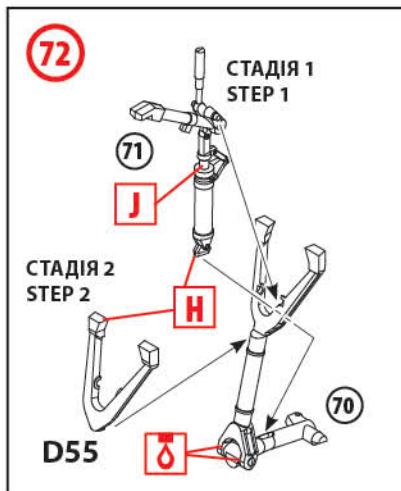
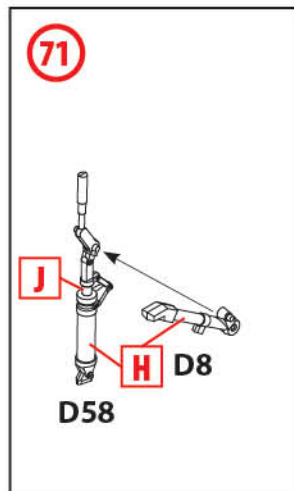
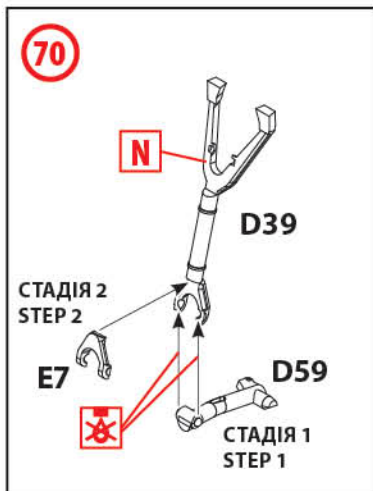
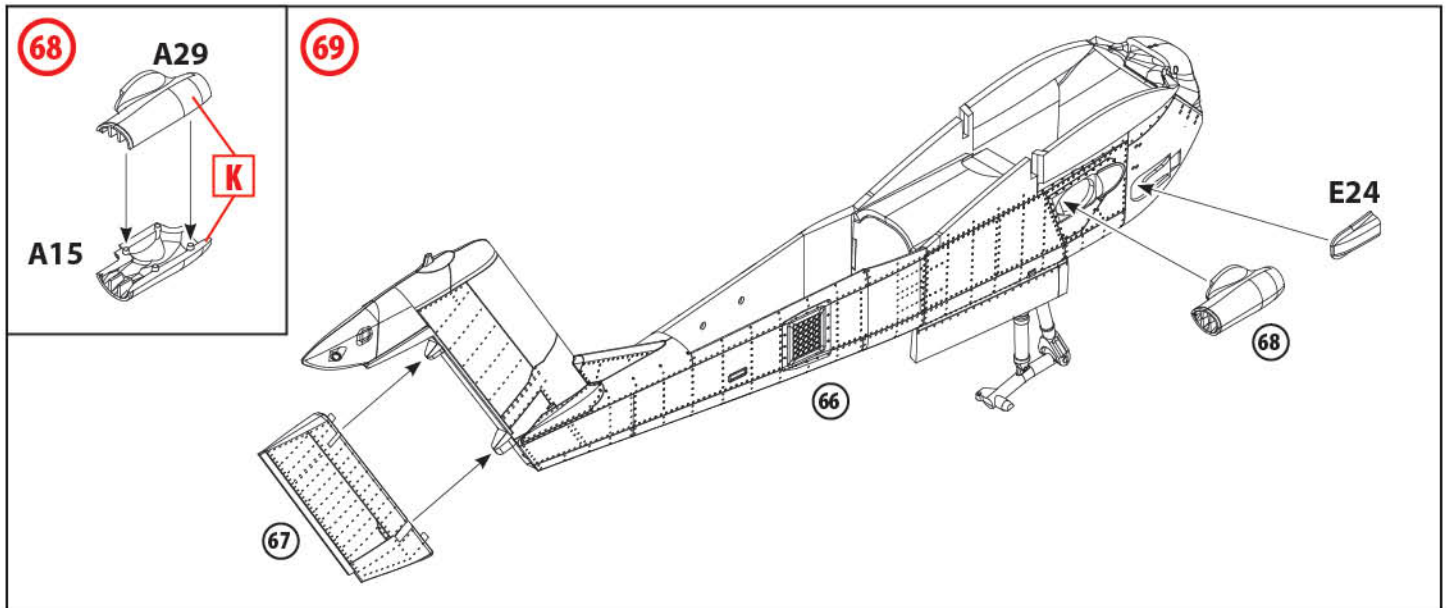
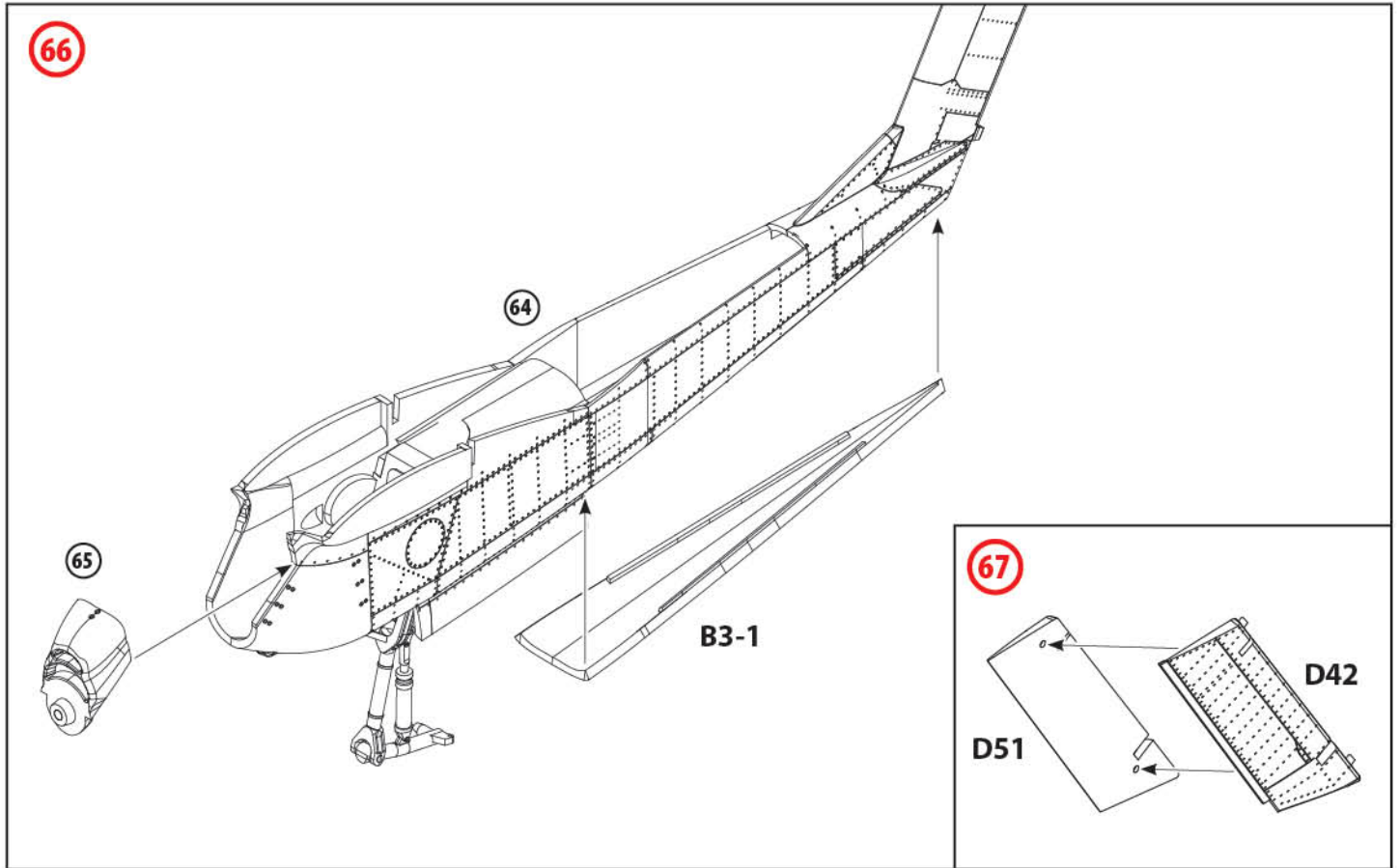

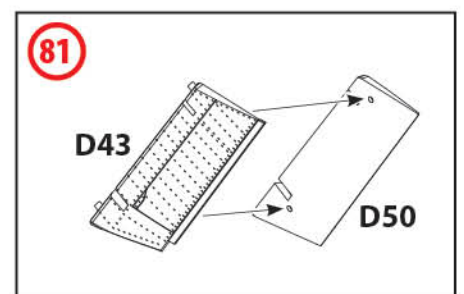
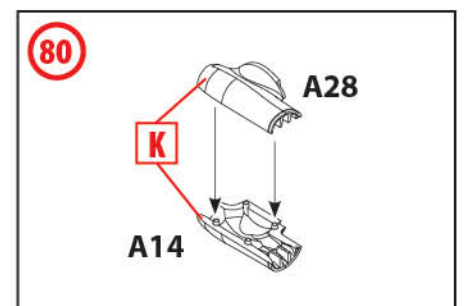
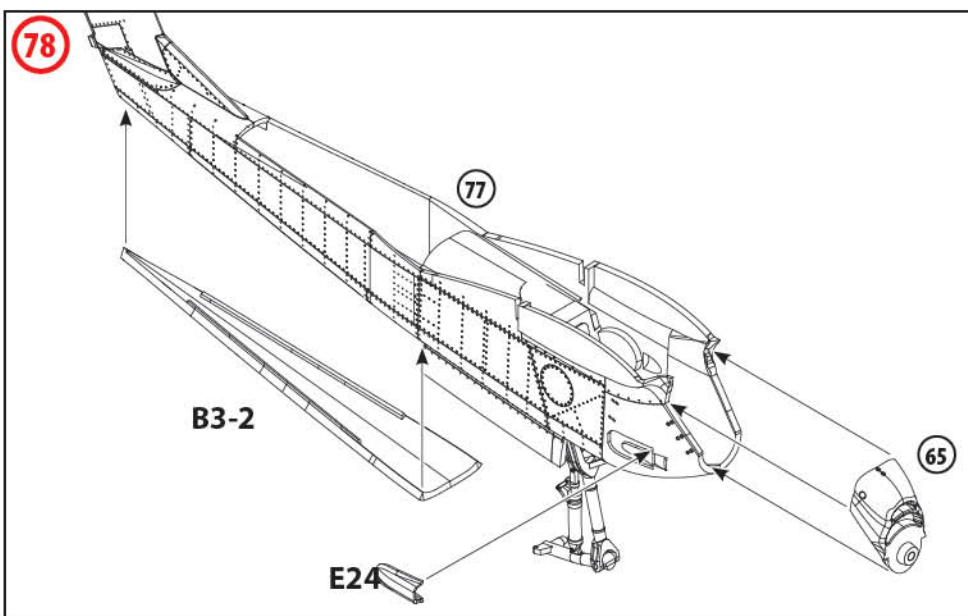
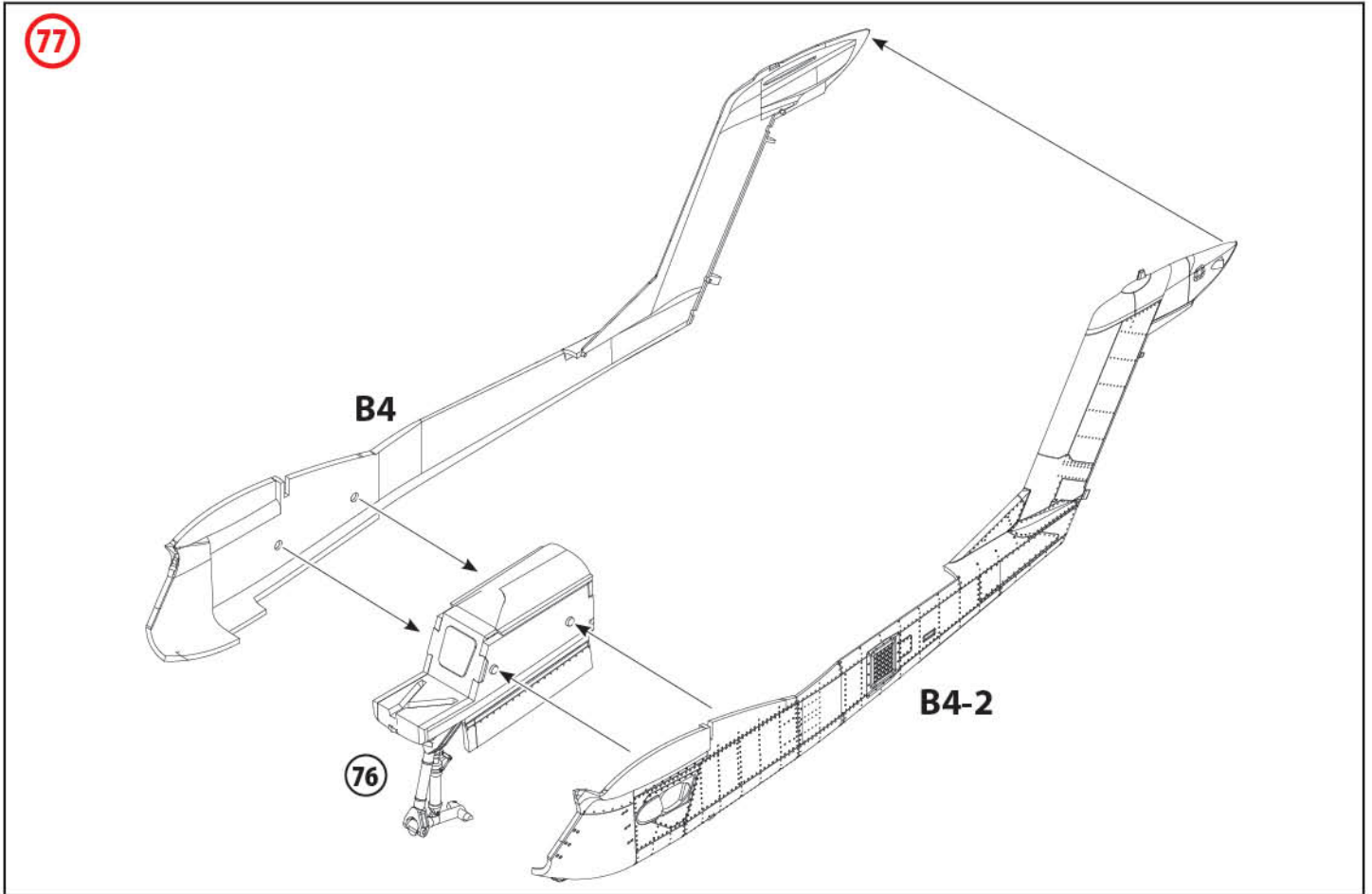
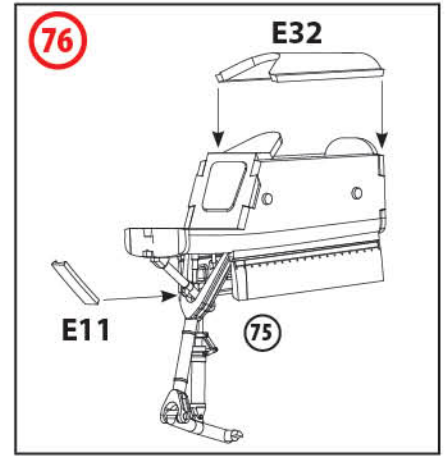
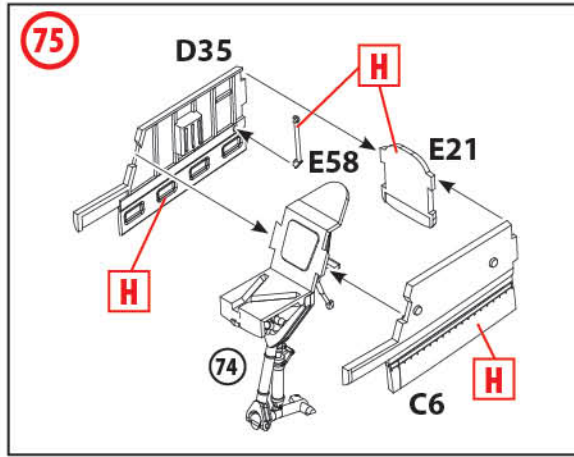
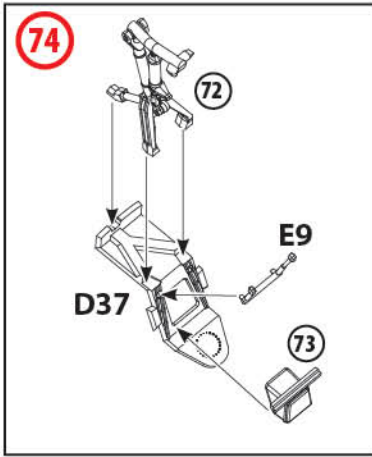

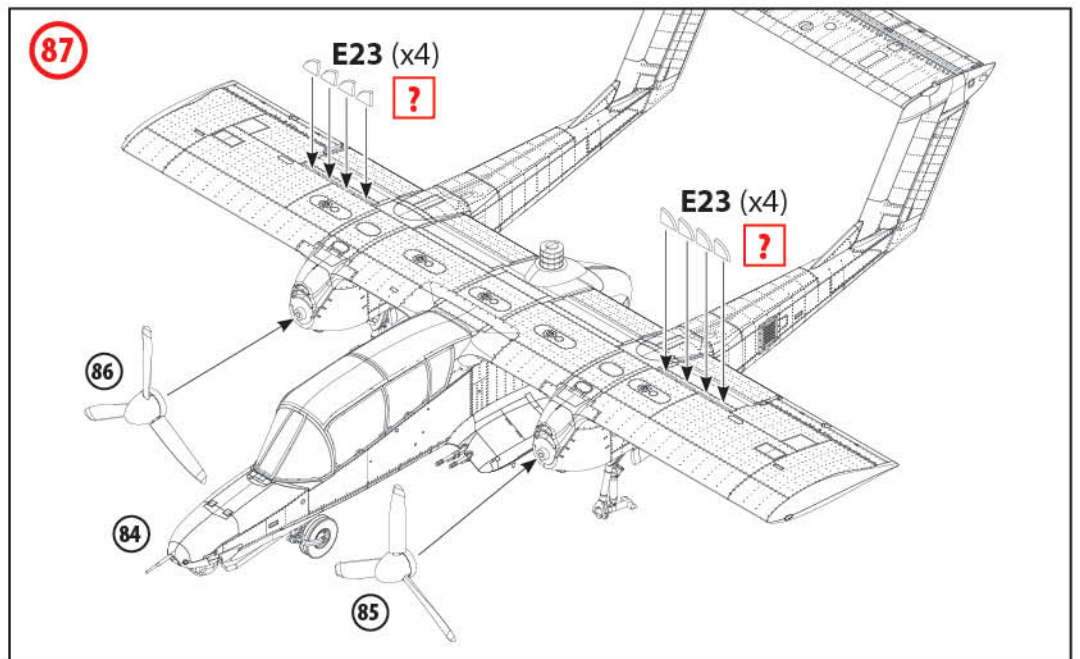
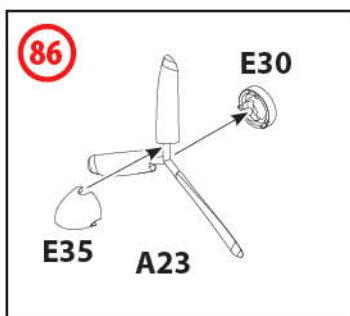
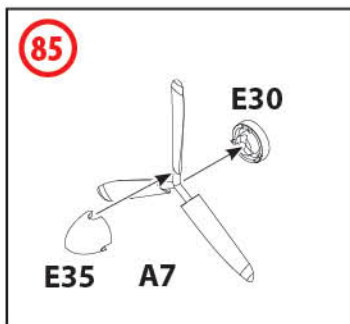
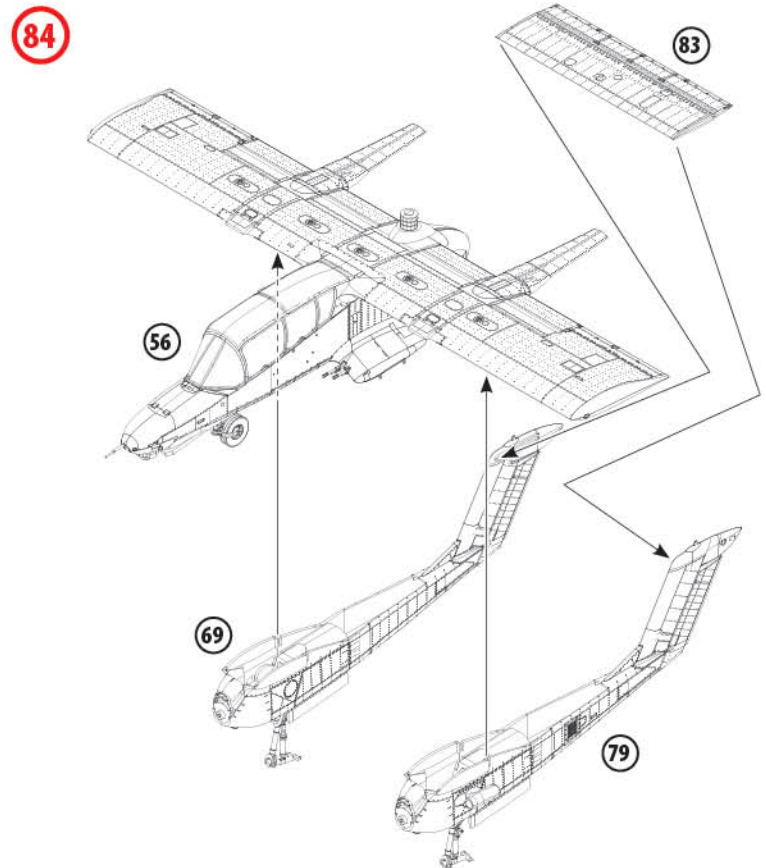
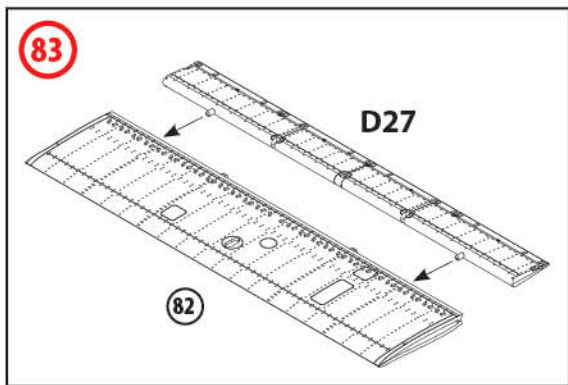
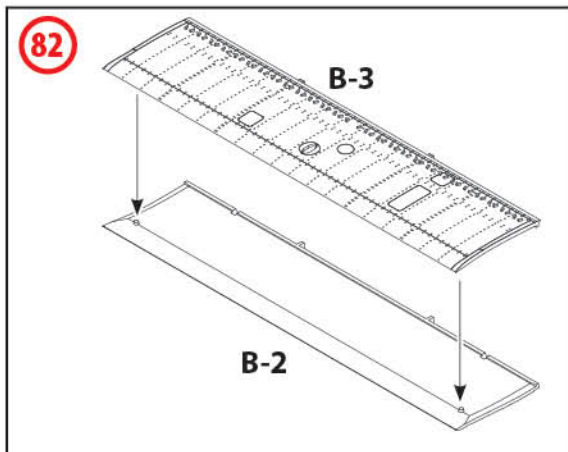
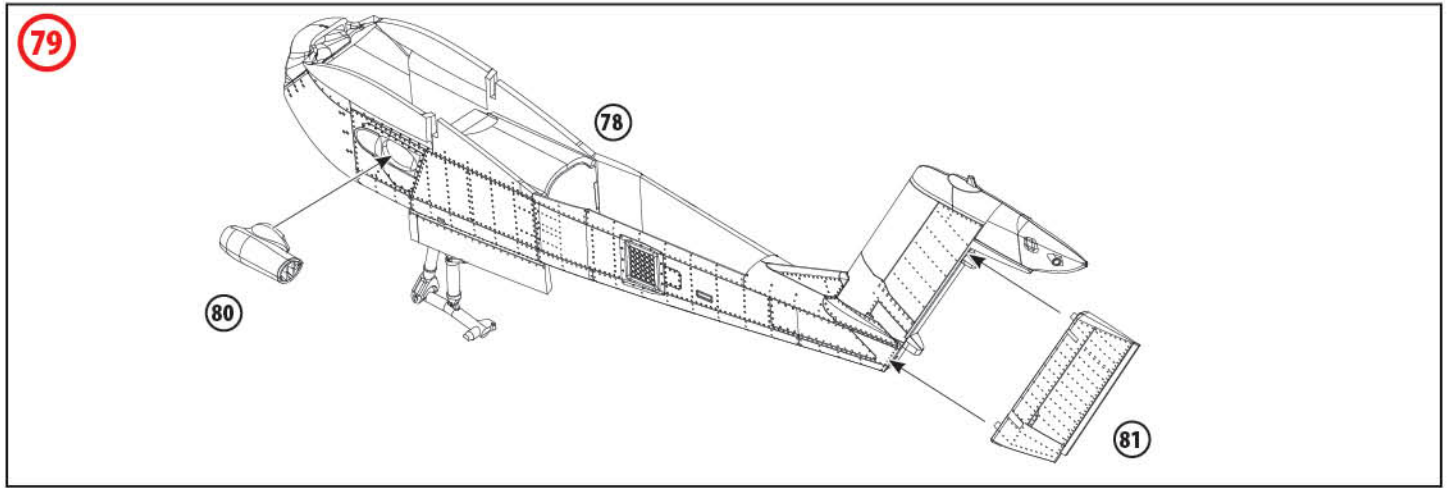

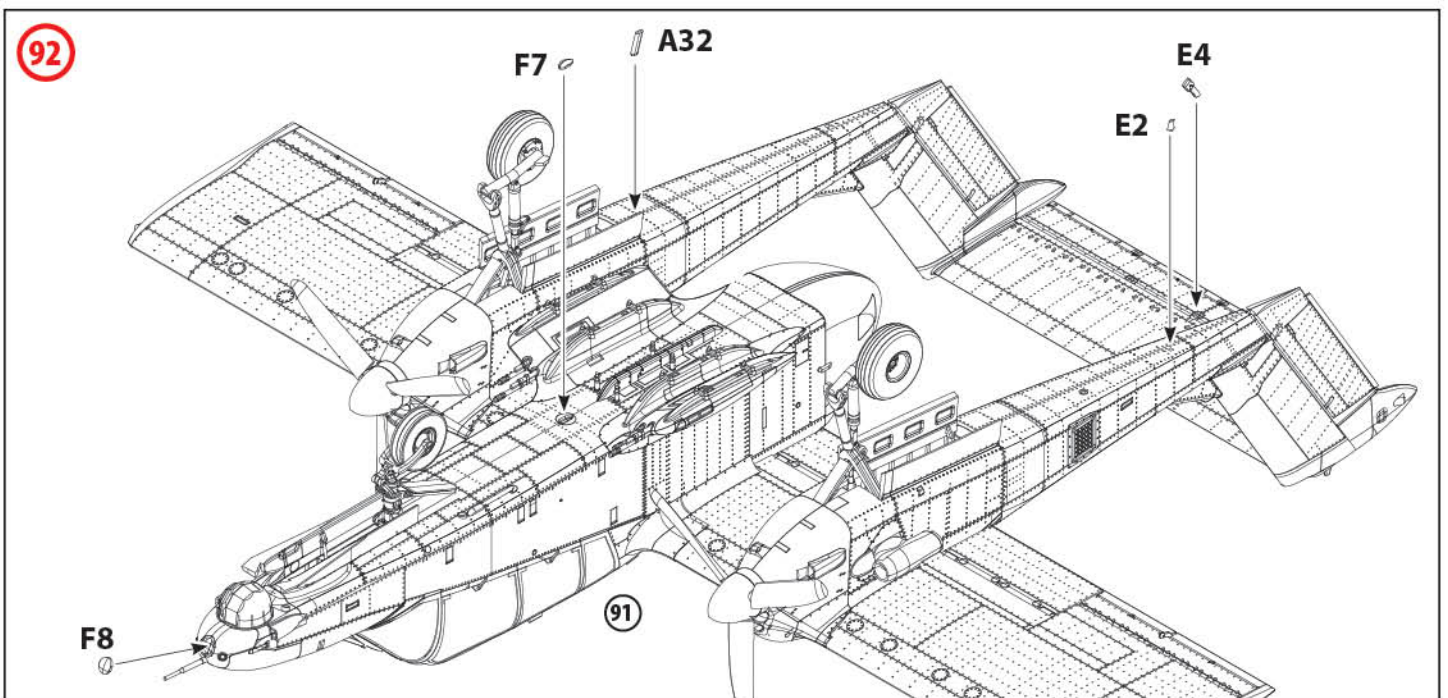
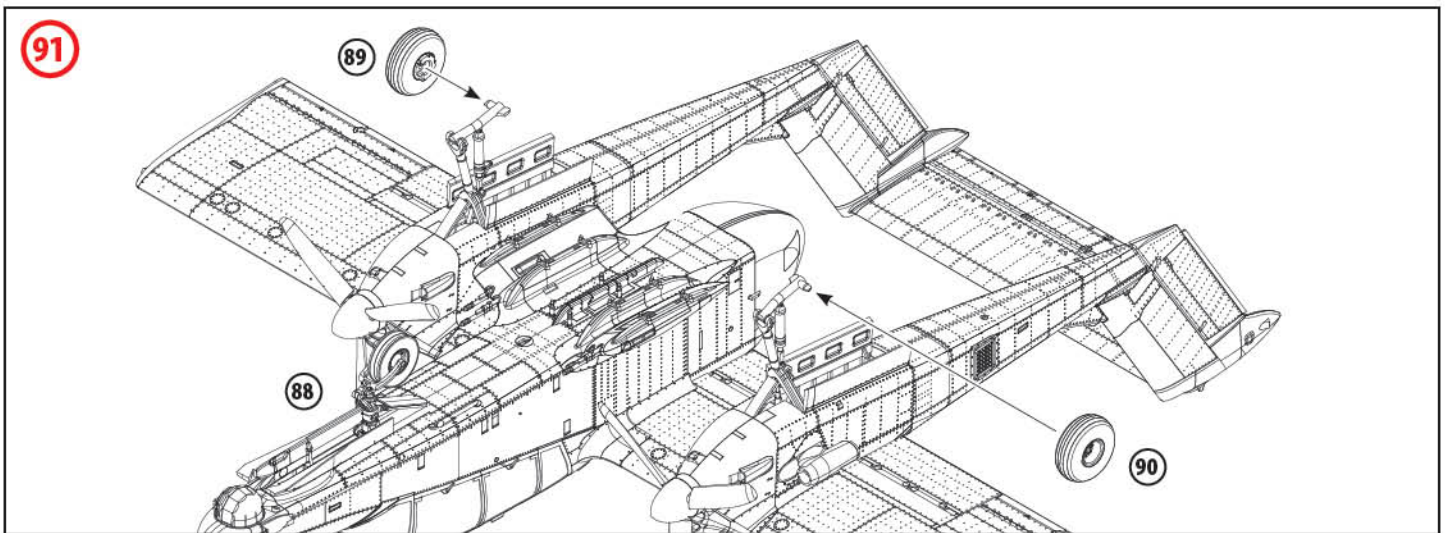
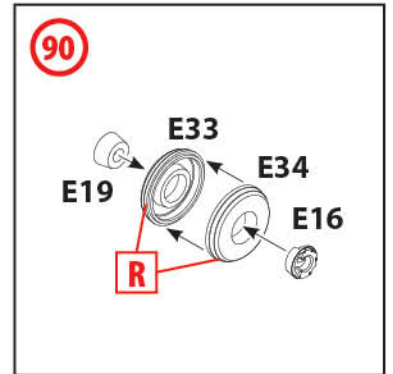
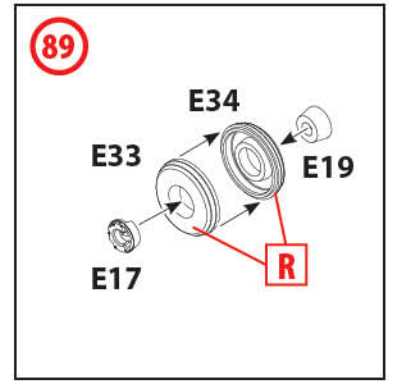
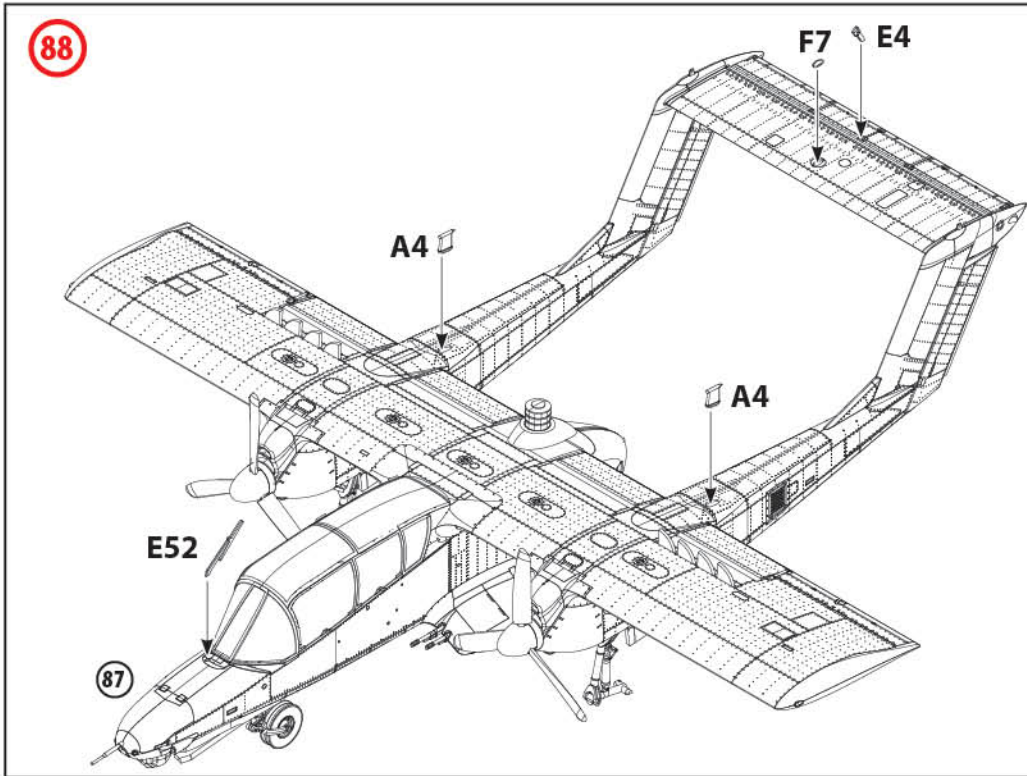

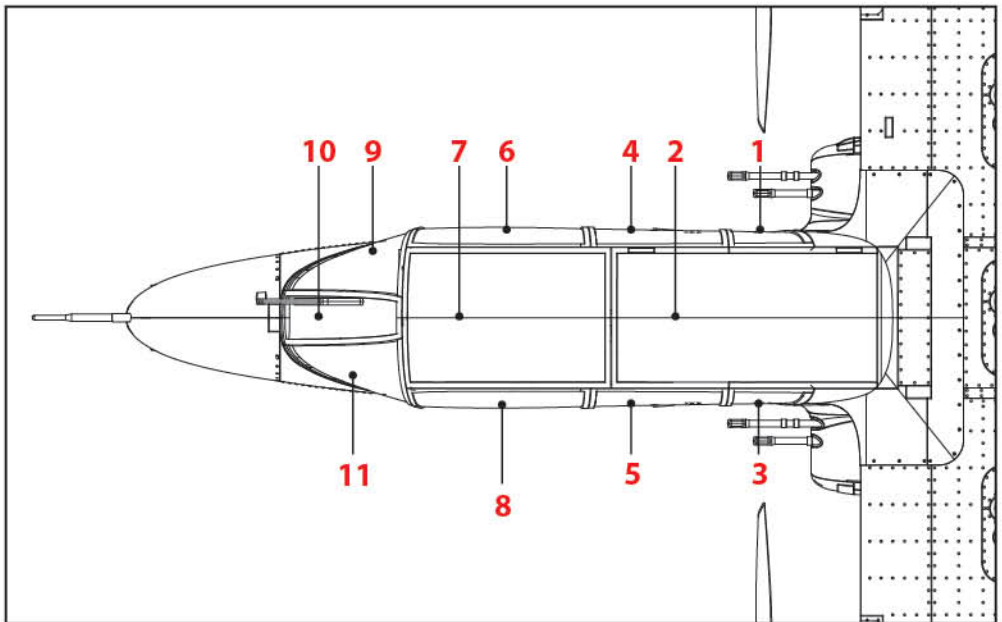
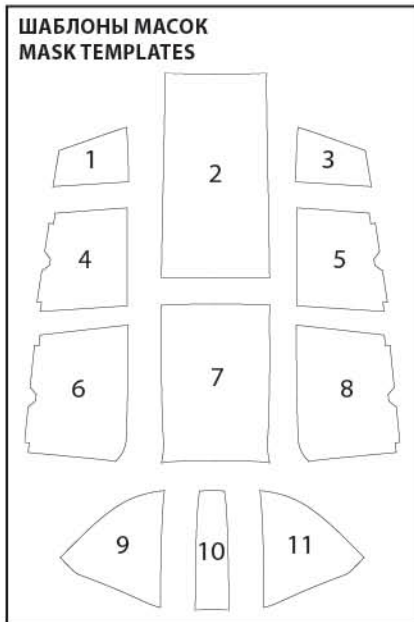
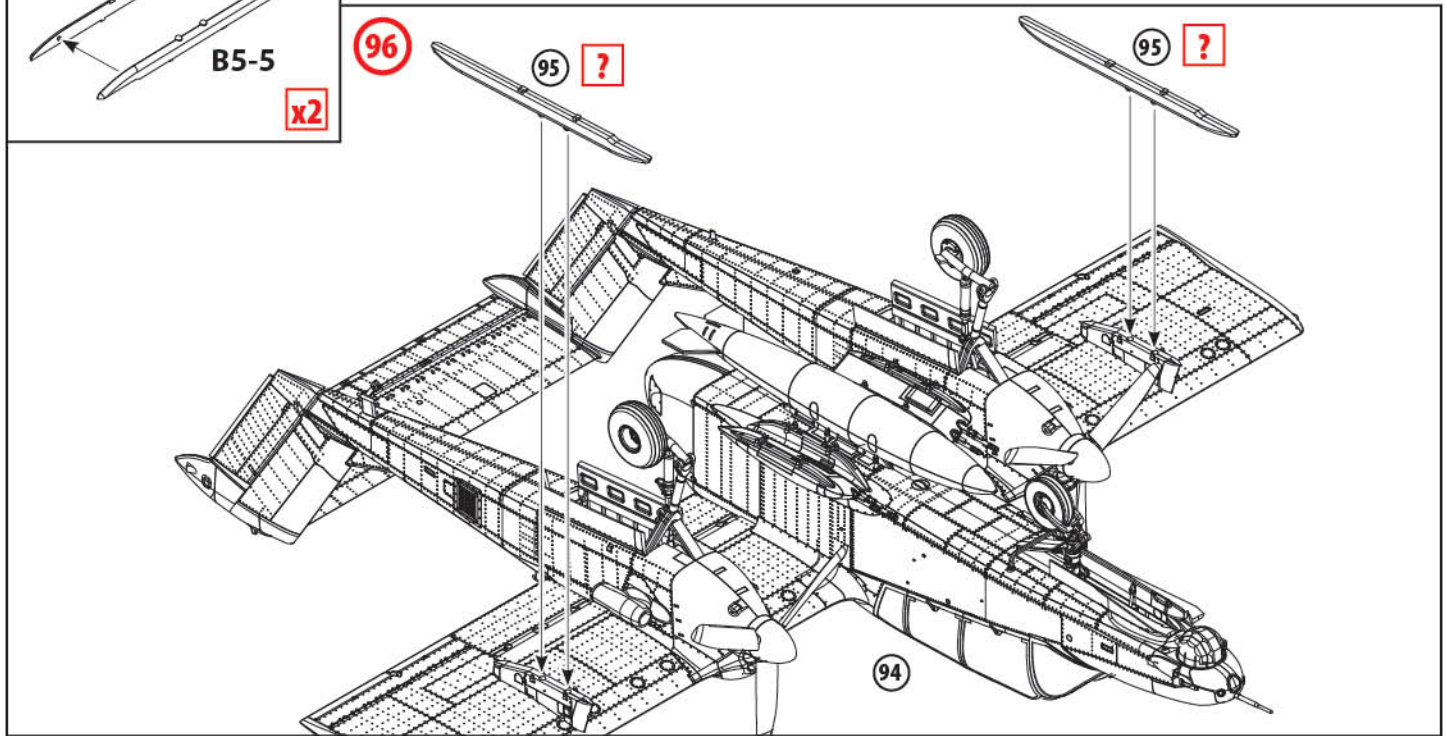
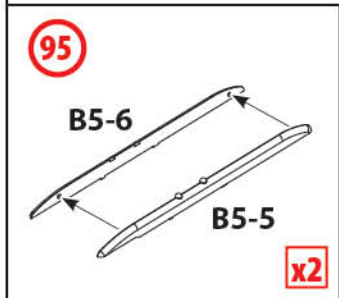
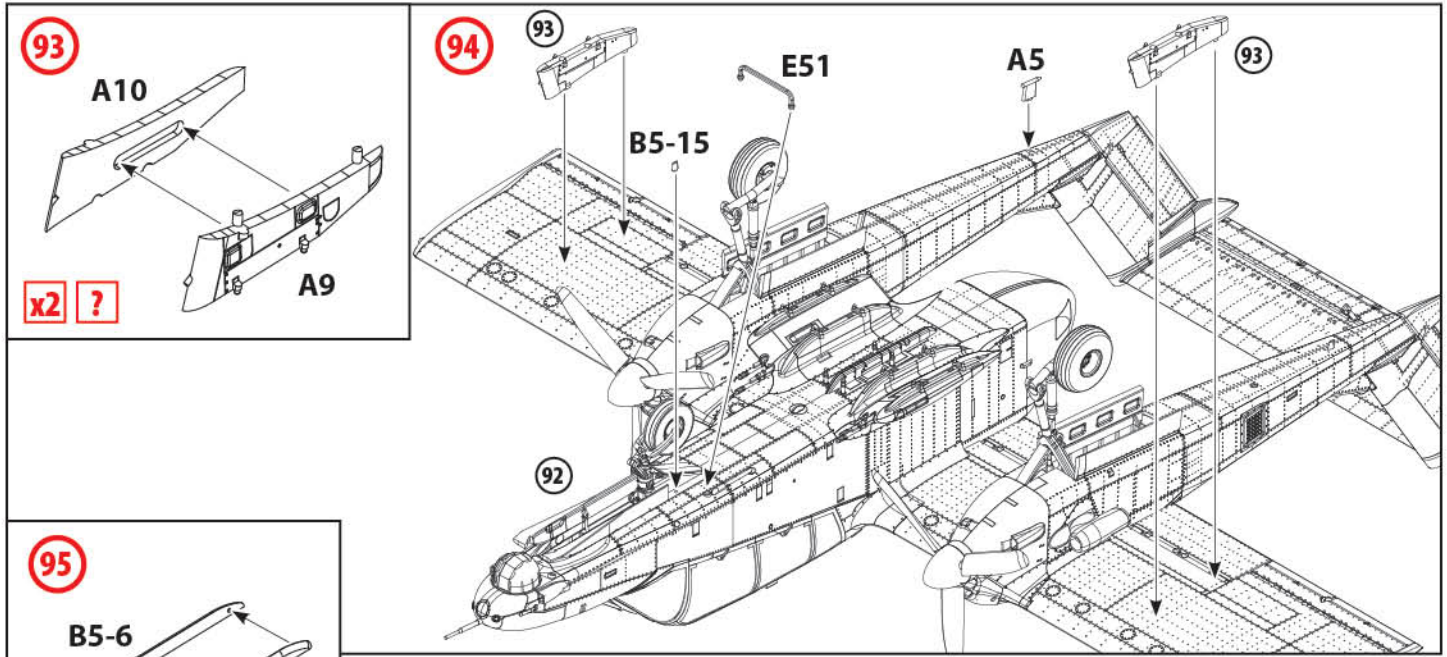

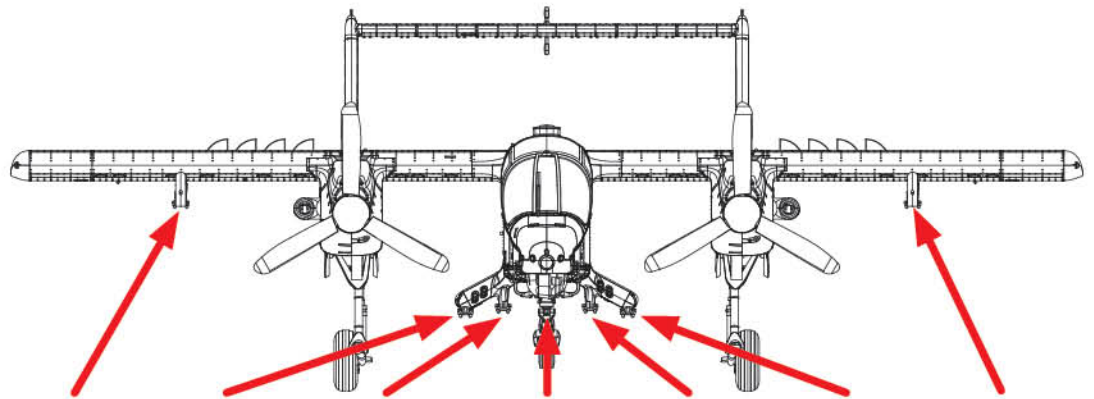
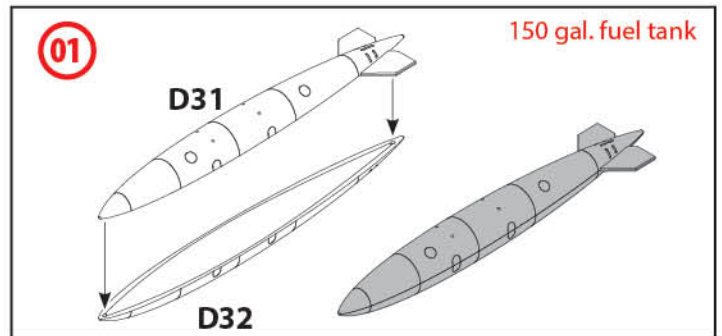
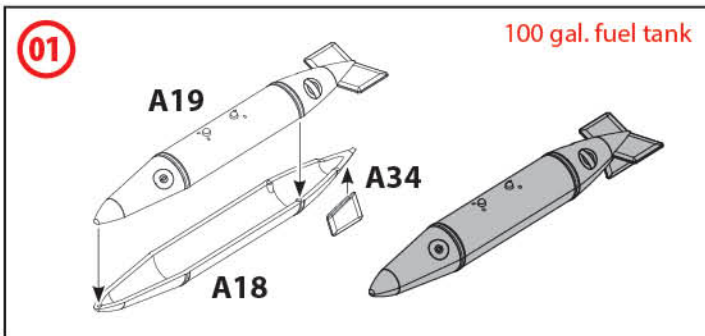
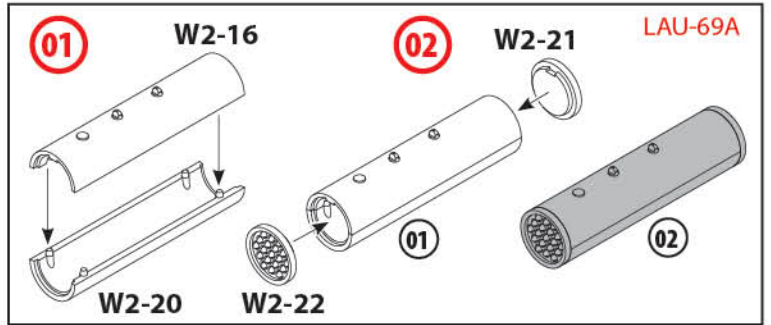
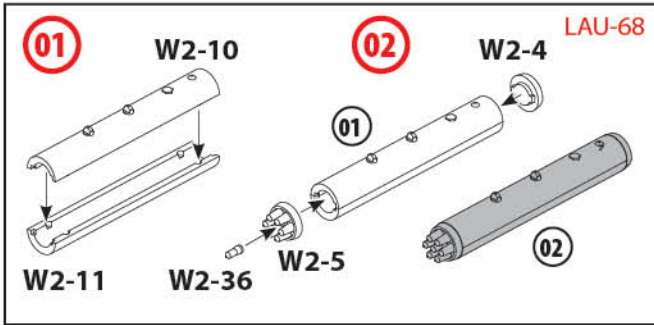
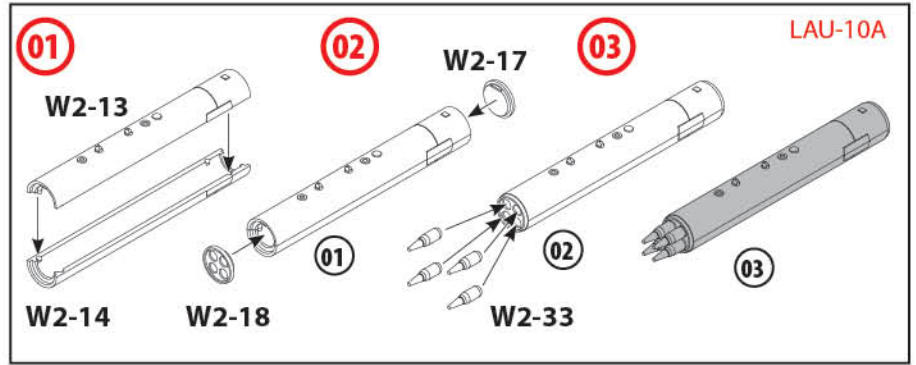
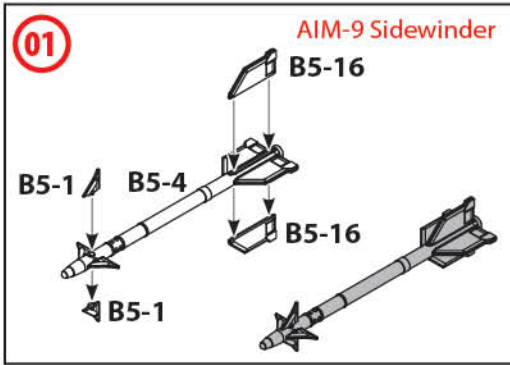

### OV-10A BRONCO

ДЛЯ ВАРІАНТІВ МАРКУВАННЯ 1,2 FOR MARKING OPTION 1,2	AIM-9 Sidewinder	-	-	150 gal. fuel tank	-	-	-
ДЛЯ ВАРІАНТІВ МАРКУВАННЯ 1,2 FOR MARKING OPTION 1,2	-	LAU-10	-	150 gal. fuel tank	-	LAU-68	AIM-9 Sidewinder
ДЛЯ ВАРІАНТІВ МАРКУВАННЯ 1,2 FOR MARKING OPTION 1,2	-	LAU-10	-	150 gal. fuel tank	-	LAU-10	-

### OV-10D+ BRONCO

ДЛЯ ВАРІАНТІВ МАРКУВАННЯ 3,4 FOR MARKING OPTION 3,4	100 gal. fuel tank	LAU-68	-	150 gal. fuel tank	-	LAU-10	100 gal. fuel tank
ДЛЯ ВАРІАНТІВ МАРКУВАННЯ 3,4 FOR MARKING OPTION 3,4	-	LAU-10	-	150 gal. fuel tank	-	LAU-10	-
ДЛЯ ВАРІАНТІВ МАРКУВАННЯ 3,4 FOR MARKING OPTION 3,4	LAU-69A	LAU-68	-	150 gal. fuel tank	-	LAU-68	LAU-69A
ДЛЯ ВАРІАНТІВ МАРКУВАННЯ 3,4 FOR MARKING OPTION 3,4	-	LAU-10	-	150 gal. fuel tank	-	LAU-10	AIM-9 Sidewinder



**ВАРІАНТ МАРКУВАННЯ 1  
MARKING OPTION 1**

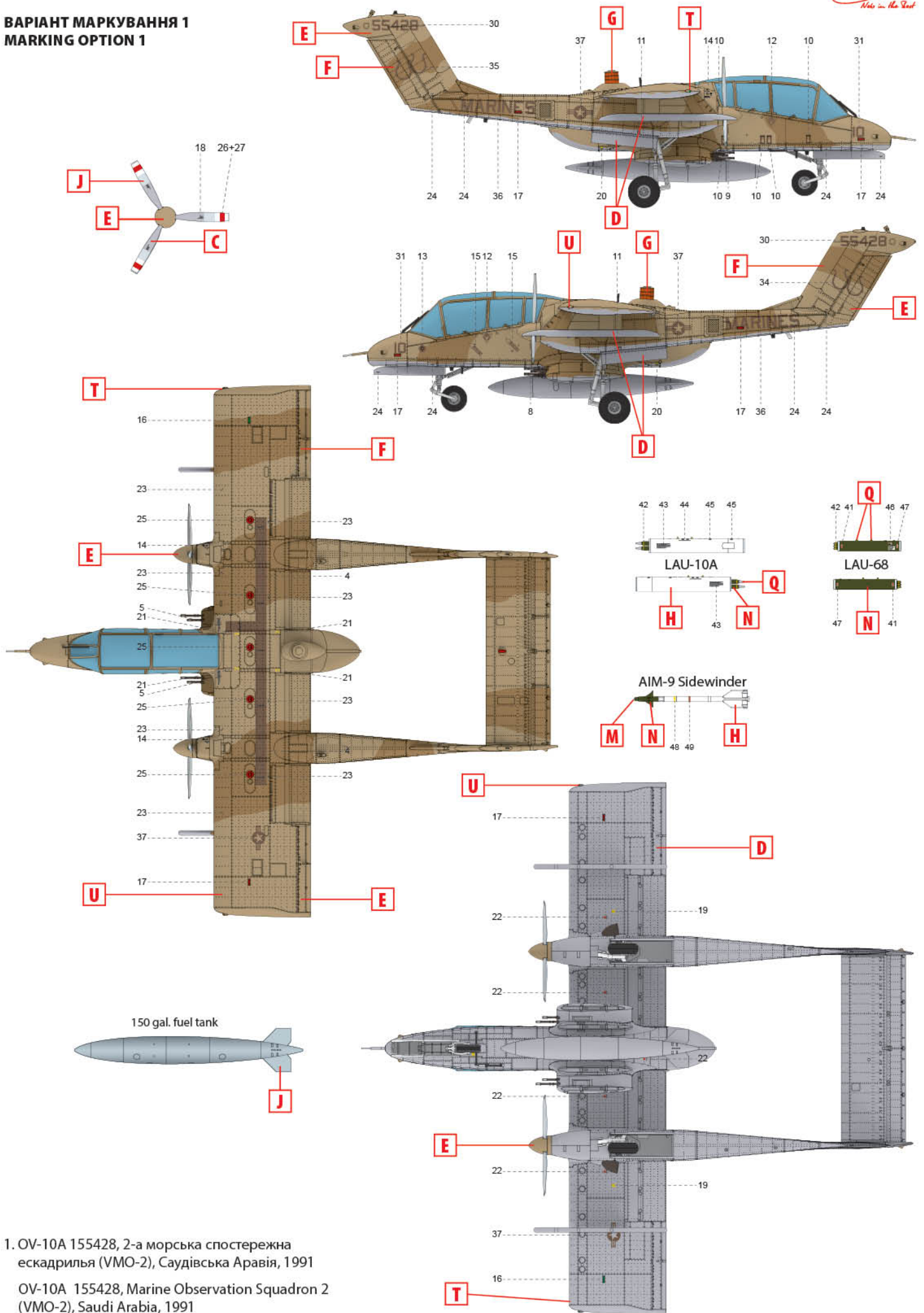

1. OV-10A 155428, 2-а морська спостережна ескадрилья (VMO-2), Саудівська Аравія, 1991  
 OV-10A 155428, Marine Observation Squadron 2 (VMO-2), Saudi Arabia, 1991

**ВАРІАНТ МАРКУВАННЯ 2**  
**MARKING OPTION 2**

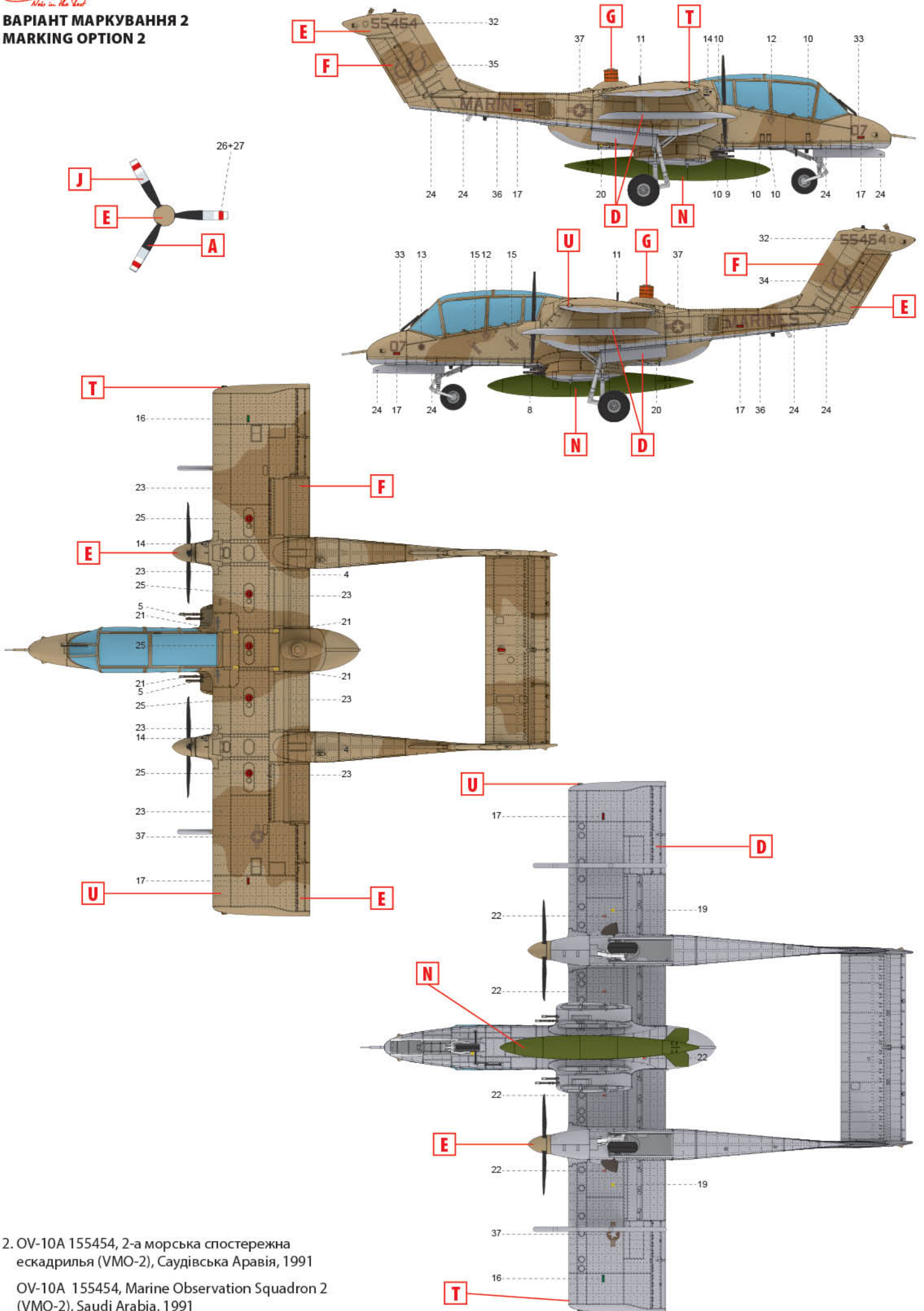

2. OV-10A 155454, 2-а морська спостережна ескадрилья (VMO-2), Саудівська Аравія, 1991

OV-10A 155454, Marine Observation Squadron 2 (VMO-2), Saudi Arabia, 1991

**ВАРІАНТ МАРКУВАННЯ 3  
MARKING OPTION 3**

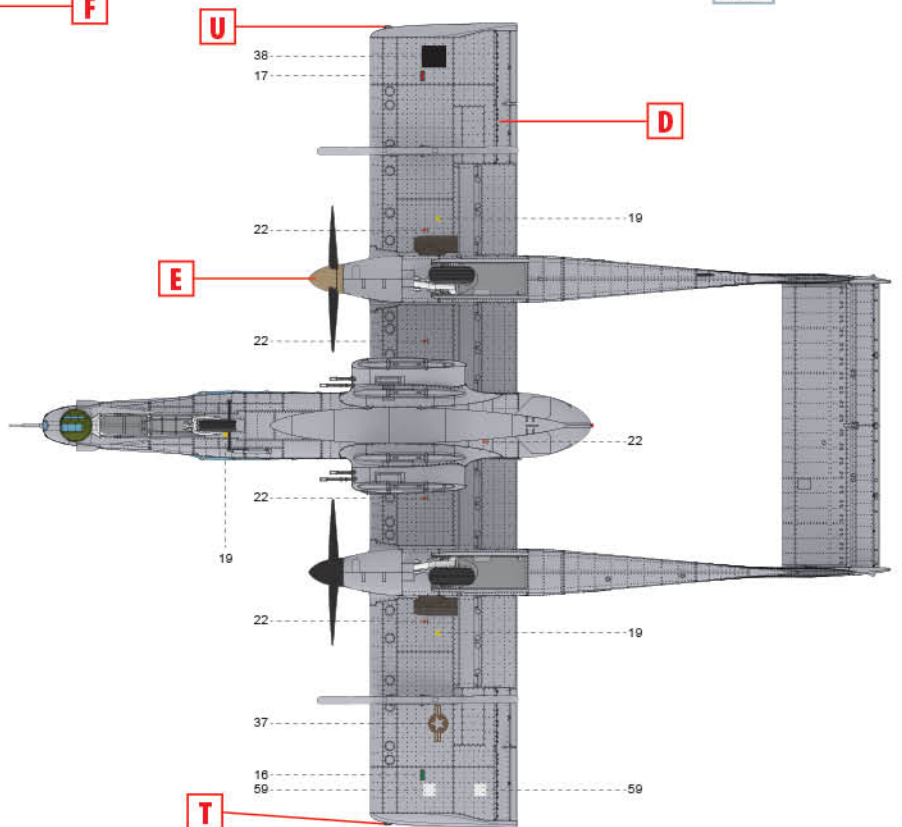
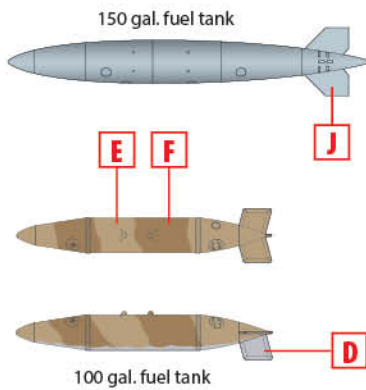
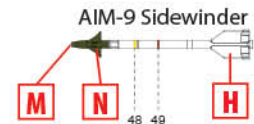
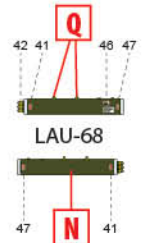
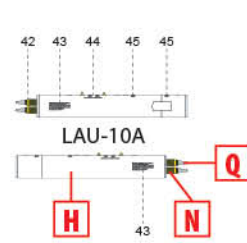
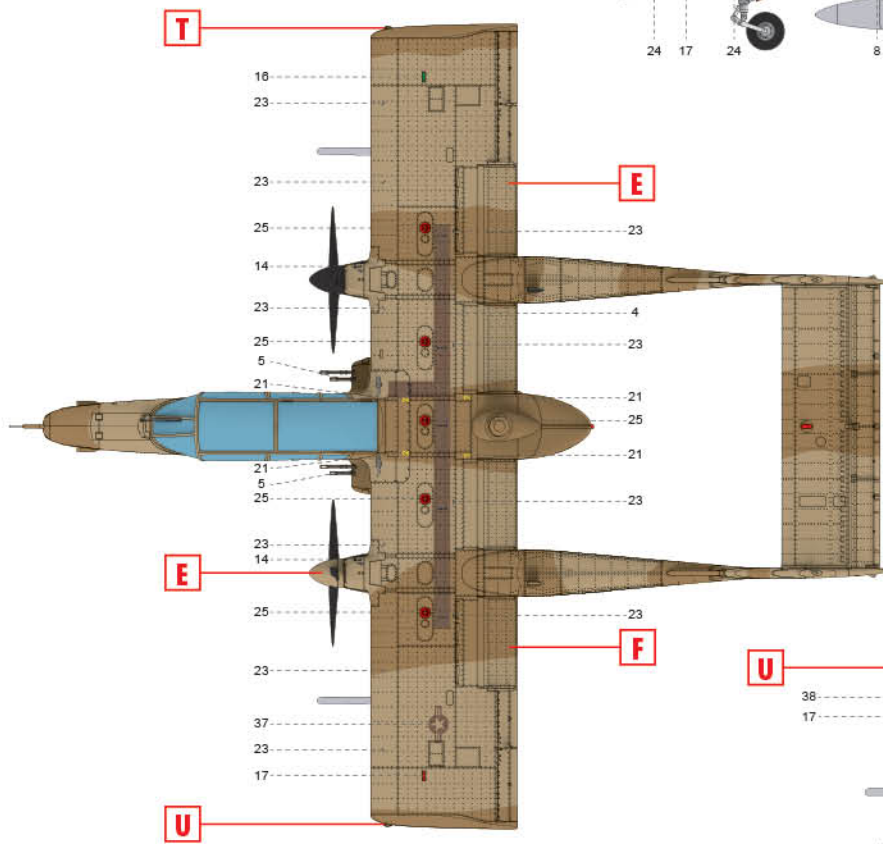
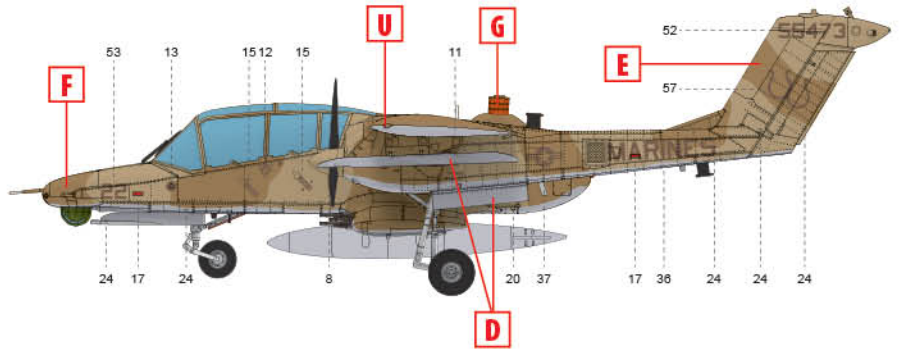
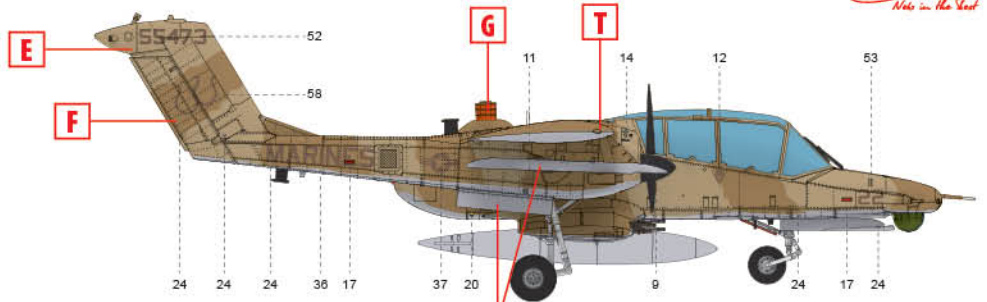
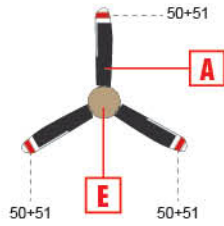

3. OV-10D+ 155473, 2-а морська спостережна ескадрилья (VMO-2), Саудівська Аравія, 1991

OV-10D+ 155473, Marine Observation Squadron 2 (VMO-2), Saudi Arabia, 1991

**ВАРІАНТ МАРКУВАННЯ 4**  
**MARKING OPTION 4**

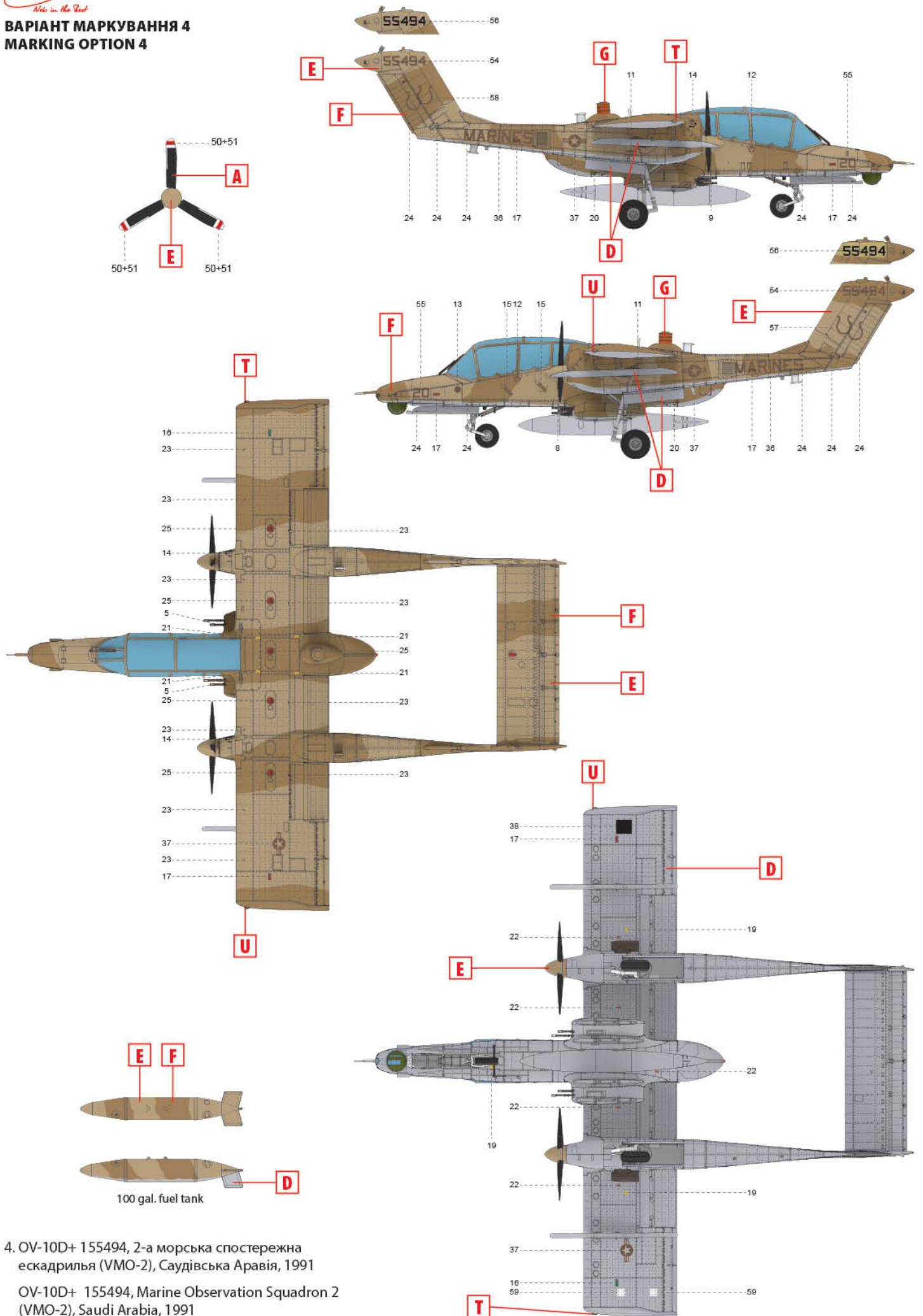

4. OV-10D+ 155494, 2-а морська спостережна ескадрилья (VMO-2), Саудівська Аравія, 1991

OV-10D+ 155494, Marine Observation Squadron 2 (VMO-2), Saudi Arabia, 1991